

harman/kardon

# hk3370/hk3470 STEREO RECEIVER

## SERVICE MANUAL



### CONTENTS

ESD WARNING.....	2	EXPLODED VIEW HK3370.....	25
LEAKAGE TESTING.....	3	EXPLODED VIEW HK3470.....	26
BASIC SPECIFICATIONS hk3370.....	4	DISASSEMBLY PROCEDURES.....	27
BASIC SPECIFICATIONS hk3470.....	5	MECHANICAL PARTS LIST HK3370.....	35
FRONT PANEL CONTROLS hk3370.....	6	ELECTRICAL PARTS LIST HK3370.....	36
REAR PANEL CONNECTIONS hk3370.....	8	MECHANICAL PARTS LIST HK3470.....	53
REMOTE CONTROL FUNCTIONS HK3370...10		ELECTRICAL PARTS LIST HK3470.....	54
FRONT PANEL CONTROLS hk3470.....	12	SEMICONDUCTOR PINOUTS .....	71
REAR PANEL CONNECTIONS hk3470.....	15	PCB DRAWINGS.....	104
REMOTE CONTROL FUNCTIONS HK3470...17		SCHEMATICS.....	110
BASIC TROUBLESHOOTING/RESET.....	19	WIRING DIAGRAM.....	121
TECH TIP HKTT2003-01.....	20	Hk3370 PACKAGE.....	122
ALIGNMENT PROCEDURES.....	21	Hk3470 PACKAGE.....	123
BLOCK DIAGRAM.....	24		

harman/kardon, Inc.  
250 Crossways Park Dr.  
Woodbury, New York 11797

Rev4 7/2005

## ELECTROSTATICALLY SENSITIVE (ES) DEVICES

Some semiconductor (solid state) devices can be damaged easily by static electricity. Such components commonly are called Electrostatically Sensitive (ES) Devices. Examples of typical ES devices are integrated circuits and some field effect transistors and semiconductor "chip" components.

The following techniques should be used to help reduce the incidence of component damage caused by static electricity.



1. Immediately before handling any semiconductor component or semiconductor-equipped assembly, drain off any electrostatic charge on your body by touching a known earth ground. Alternatively, obtain and wear a commercially available discharging wrist strap device, which should be removed for potential shock reasons prior to applying power to the unit under test.
2. After removing an electrical assembly equipped with ES devices, place the assembly on a conductive surface such as aluminum foil, to prevent electrostatic charge build-up or exposure of the assembly.
3. Use only a grounded-tip soldering iron to solder or unsolder ES devices.
4. Use only an anti-static solder removal device. Some solder removal devices not classified as "anti-static" can generate electrical charges sufficient to damage ES devices.
5. Do not use freon-propelled chemicals. These can generate electrical charge sufficient to damage ES devices.
6. Do not remove a replacement ES device from its protective package until immediately before you are ready to install it. (Most replacement ES devices are packaged with leads electrically shorted together by conductive foam, aluminum foil or comparable conductive material.)
7. Immediately before removing the protective material from the leads of a replacement ES device, touch the protective material to the chassis or circuit assembly into which the device will be installed.

**CAUTION** : Be sure no power is applied to the chassis or circuit, and observe all other safety precautions.

8. Minimize bodily motions when handling unpackaged replacement ES devices. (Otherwise harmless motion such as the brushing together of your clothes fabric or the lifting of your foot from a carpeted floor can generate static electricity sufficient to damage an ES devices.

## PRODUCT SAFETY NOTICE

Each precaution in this manual should be followed during servicing.

Components identified with the IEC symbol  in the parts list are special significance to safety. When replacing a component identified with , use only the replacement parts designated, or parts with the same ratings or resistance, wattage, or voltage that are designated in the parts list in this manual. Leakage-current or resistance measurements must be made to determine that exposed parts are acceptably insulated from the supply circuit before returning the product to the customer.

## LEAKAGE TEST(FOR SERVICE ENGINEERS IN THE U.S.A)

Before returning the unit to the user, perform the following safety checks :

1. Inspect all lead dress to make certain that leads are not pinched or that hardware is not lodged between the chassis and other metal parts in the unit.

2. Be sure that any protective devices such as nonmetallic control knobs, insulating fish-papers, cabinet backs, adjustment and compartment covers or shields, isolation resistor-capacity networks, mechanical insulators, etc. Which were removed for the servicing are properly re-installed.

3. Be sure that no shock hazard exists ; check for leakage current using Simpson Model 229 Leakage Tester, standard equipment item No. 21641, RCA Model WT540A or use alternate method as follows : Plug the power cord directly into a 120 volt AC receptacle (do not use an Isolation Transformer for this test). Using two clip leads, connect a

1500 ohms, 10watt Resistor paralleled by a 0.15uF capacitor, in series with all exposed metal cabinet parts and a known earth ground, such as a water pipe or conduit. Use a VTVM or VOM with 1000 ohms per volt, or higher sensitivity to measure the AC voltage drop across the resistor. (See diagram) Move the resistor connection to each exposed metal part having a return path to the chassis (antenna, metal, cabinet, screw heads, knobs and control shafts, escutcheon, etc.) and measure the AC voltage drop across the resistor. (This test should be performed with the 0.35 volt RMS or more is excessive and indicates a potential shock hazard which must be corrected before returning the unit to the owner.

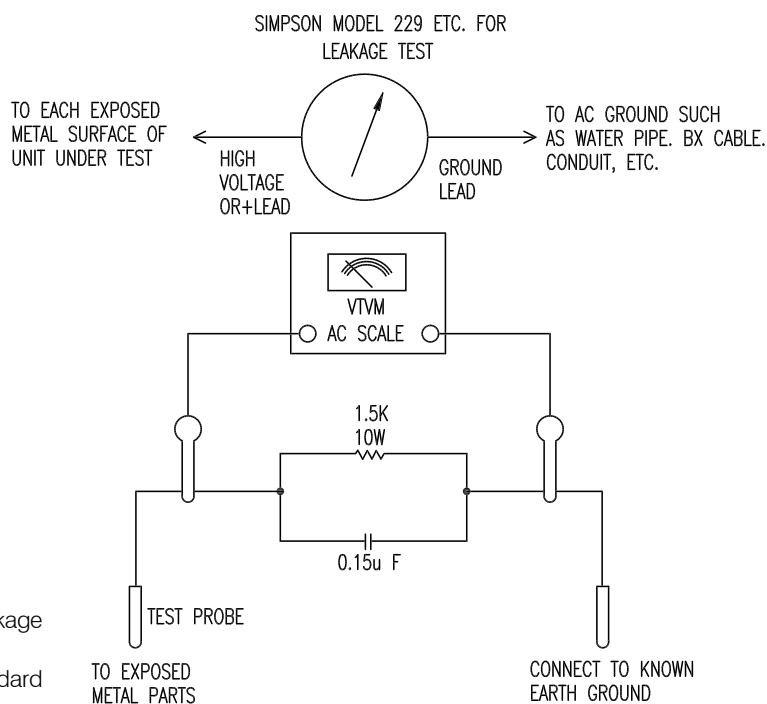

## Technical Specifications

### Audio Section

Stereo Mode

Continuous Average Power (FTC)

70 Watts per channel, 20Hz–20kHz

@ < 0.07% THD, both channels driven into 8 ohms

95 Watts per channel, 20Hz–20kHz

@ < 0.2% THD, both channels driven into 4 ohms

Input Sensitivity/Impedance

Linear (High Level) 200mV/47kohms

Signal-to-Noise Ratio (IHF-A) 95dB

Frequency Response

@ 1W (+0dB, -3dB) 10Hz–110kHz

High Instantaneous

Current Capability (HCC) ±42 Amps

Transient Intermodulation

Distortion (TIM) Unmeasurable

Rise Time 16 µsec

Slew Rate 40V/µsec

Depth measurement includes knobs, buttons and terminal connections.

Height measurement includes feet and chassis.

All features and specifications are subject to change without notice.

Harman Kardon is a registered trademark, and Power for the digital revolution is a trademark, of Harman Kardon, Inc.

### FM Tuner Section

Frequency Range 87.5–108MHz

Usable Sensitivity IHF 1.12 µV/13.5dBf

Signal-to-Noise Ratio Mono/Stereo 73/72dB

Distortion Mono/Stereo 0.3/0.4%

Stereo Separation 40dB @ 1kHz

Selectivity ±400kHz, 65dB

Image Rejection >80dB

IF Rejection >100dB

Tuner Output Level 1kHz, ±100kHz Dev 500mV

### AM Tuner Section

Frequency Range 520–1710kHz

Signal-to-Noise Ratio >40dB

Usable Sensitivity Loop 500µV/M

Distortion 1kHz, 50% Mod 0.8%

Selectivity ±10kHz, >25dB

### General

Power Requirement AC 120V/60Hz

Power Consumption 72W idle, 332W maximum  
(both channels driven)

### Dimension (Max)

Width 17.4 inches (442mm)

Height 6.1 inches (156mm)

Depth 16.3 inches (415mm)

Weight 24.6 lb (11.2kg)

**H** A Harman International Company

250 Crossways Park Drive, Woodbury, New York 11797

www.harmankardon.com

© 2000 Harman Kardon, Incorporated

Part #YIAR-K1001-02A

**harman/kardon**

## hk3470

## Technical Specifications

### Audio Section

Stereo Mode	
Continuous Average Power (FTC)	
100 Watts per channel, 20Hz–20kHz	@ < 0.07% THD, both channels driven into 8 ohms
135 Watts per channel, 20Hz–20kHz	@ < 0.2% THD, both channels driven into 4 ohms
Input Sensitivity/Impedance	
Linear (High Level)	200mV/47kohms
Signal-to-Noise Ratio (IHF-A)	95dB
Frequency Response	
@ 1W (+0dB, -3dB)	10Hz–110kHz
High Instantaneous Current Capability (HCC)	
	±45 Amps
Transient Intermodulation Distortion (TIM)	
	Unmeasurable
Rise Time	16 μsec
Slew Rate	40V/μsec

### FM Tuner Section

Frequency Range	87.5–108MHz
Usable Sensitivity	IHF 1.12 μV/13.5dBf
Signal-to-Noise Ratio	Mono/Stereo 73/72dB
Distortion	Mono/Stereo 0.3/0.4%
Stereo Separation	40dB @ 1kHz
Selectivity	±400kHz, 65dB
Image Rejection	>80dB
IF Rejection	>100dB
Tuner Output Level	1kHz, ±100kHz Dev 500mV

### AM Tuner Section

Frequency Range	520–1710kHz
Signal-to-Noise Ratio	>40dB
Usable Sensitivity	Loop 500μV/M
Distortion	1kHz, 50% Mod 0.8%
Selectivity	±10kHz, >25dB

### General

Power Requirement	AC 120V/60Hz
Power Consumption	72W idle, 332W maximum (both channels driven)

### Dimension (Max)

Width	17.4 inches (442mm)
Height	6.1 inches (156mm)
Depth	16.3 inches (415mm)
Weight	26.8 lb (12.1kg)

Depth measurement includes knobs, buttons and terminal connections. Height measurement includes feet and chassis.

All features and specifications are subject to change without notice.

Harman Kardon is a registered trademark, and Power for the digital revolution is a trademark, of Harman Kardon, Inc.

VMAx is a registered trademark of Harman International Industries, Inc., and is an implementation of Cooper Bauck Transaural Stereo under patent license.



## Front Panel Controls

**8 Phono Input Selector:** Press this button to select the output of a turntable that is connected to the **Phono** inputs **6**.

**9 T-Mon Input Selector:** Press this button to listen to the output of a tape recorder connected to the **Tape Monitor** inputs **9**. The T-Mon indicator will illuminate to indicate that the input source is being monitored when the HK 3370 is connected to a three-head tape deck or another unit with off-head playback.

**10 Tuning Button:** Press the left side of the button to tune lower frequency stations and the right side of the button to tune higher frequency stations. When a station with a strong signal is tuned, the **TUNED** indicator will illuminate in the **Information Display 25**. A brief (1/2 second) press of the button will manually tune to the next frequency increment, while pressing and holding the button for a longer period will automatically tune to the next station with a signal strong enough for acceptable reception.

**11 Tape Input Selector:** Press this button to listen to the output of a tape recorder or other device connected to the **Tape 2** inputs **11**.

**12 Preset Scan:** Press this button to automatically scan through the stations that have been programmed in the HK 3370's memory. The tuner will play five seconds of each station before moving to the next preset station. To stop the scan when the desired station is heard, press the button again. (See page 14 for more information on the tuner memory system.)

**13 CD Input Selector:** Press this button to listen to the output of a CD player connected to the **CD** inputs **7**.

**14 Aux Input Selector:** Press this button to listen to the output of a device connected to the **Aux** inputs **8**.

**15 Preset Selector:** Press this button to step up or down through the list of stations that has been entered into the preset memory. (See page 14 for more information on tuner programming.)

**16 Dimmer Button:** Press this button to dim the front panel displays and indicators. The first press of the button will dim the displays to one-half normal brightness; the next press will turn all displays off except for the **Power Indicator 3** and the **Speaker Selection Indicators 26**. Note that when the panel is dimmed, it will return to normal brightness after the unit is turned off, then on again.

**17 FM/AM Selector:** Press this button to select the tuner as the input to the receiver. When the tuner is in use, press this button to change between the AM and FM frequency bands.

**18 FM Mode Selector:** Press this button to select the stereo or mono mode for FM tuning. In the STEREO mode, a **Stereo** indicator will illuminate in the **Information Display 25**, and stereo reception will be provided when stations are transmitting stereo signals. In the MONO mode, the left and right signals from stereo broadcasts will be mixed together and reproduced through all channels. Select MONO for better reception of weak signals.

**19 Sleep Button:** Press this button to place the unit in the Sleep mode. Each press of the button selects the amount of time that will remain before the unit automatically goes into the Standby mode, as shown in the **Information Display 25**, in the following order:

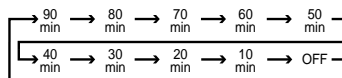

**20 Bass Control:** Turn this control to modify the low-frequency output of the left/right channels by as much as  $\pm 10$ dB. Set this control to a suitable position for your taste and room acoustics.

**21 Treble Control:** Turn this control to modify the high-frequency output of the left/right channels by as much as  $\pm 10$ dB. Set this control to a suitable position for your taste and room acoustics.

**22 Balance Control:** Turn this control to change the relative volume for the front left/right channels.

**23 Volume Control:** Turn the knob clockwise to increase volume, counterclockwise to decrease the volume.

**24 Volume/Mute Indicator:** This indicator will glow green when the HK 3370 is turned on. Its position will enable you to judge the relative volume of the unit even when the speakers are muted or turned off. When the indicator is pointing toward the left, at an "8 o'clock" position, the volume is low; when it is pointing to the right, as in a "3 o'clock" position, the volume is loud. When the unit has been muted by pressing the **Mute** button **5** **R**, the indicator will flash.

**25 Information Display:** This display delivers messages and status indications to help you operate the receiver.

**26 Speaker Selection Indicators:** These indicators light as a green LED next to the designation for each speaker pair to show when they are active. Press the **Speaker 1 7** or **Speaker 2 7** **Selectors** to activate either pair of speakers.

**27 Remote Sensor Window:** The sensor behind this window receives infrared signals from the remote control. Aim the remote at this area and do not block or cover it unless an external remote sensor is installed.

# Rear Panel Connections

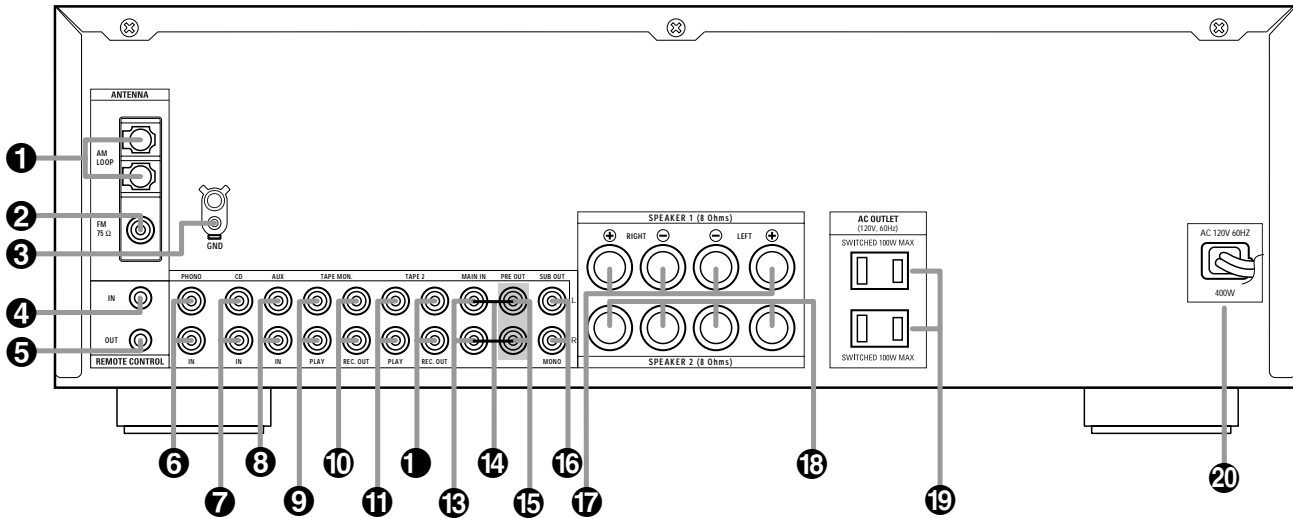

- 1 AM Antenna
- 2 FM Antenna
- 3 Phono Ground
- 4 Remote IR In
- 5 Remote IR Out
- 6 Phono Inputs
- 7 CD Inputs

- 8 Aux Inputs
- 9 Tape Monitor Play/In
- 10 Tape Monitor Record/Out
- 11 Tape 2 Play/In
- 12 Tape 2 Record/Out
- 13 Main In
- 14 Pre-Out/Main-In Jumper Pins

- 15 Preamp Out
- 16 Subwoofer Out
- 17 Speaker 1 Terminals
- 18 Speaker 2 Terminals
- 19 Accessory Outlets
- 20 Power Cable



## Rear Panel Connections

**1 AM Antenna:** Connect the AM loop antenna supplied with the receiver to these terminals. If an external AM antenna is used, make connections to the **AM** and **GND** terminals in accordance with the instructions supplied with the antenna.

**2 FM Antenna:** Connect an indoor or external FM antenna to this terminal.

**3 Phono Ground:** Connect the ground wire from a turntable to this terminal to reduce system hum.

**4 Remote IR In:** If the HK 3370's front panel IR sensor is blocked due to cabinet doors or other obstructions, an external IR sensor may be used. Connect the output of the sensor to this jack.

**5 Remote IR Out:** This connection permits the IR sensor in the receiver to serve other remote controlled devices. Connect this jack to the "IR IN" jack on Harman Kardon or other compatible equipment.

**6 Phono Inputs:** Connect the outputs of your turntable or tone arm to these jacks. Note that only Moving Magnet (MM) type cartridges may be used.

**7 CD Inputs:** Connect these jacks to the output of a compact disc player or CD changer.

**8 Aux Inputs:** Connect these jacks to the line-level output of any audio device such as a TV, cable converter or portable audio player.

**9 Tape Monitor Play/In:** Connect these jacks to the Play/Out jacks of an audio recorder.

**10 Tape Monitor Record/Out:** Connect these jacks to the Rec/In jacks of an audio recorder.

NOTE: When these jacks are connected to a three-head recorder or another device with off-head playback, it will be possible to monitor the source being recorded.

**11 Tape 2 Play/In:** Connect these jacks to the PLAY/OUT jacks of a second audio recorder.

**1 Tape 2 Record/Out:** Connect these jacks to the Rec/In jacks of a second audio recorder.

**13 Main In:** These jacks are the input to the HK 3370's power amplifier. Unless an external power amplifier is used, the jumper pins should remain connected to the **Preamp Out** jacks **14**.

**14 Pre-Out/Main-In Jumper Pins:** These pins connect the receiver's preamp and amplifier sections. Unless an external amplifier, equalizer or speaker processor is used, they should be left connected. See page 12 for more information on external amplifier connections.

**15 Preamp Out:** These jacks provide an output for the left and right channels to an optional external amplifier. In normal operation, unless an external power amplifier is used, the jumper pins should remain connected to the **Main In** jacks **13**.

**16 Subwoofer Out:** Connect these jacks to the line level input of a powered subwoofer. If an external subwoofer amplifier is used, connect this jack to the subwoofer amplifier input. When a single, mono subwoofer is used, make the connection to the bottom jack.

**17 Speaker 1 Terminals:** Connect these terminals to the appropriate terminals on your speakers.

**18 Speaker 2 Terminals:** Connect these terminals to the appropriate terminals on your speakers.

**19 Accessory Outlets:** These outlets may be used to power low-current draw devices such as CD players or cassette decks. The power to these outlets remains on as long as the receiver itself is on. When the receiver is turned off, or placed in the Standby mode, power to these outlets is removed.

NOTE: The power consumption of the devices plugged into these outlets should not exceed 100 watts.

**20 Power Cable:** Connect the AC plug to a nonswitched AC wall output.

# Remote Control Functions

- A** Main Power On
- B** Main Power Off
- C** Source Selectors
- D** Preset Up/Down
- E** Transport Controls
- F** Disc Skip
- G** Sleep Button
- H** Dimmer Button
- I** Tuning
- J** Direct Button
- K** Numeric Keys
- L** Auto Preset
- M** Secondary Control Cover
- N** Clear Button
- O** Memory Button
- P** Master Volume
- Q** P. Scan Button
- R** Mute Button
- S** FM Mode Button
- T** Tuning Up/Down
- U** Speaker 1 Selector
- V** Speaker 2 Selector
- W** Transmitter Window

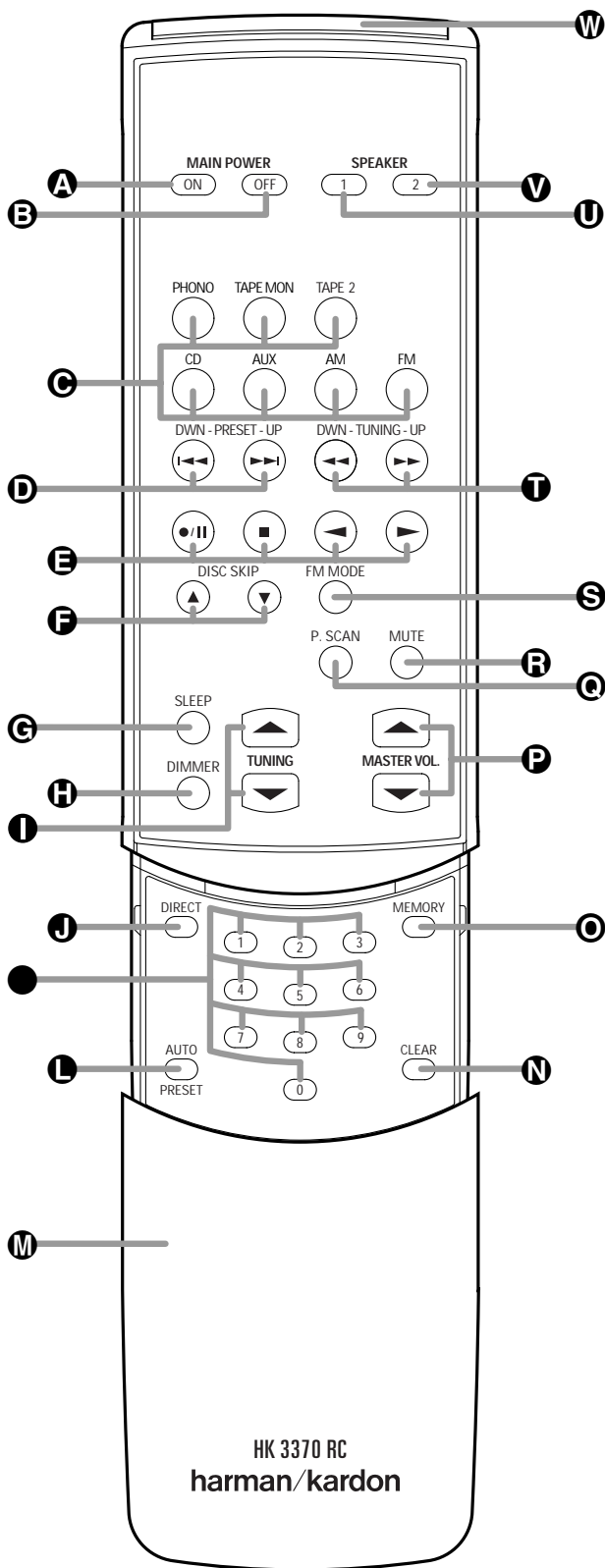

## Remote Control Functions

**A Main Power On:** When the HK 3370 is in the Standby mode, as indicated by the **Power Indicator**  glowing amber, press this button to turn the HK 3370 on.

**B Main Power Off:** When the HK 3370 is turned on, press this button to place it in the Standby mode. Note that in this condition, the unit is still connected to AC Power.

**C Source Selectors:** Press these buttons to select an input source for the HK 3370.

**D Preset Up/Down:** When the tuner is in use, these buttons scroll through the stations that have been programmed into the HK 3370's memory. These buttons also control the track Skip Up and Down on compatible Harman Kardon compact disc players/changers.

**E Transport Controls:** These buttons are used to control Play, Play Forward, Play Reverse, Stop, Pause and Record functions on compatible Harman Kardon compact disc players/changers and cassette tape decks.

**F Disc Skip:** These buttons do not have any functions when controlling the HK 3370, but they operate the Disc Skip functions of compatible Harman Kardon compact disc changers.

**G Sleep Button:** Press this button to place the unit in the Sleep mode. Each press of the button selects the amount of time that will remain before the unit will automatically go into the Standby mode, as shown in the **Information Display** , in the following order:

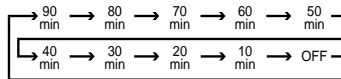

**H Dimmer Button:** Press this button once to reduce the brightness of the front panel display to half the normal intensity. Press it again to turn the front panel display completely off. When the display is completely off, press the button to return to normal brightness.

**I Tuning:** Press these buttons to tune up or down through a selected frequency band.

**J Direct Button:** Press this button to select a radio station by entering its frequency using the **Numeric Keys** . (See page 13 for more information.)

**K Numeric Keys:** These buttons serve as a ten-button numeric keypad to enter tuner preset positions or to tune stations directly.

**L Auto Preset:** When the tuner and FM band have been selected, this button may be used to automatically program the tuner presets for all active stations. To start the auto preset scan, press and hold the button. Note that the **MEMO** and **PRESET** indicators will flash. After a few seconds, the tuner will start to "look" for active stations, as shown by increasing frequency numbers in the Information Display. Release the button and note that the tuner will briefly stop at each active station and add a preset number to the memory. If the FM tuner finds fewer than 30 FM stations with acceptable signal strength, the Auto Preset tuning will scan two more cycles or until the remaining vacant preset memory spaces have been filled with those found in the first scan. The scan will stop when all 30 preset memory spaces have been filled or when three scans through the band have been completed.

**M Secondary Control Cover:** This sliding cover normally is in the "up" position so that it hides the secondary controls. To access these controls, place your thumb on the small recessed area at the top center of the control, and gently press the cover down and towards you.

**N Clear Button:** This button is used to clear preset memory information for the HK 3370's tuner. (See page 14 for more information on tuner presets.)

**O Memory Button:** Press this button to open a memory position that stores a preset location for the HK 3370's tuner. (See page 14 for more information on tuner presets.)

**P Master Volume:** Press these buttons to raise or lower the HK 3370's volume.

**Q P. Scan Button:** Press this button to automatically scan through the list of stations that are programmed into the HK 3370's tuner memory. When the button is pressed, each preset station will play for five seconds before the next station is selected. Press the button again when the desired station is heard to stop the preset scan.

**R Mute Button:** Press this button to momentarily silence the HK 3370.

**S FM Mode Button:** Press this button when the tuner is in use in the FM band to switch to monaural reception if the station is weak and noisy. (See page 13 for more information.)

**T Tuning Up/Down:** When the tuner is in use, these buttons will tune up or down through the selected frequency band. A brief (1/2 second) press of the button will manually tune to the next frequency increment, while pressing and holding the button for a longer period will automatically tune to the next station with a signal strong enough for acceptable reception. These buttons will also control Fast Forward and Fast Reverse (or Rewind) for compatible Harman Kardon compact disc players/changers and cassette tape decks.

**U Speaker 1 Selector:** Press this button to turn the speakers connected to the **Speaker 1 Output** terminals  on or off.

**V Speaker 2 Selector:** Press this button to turn the speakers connected to the **Speaker 2 Output** terminals  on or off.

**W Transmitter Window:** Point this area of the remote toward the receiver when using the remote.

# Front Panel Controls

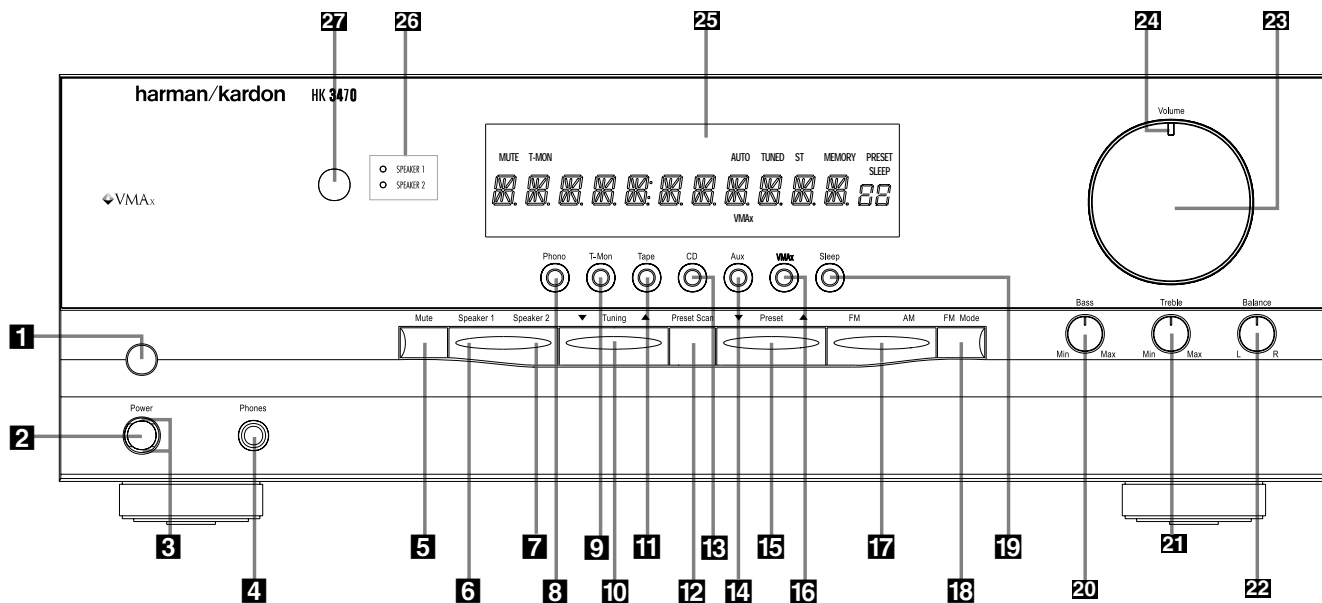

- 1** Main Power Switch
- 2** System Power Control
- 3** Power Indicator
- 4** Headphone Jack
- 5** Mute
- 6** Speaker 1 Selector
- 7** Speaker 2 Selector
- 8** Phono Input Selector
- 9** T-Mon (Tape Monitor) Input Selector

- 10** Tuning Button
- 11** Tape Input Selector
- 12** Preset Scan
- 13** CD Input Selector
- 14** Aux Input Selector
- 15** Preset Selector
- 16** VMAx Selector
- 17** FM/AM Selector
- 18** FM Mode Selector

- 19** Sleep Button
- 20** Bass Control
- 21** Treble Control
- 22** Balance Control
- 23** Volume Control
- 24** Volume/Mute Indicator
- 25** Main Information Display
- 26** Speaker Selection Indicators
- 27** Remote Sensor Window

**1 Main Power Switch:** Press this button to apply power to the HK 3470. When the switch is pressed in, the unit is placed in a Standby mode, as indicated by the **Power Indicator 3** surrounding the **System Power Control 2**. This button MUST be pressed in to operate the unit. To turn the unit off and prevent the use of the remote control, this switch should be pressed until it pops out from the front panel so that the word "OFF" may be read at the top of the switch.

NOTE: In normal operation this switch is left in the "ON" position.

**2 System Power Control:** When the **Main Power Switch 1** is "ON," press this button to turn on the HK 3470; press it again to turn the unit off. Note that the **Power Indicator 3** surrounding the switch will turn green when the unit is on.

**3 Power Indicator:** This LED will light in amber when the unit is in the Standby mode to signal that the unit is ready to be turned on. When the unit is in operation, the indicator will briefly turn red, and then change to green. A red indicator during normal operation means that the unit is in the Protect mode, and should be turned off and then checked for a possible speaker-wire short circuit.

**4 Headphone Jack:** This jack may be used to listen to the HK 3470's output through a pair of headphones. Be certain that the headphones have a standard 1/4" stereo phone plug.

**5 Mute:** Press this button to momentarily silence the speaker output of the HK 3470.

**6 Speaker 1 Button:** Press this button to turn the speakers connected to the **Speaker 1** output terminals **17** on or off.

**7 Speaker 2 Button:** Press this button to turn the speakers connected to the **Speaker 2** output terminals **18** on or off.

## Front Panel Controls

**8 Phono Input Selector:** Press this button to select the output of a turntable that is connected to the **Phono** inputs **6**.

**9 T-Mon (Tape Monitor) Input Selector:** Press this button to listen to the output of a tape recorder connected to the **Tape Monitor** inputs **9**. The T-Mon indicator will light to indicate that the input source is being monitored when the HK 3470 is connected to a three-head tape deck or another unit with off-head playback.

**10 Tuning Button:** Press the left side of the button to tune lower-frequency stations and the right side of the button to tune higher-frequency stations. When a station with a strong signal is tuned, the **TUNED** indicator will light in the **Main Information Display 25**. A brief (1/2 second) press of the button will manually tune to the next frequency increment, while pressing and holding the button for a longer period will automatically tune to the next station with a signal strong enough for acceptable reception.

**11 Tape Input Selector:** Press this button to listen to the output of a tape recorder or other device connected to the **Tape 2** inputs **11**.

**12 Preset Scan:** Press this button to automatically scan through the stations that have been programmed in the HK 3470's memory. The tuner will play five seconds of each station before moving to the next preset station. To stop the scan when the desired station is heard, press the button again. (See page 15 for more information on the tuner memory system.)

**13 CD Input Selector:** Press this button to listen to the output of a CD player connected to the **CD** inputs **7**.

**14 Aux Input Selector:** Press this button to listen to the output of a device connected to the **Aux** inputs **8**.

**15 Preset Selector:** Press this button to step up or down through the list of stations that has been entered into the preset memory. (See page 15 for more information on tuner programming.)

**16 VMaX Selector:** Press this button to engage VMaX processing of a stereo input. The **VMaX Mode Indicator A** will light, and you will notice a wider, more spacious sound field. In order to obtain maximum benefit, you should

be seated midway between the two loudspeakers, and the same distance from the speakers as the speakers are from each other. The speakers must be placed facing parallel and evenly with each other so that their baffles are in the same plane. Press the button again to return to Stereo mode.

**17 FM/AM Selector:** Press this button to select the tuner as the input to the receiver. When the tuner is in use, press this button to change between the AM and FM frequency bands.

**18 FM Mode Selector:** Press this button to select the Stereo or Mono mode for FM tuning. In the STEREO mode, a **Stereo** indicator will light in the **Main Information Display 25**, and stereo reception will be provided when stations are transmitting stereo signals. In the MONO mode, the left and right signals from stereo broadcasts will be mixed together and reproduced through all channels. Select MONO for better reception of weak signals. VMaX will have no effect in MONO mode.

**19 Sleep Button:** Press this button to place the unit in the Sleep mode. Each press of the button selects the amount of time that will remain before the unit automatically goes into the Standby mode, as shown in the **Main Information Display 25**, in the following order:

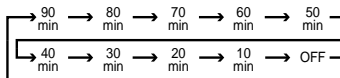

**20 Bass Control:** Turn this control to modify the low-frequency output of the left and right channels by as much as  $\pm 10$ dB. Set this control to a suitable position for your taste and room acoustics.

**21 Treble Control:** Turn this control to modify the high-frequency output of the left and right channels by as much as  $\pm 10$ dB. Set this control to a suitable position for your taste and room acoustics.

**22 Balance Control:** Turn this control to change the relative volume for the left and right channels.

**23 Volume Control:** Turn the knob clockwise to increase volume, counterclockwise to decrease the volume.

**24 Volume/Mute Indicator:** This indicator will glow green when the HK 3470 is turned on. Its position will enable you to judge the relative volume of the unit even when the speakers are muted or turned off. When the indicator is pointing toward the left, as in an "8 o'clock" position, the volume is low; when it is pointing to the right, as in a "3 o'clock" position, the volume is loud. When the unit has been muted by pressing the **Mute** button **5**, the indicator will flash.

**25 Main Information Display:** This display delivers messages and status indications to help you operate the receiver.

**26 Speaker Selection Indicators:** These indicators light as a green LED next to the designation for each speaker pair to show when they are active. Press the **Speaker 1 6** or **Speaker 2 7** Selectors to activate either pair of speakers. Both sets of speakers may be selected simultaneously as long as all speakers have a nominal impedance of 8 ohms or greater. However, occasionally the actual impedance will vary, depending upon the program material. If the impedance drops to a point where there may be potential damage to the equipment, the HK 3470 will go into protect mode.

**27 Remote Sensor Window:** The sensor behind this window receives infrared signals from the remote control. Aim the remote at this area and do not block or cover it unless an external remote sensor is installed.

# Front Panel Information Display

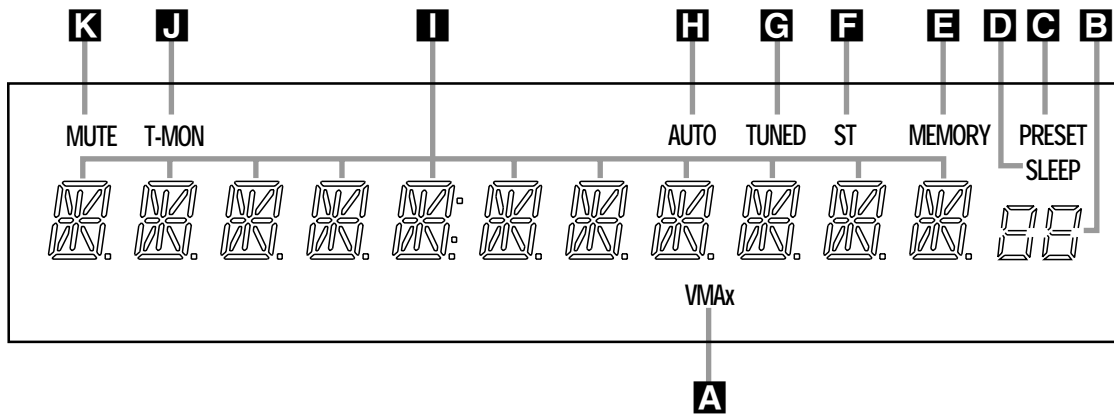

- A** VMAx Mode Indicator
- B** Preset Number/Sleep Timer
- C** Preset Indicator
- D** Sleep Indicator
- E** Memory Indicator
- F** Stereo Indicator
- G** Tuned Indicator
- H** Auto Indicator
- I** Main Information Display
- J** Tape Monitor (T-Mon) Indicator
- K** Mute Indicator

**A VMAx Mode Indicator:** This indicator lights when the VMAx mode is in use. (See page 14 for a description of the VMAx Mode.)

**B Preset Number/Sleep Timer:** When the tuner is in use, these numbers indicate the specific preset memory location in use. (See page 15 for more information on preset stations.) When the Sleep function is in use, these numbers show how many minutes remain before the unit goes into the Standby mode.

**C Preset Indicator:** This indicator lights when the tuner is in use to show that the Preset Number/Sleep Timer **B** is showing the station's preset memory number. (See page 15 for more information on tuner presets.)

**D Sleep Indicator:** This indicator lights when the Sleep function is in use. The numbers in the Preset Number/Sleep Timer Indicators will show the minutes remaining before the HK 3470 goes into the Standby mode. (See page 14 for more information on the Sleep function.)

**E Memory Indicator:** This indicator flashes when entering presets and other information into the tuner's memory.

**F Stereo Indicator:** This indicator lights when an FM station is being tuned in stereo.

**G Tuned Indicator:** This indicator lights when a station is being received with sufficient signal strength to provide acceptable listening quality.

**H Auto Indicator:** This indicator lights when the tuner's Auto mode is in use.

**I Main Information Display:** This display shows messages relating to the status, input source, tuner or other aspects of the HK 3470's operation.

**J Tape Monitor (T-Mon) Indicator:** When used with three-head cassette decks, or other recording devices that offer immediate playback of the recording as it is being made, the HK 3470 allows you to monitor a recording rather than merely listening to the input source, or waiting until the recording session is complete in order to hear the recording. Press the **Tape Monitor Input Selector** **9** **C**, and the **T-Mon Indicator** **J** will light to remind you that you are monitoring the recording. Press the **Tape Monitor Input Selector** **9** **C** again to hear the input source.

**K Mute Indicator:** This indicator lights to remind you that the HK 3470's output has been silenced by pressing the **Mute** button **5** **R**. Press the Mute button again to return to the previously selected output level.

# Rear Panel Connections

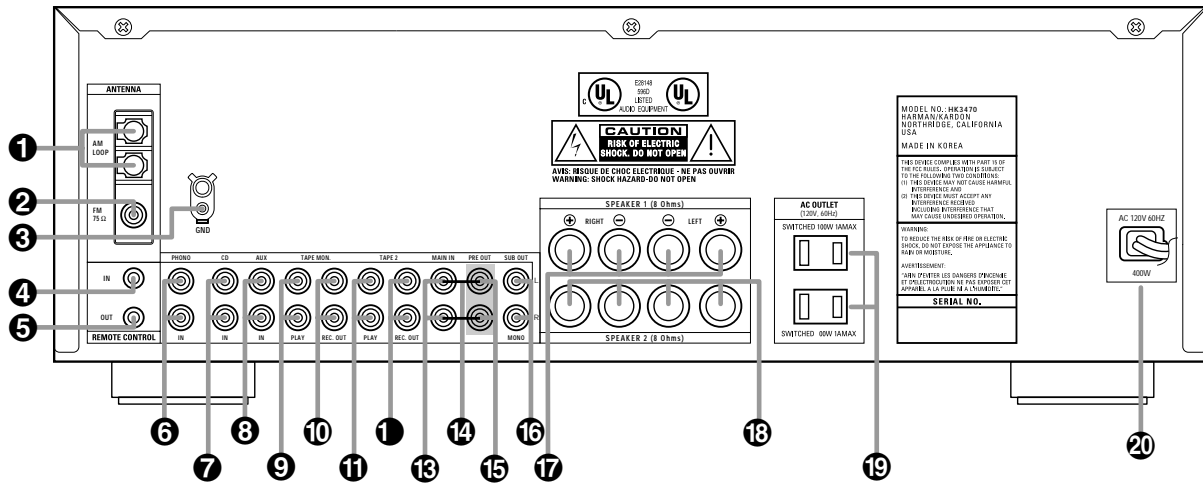

- 1 AM Antenna
- 2 FM Antenna
- 3 Phono Ground
- 4 Remote IR In
- 5 Remote IR Out
- 6 Phono Inputs
- 7 CD Inputs

- 8 Aux Inputs
- 9 Tape Monitor Play/In
- 10 Tape Monitor Record/Out
- 11 Tape 2 Play/In
- 12 Tape 2 Record/Out
- 13 Main In
- 14 Pre-Out/Main-In Jumper Pins

- 15 Preamp Out
- 16 Subwoofer Out
- 17 Speaker 1 Terminals
- 18 Speaker 2 Terminals
- 19 Accessory Outlets
- 20 Power Cable

## Rear Panel Connections

**1 AM Antenna:** Connect the AM loop antenna supplied with the receiver to these terminals. If an external AM antenna is used, make connections to the **AM** and **GND** terminals in accordance with the instructions supplied with the antenna.

**2 FM Antenna:** Connect an indoor or external FM antenna to this terminal.

**3 Phono Ground:** Connect the ground wire from a turntable to this terminal to reduce system hum.

**4 Remote IR In:** If the HK 3470's front panel IR sensor is blocked due to cabinet doors or other obstructions, an external IR sensor may be used. Connect the output of the sensor to this jack.

**5 Remote IR Out:** This connection permits the IR sensor in the receiver to serve other remote-controlled devices. Connect this jack to the "IR IN" jack on Harman Kardon or other compatible equipment.

**6 Phono Inputs:** Connect the outputs of your turntable or tonearm to these jacks. Note that only turntables with Moving Magnet (MM) type cartridges may be used.

**7 CD Inputs:** Connect these jacks to the output of a compact disc player or CD changer.

**8 Aux Inputs:** Connect these jacks to the line-level output of any audio device such as a TV, cable converter, portable audio player or MP3 player.

**9 Tape Monitor Play/In:** Connect these jacks to the Play/Out jacks of an audio recorder.

**10 Tape Monitor Record/Out:** Connect these jacks to the Rec/In jacks of an audio recorder.

NOTE: When these jacks are connected to a three-head recorder or another device with off-head playback, it will be possible to monitor the source being recorded.

**11 Tape 2 Play/In:** Connect these jacks to the PLAY/OUT jacks of a second audio recorder.

**12 Tape 2 Record/Out:** Connect these jacks to the Rec/In jacks of a second audio recorder.

**13 Main In:** These jacks are the input to the HK 3470's power amplifier. Unless an external power amplifier is used, the jumper pins should remain connected to the **Preamp Out** jacks **15**.

**14 Pre-Out/Main-In Jumper Pins:** These pins connect the receiver's preamp and amplifier sections. Unless an external amplifier, equalizer or speaker processor is used, they should be left connected. See page 13 for more information on external amplifier connections.

**15 Preamp Out:** These jacks provide an output for the left and right channels to an optional external amplifier. In normal operation, unless an external power amplifier is used, the jumper pins should remain connected to the **Main In** jacks **13**.

**16 Subwoofer Out:** Connect these jacks to the line-level input of a powered subwoofer. If an external subwoofer amplifier is used, connect this jack to the subwoofer amplifier input. When a single, mono subwoofer is used, make the connection to the bottom jack.

**17 Speaker 1 Terminals:** Connect these terminals to the appropriate terminals on your speakers.

**18 Speaker 2 Terminals:** Connect these terminals to the appropriate terminals on your speakers.

**19 Accessory Outlets:** These outlets may be used to power low-current draw devices such as CD players or cassette decks. The power to these outlets remains on as long as the receiver itself is on. When the receiver is turned off, or placed in the Standby mode, power to these outlets is removed.

NOTE: The power consumption of the devices plugged into these outlets should not exceed 100 watts.

**20 Power Cable:** Connect the AC plug to a nonswitched AC wall output.



# Remote Control Functions

- A** Main Power On
- B** Main Power Off
- C** Source Selectors
- D** Preset Up/Down
- E** Transport Controls
- F** Disc Skip
- G** Sleep Button
- H** Dimmer Button
- I** Tuning
- J** Direct Button
- K** Numeric Keys
- L** Auto Preset
- M** Secondary Control Cover
- N** Clear Button
- O** Memory Button
- P** Master Volume
- Q** P. Scan Button
- R** Mute Button
- S** FM Mode Button
- T** VMAx Selector
- U** Tuning Up/Down
- V** Learn Button
- W** Speaker 1 Selector
- X** Speaker 2 Selector
- Y** Transmitter Window
- Z** LED Indicator

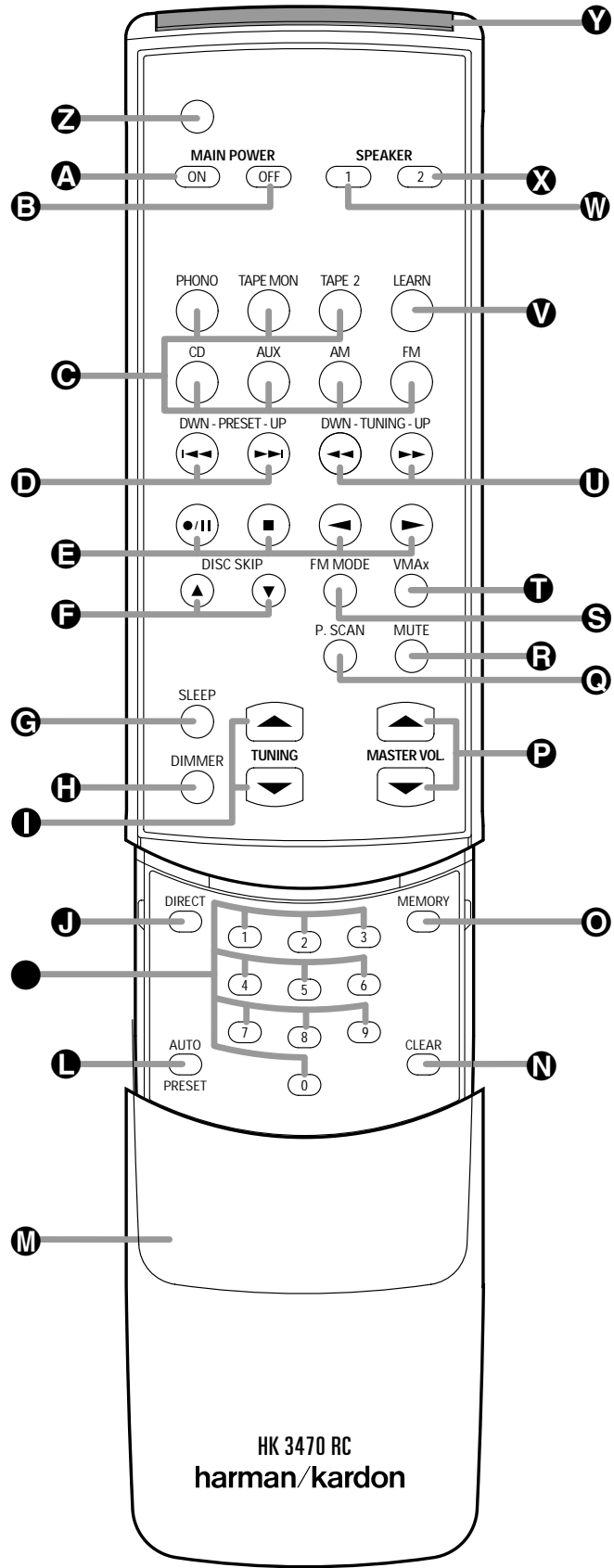

HK 3470 RC  
harman/kardon

## Remote Control Functions

**A Main Power On:** When the HK 3470 is in the Standby mode, as indicated by the **Power Indicator** **B** glowing amber, press this button to turn the HK 3470 on.

**B Main Power Off:** When the HK 3470 is turned on, press this button to place it in the Standby mode. Note that in this mode, the unit is still connected to AC Power.

**C Source Selectors:** Press these buttons to select an input source for the HK 3470.

**D Preset Up/Down:** When the tuner is in use, these buttons scroll through the stations that have been programmed into the HK 3470's memory. These buttons also control the track Skip Up and Down on compatible Harman Kardon compact disc players and changers.

**E Transport Controls:** These buttons are used to control Play, Play Forward, Play Reverse, Stop, Pause and Record functions on compatible Harman Kardon compact disc players/changers and cassette tape decks. Also, when a compatible Harman Kardon compact disc player or changer, or cassette deck, has been selected using the **Source Selectors** **C**, additional transport control functions are available using the **Preset Up/Down** **D** and **Tuning Up/Down** **U** buttons.

**F Disc Skip:** These buttons do not have any functions when controlling the HK 3470, but they operate the Disc Skip functions of compatible Harman Kardon compact disc changers.

**G Sleep Button:** Press this button to place the unit in the Sleep mode. Each press of the button selects the amount of time that will remain before the unit will automatically go into the Standby mode, as shown in the **Main Information Display** **25**, in the following order:

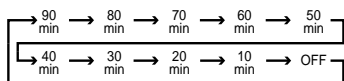

**H Dimmer Button:** Press this button once to reduce the brightness of the front panel display to half the normal intensity. Press it again to turn the front panel display completely off. When the display is completely off, press the button to return to normal brightness.

**I Tuning:** Press these buttons to tune up or down through a selected frequency band.

**J Direct Button:** Press this button to select a radio station by entering its frequency using

the **Numeric Keys** **K**. (See page 15 for more information.)

**K Numeric Keys:** These buttons serve as a ten-button numeric keypad to enter tuner preset positions or to tune stations directly.

**L Auto Preset:** When the tuner and FM band have been selected, this button may be used to automatically program the tuner presets for all active stations. To start the auto preset scan, press and hold the button. Note that the **MEMO** and **PRESET** indicators will flash. After a few seconds, the tuner will start to "look" for active stations, as shown by increasing frequency numbers in the Main Information Display. Release the button and note that the tuner will briefly stop at each active station and add a preset number to the memory. If the FM tuner finds fewer than 30 FM stations with acceptable signal strength, the Auto Preset tuning will scan two more cycles or until the remaining vacant preset memory spaces have been filled with those found in the first scan. The scan will stop when all 30 preset memory spaces have been filled or when three scans through the band have been completed.

**M Secondary Control Cover:** This sliding cover normally is in the "up" position so that it hides the secondary controls (the Direct button, Numeric Keys, Auto Preset button, Clear button and Memory button) **J●LNO**. To access these controls, place your thumb on the small recessed area at the top center of the control, and gently press the cover down and towards you.

**N Clear Button:** This button is used to clear preset memory information for the HK 3470's tuner. (See page 15 for more information on tuner presets.)

**O Memory Button:** Press this button to open a memory position that stores a preset location for the HK 3470's tuner. (See page 15 for more information on tuner presets.)

**P Master Volume:** Press these buttons to raise or lower the HK 3470's volume.

**Q P. Scan Button:** Press this button to automatically scan through the list of stations that are programmed into the HK 3470's tuner memory. When the button is pressed, each preset station will play for five seconds before the next station is selected. Press the button again when the desired station is heard to stop the preset scan.

**R Mute Button:** Press this button to momentarily silence the HK 3470.

**S FM Mode Button:** Press this button when the tuner is in use in the FM band to switch to monaural reception if the station is weak and noisy. (See page 15 for more information.)

**T VMAx Selector:** Press this button to engage VMAx processing of a stereo input. The **VMAx Mode Indicator** **A** will light, and you will notice a wider, more spacious sound field. In order to obtain maximum benefit, you should be seated midway between the two loudspeakers, and the same distance from the speakers as the speakers are from each other. The speakers must be placed facing parallel and evenly with each other so that their baffles are in the same plane. Press the button again to return to Stereo mode.

**U Tuning Up/Down:** When the tuner is in use, these buttons will tune up or down through the selected frequency band. A brief (1/2 second) press of the button will manually tune to the next frequency increment, while pressing and holding the button for a longer period will automatically tune to the next station with a signal strong enough for acceptable reception. These buttons will also control Fast Forward and Fast Reverse (or Rewind) for compatible Harman Kardon compact disc players/changers and cassette tape decks.

**V Learn Button:** This button is used when you wish to program codes from another device's remote control into the HK 3470 remote. The simple procedure is described on page 18.

**W Speaker 1 Selector:** Press this button to turn the speakers connected to the **Speaker 1 Output** terminals **17** on or off.

**X Speaker 2 Selector:** Press this button to turn the speakers connected to the **Speaker 2 Output** terminals **18** on or off.

**Y Transmitter Window:** Point this area of the remote toward the receiver when using the remote.

**Z LED Indicator:** This indicator will light or blink to confirm various steps in the learning process as the HK 3470 remote is programmed. It will also flicker when a key is pressed during normal operation to indicate that it is transmitting an infrared code.

## TROUBLESHOOTING GUIDE

This unit is designed for trouble-free operation. Most problems users encounter are due to operating errors. So, if you have a problem, first check this list for a possible solution. If the problem persists, consult your authorized Harman Kardon service center.

If the problem is..	Make sure that the..
No lights appear when POWER button is pressed	Unit is plugged into a live outlet Main power switch is pressed in
No sound is heard	Unit has not been muted Correct input function selector button has been pressed Volume is turned up The speakers have been turned on using the Speaker Selectors
No output from one or more channels	Cables are not defective: check/replace speaker cables
Tuner sound has a large amount of interference, or The "Stereo" display is not illuminated, or Tuner sound distorts and/or volume level is too low	The antenna is properly connected The antenna is properly located The antenna is set in the proper direction The antenna is adequate to receive the desired station
Tuner is intermittent or continuously buzzing or hissing	The unit is away from fluorescent lights, TVs, motors and other electrical appliances
Remote does not function correctly	Batteries are not weak, and replace them if necessary
Cassette or CD sounds distorted	Cassette deck or CD player has not been plugged into the <b>Phono Input ⑥</b> (only use the outputs of a turntable or tonearm with the <b>Phono Input ⑥</b> )
Turntable sounds distorted	Turntable has been plugged into the <b>Phono Input ⑥</b> , as the other inputs are not compatible with turntable signal levels

## hk3370/hk3470 Microprocessor Reset Instructions

To correct this problem, first unplug the unit from the AC wall outlet and wait at least three minutes. After the pause, reconnect the AC power cord and check the unit's operation. If the system still malfunctions, first turn the unit off by pressing the **Main Power Switch** and then releasing it so that it extends out beyond the front panel and the word "OFF" is visible in red lettering at the top of the switch. Next, press and hold the **T•Mon** and **CD Input Selector** buttons on the front panel ONLY. While holding these buttons in, press the **Main Power Switch** in until it latches so that the button is flush with the front panel. The Information Display will briefly show the word **RESET**, and then return to normal operation.

**harman/kardon****TECH TIPS****Troubleshooting tips and solutions to common service problems**

For models:

TIP# HKTT2003-01 Rev5

AVR7000/7200/7300/8000	AVR10
AVR100/200/300/500	DPR1001
AVR110/210/310/510	DPR1005
AVR120/220/320/520	DPR2005
AVR125/225/325/525	HK3370/3470/3375/3475
AVR130/230/330/430/630	HK3250
AVR135/235/335/435/635	

**Subject:** Backup Memory on AVR/DPR/HK series receivers

**In the event of the complaint: “the receiver is losing its memory (any programmed system settings) when the unit is turned off, or after the unit is unplugged (briefly\*)”:**

Check and replace:

Model	Designator	Location	Description	Part number
AVR10	C712 D709	Front PCB	0.047 Farad 5.5v capacitor and 1N4148 diode	#3439247315 #2058322101
AVR7000	C730	Front PCB	0.047 Farad 5.5v capacitor	# P10790-ND or # J3432147324X
AVR7200	C106	Front PCB	0.047 Farad 5.5v capacitor	# P10790-ND
AVR7300	C657	DSP PCB	0.047 Farad 5.5v capacitor	# H01-CEZXA0479MN-5
AVR8000	C726	Front PCB	0.047 Farad 5.5v capacitor	# 55230310NR or # P10790-ND
AVR100/200	C412	Front PCB	0.047 Farad 5.5v capacitor	# CEGT-B473J-0J0
AVR300	C906	Front PCB	0.1Farad 5.5v capacitor	# J4433210421X or # P10791-ND
AVR500	C906	Front PCB	0.1Farad 5.5v capacitor	# J4433210421X or # P10791-ND
AVR110/210/310/510 AVR120/220/320/520	C216	Front PCB	0.047 Farad 5.5v capacitor	# P10790-ND
AVR125/225	C734,C885	Front PCB	two 0.1F capacitors in parallel	# BCESOHD104
AVR325/525	C106	Front PCB	0.047 Farad 5.5v capacitor	# P10790-ND
AVR130/230/330	BAT1	Front PCB	3.6v Battery	# HABGP40BVH3A3H
AVR135/235/335	BAT1	Front PCB	3.6v Battery	# HGP15BNH3A3H
AVR430/630	C657	DSP PCB	0.047 Farad 5.5v capacitor	# CEZXA0479MN-5
AVR435/635	C557	DSP PCB	0.047 Farad 5.5v capacitor	# H03-CEZXA0479MN-0
DPR1001	BC601	Main PCB	0.1Farad 5.5v capacitor	# CEGT-B104J-0J0
DPR1005/2005	C437	Processor PCB	0.047 Farad 5.5v capacitor	# CEZXA0479MN-5
HK3370/3470	C301	Front PCB	0.1Farad 5.5v capacitor	# CEGT-B104J-0J0
HK3375/3475	C301	Front PCB	0.1Farad 5.5v capacitor	# CEGT-B104J-0J0
HK3250	C712 D709	Front PCB	0.047 Farad 5.5v capacitor and 1N4148 diode	#3439247315 #2058322101

\* After approximately two weeks of being disconnected from AC supply, even a normally functioning receiver may lose any programmed settings and switch to default settings. (Four weeks for the DPR1005 & 2005)

## 2. Alignment Procedures

### 1. Test Equipment Required.

- AM Standard Signal Generator (AM SSG)
- Oscilloscope
- AC Voltmeter
- FM Standard Signal Generator (FM SSG)
- Stereo Modulator
- Audio Generator
- Distortion Meter
- DC Voltmeter
- Frequency Counter

Note: Disconnect external FM antenna prior to alignment

### 2. Alignment and Test Points

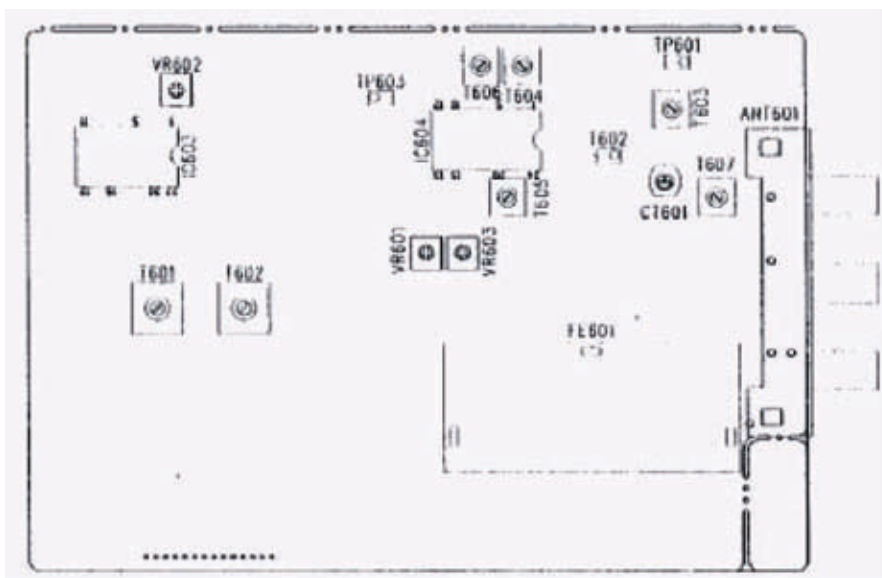

### 3. AM IF and RF Alingment

Preparation

1. Output of signal Generator should not be higher than necessary to obtain an optimum output reading.
2. Signal Generator Modulation: 30%
3. Switch: Press to AM.

Step	Signal Generator Frequency	Receiver Frequency on the Display	Equipment Connection	Adjustment Point	Adjust for
1	990KHz (400Hz,Mod.)	520KHz	DC Voltmeter TP601	T603	1.2V reading Maximum
2	600KHz (400Hz,Mod.)	600KHz	AC Voltmeter to TAPE OUT jack	T607	reading Maximum
3	1400KHz (400Hz,Mod.)	400KHz	AC Voltmeter to TAPE OUT jack	CT601	reading Maximum
4	990KHz (400Hz,Mod.)	990KHz	AC Voltmeter to TAPE OUT jack	T605	reading FL display "TUNED"
5	990KHz (400Hz,Mod.)	990KHz	same as Step 1	VR603	Indicator on receiver with AM SSG Output level of 800 $\mu$ V/m

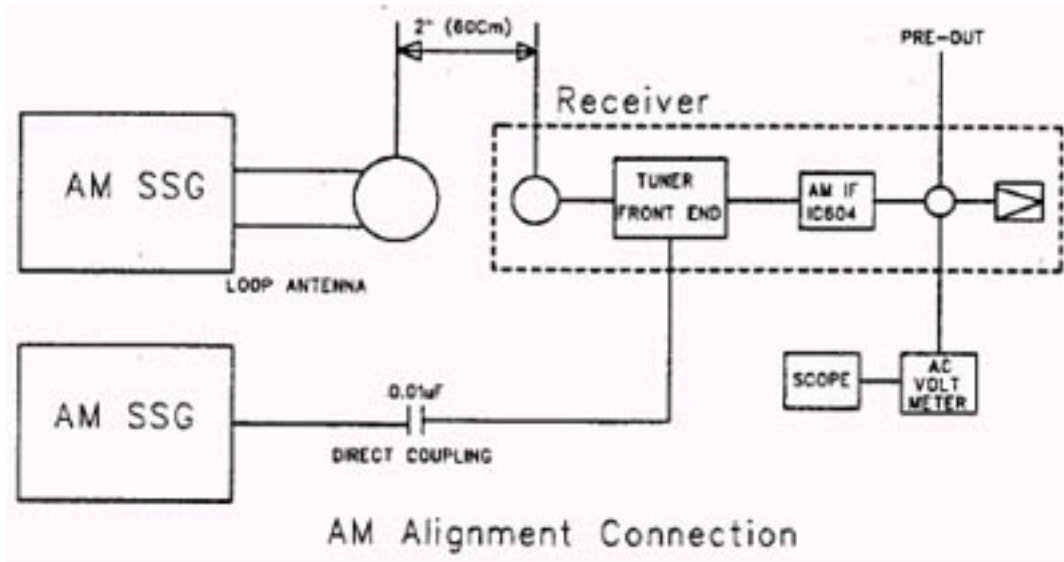

**4. FM IF Alignment**

Preparation

1. Signal Generator output should be no higher than necessary to obtain an optimum output reading.
2. Switch Press to FM
3. Signal Generator Deviation: 75KHz (HK 3370), 40KHz (HK 3470)

Step	Signal Generator Frequency	Receiver Frequency on the Display	Equipment Connection	Adjustment Point	Adjust for
1	98.0 MHz (1KHz, Mod.)	98.0 MHz	DC Voltmeter to TP602	T606	Zero reading on DC Voltmeter
2	98.0 MHz (1KHz, Mod.)	98.0 MHz	Distortion meter to TAPE OUT jack	T604	Minimum distortion
3	98.0 MHz (1KHz, Mod.)	98.0 MHz	Same as Step 1	VR601	FL display "TUNED" Indicator on receiver with FM SSG Output level of 35.2dbf

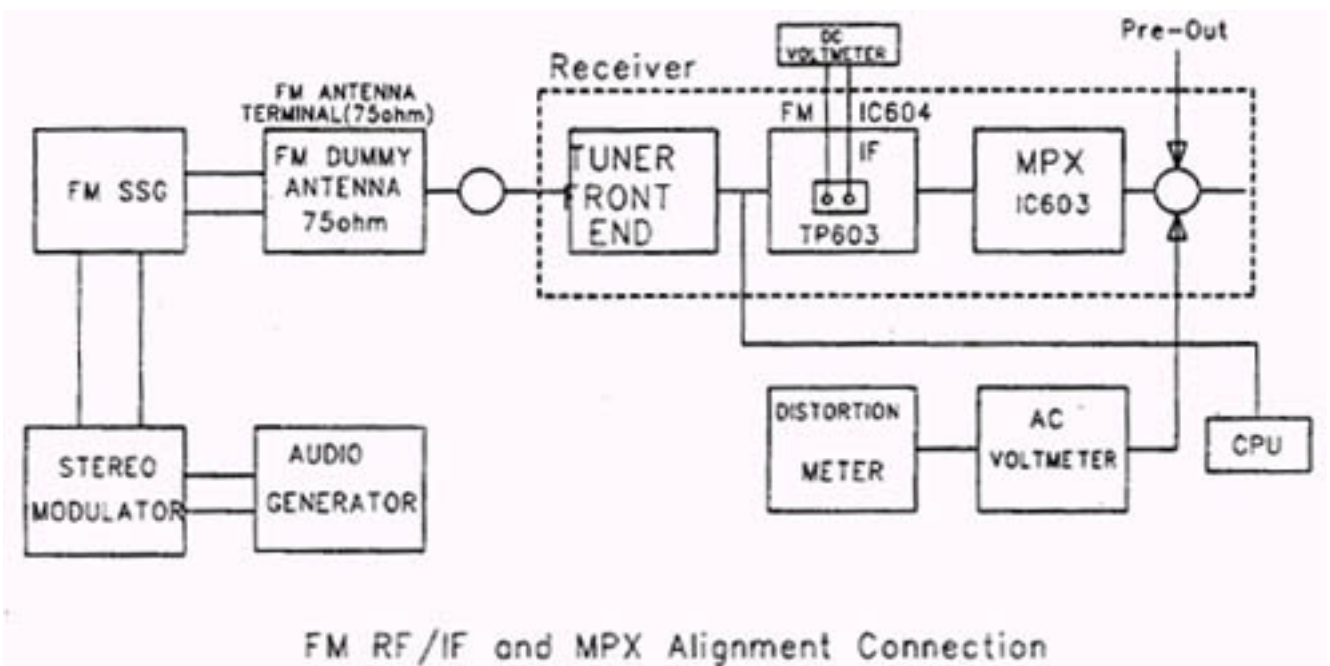

**5. MPX Alignment, SM Alignment**

Preparation

1. Switch: Press to FM
2. Tuner for 98MHz on band.
3. Signal Generator output level: 1000 $\mu$ V
4. Deviation: 75KHz (HK 3370), 40KHz (HK 3470) at 100% modulation to composite signal.
5. Connect Signal Generator to FM antenna terminal through FM dummy antenna (75 $\Omega$ ).

Step	19KHz Modulation Level	Signal Generator Frequency Setting	Equipment Connection	Adjustment Point	Adjust for
1	7.5KHz, Mod.	Composite to channel 1KHz R	AC Voltmeter to TAPE OUT jack of R channel		Adjust for about 450mV of audio output
2	7.5KHz, Mod.	Composite to channel 1KHz L	AC Voltmeter to TAPE OUT jack of R channel	VR602	AC Voltmeter reading should be at least 40dB below.
3	7.5KHz, Mod.	Composite to channel 1KHz R	AC Voltmeter to TAPE OUT jack of L channel	VR602	Same as Step 2
If you could not obtain -40dB reading in Steps 2 and 3 (compared with Step 1), read just VR603 until you obtain -40dB readings for both steps 2 and 3. Normal is -45dB.					

4. BLOCK DIAGRAM

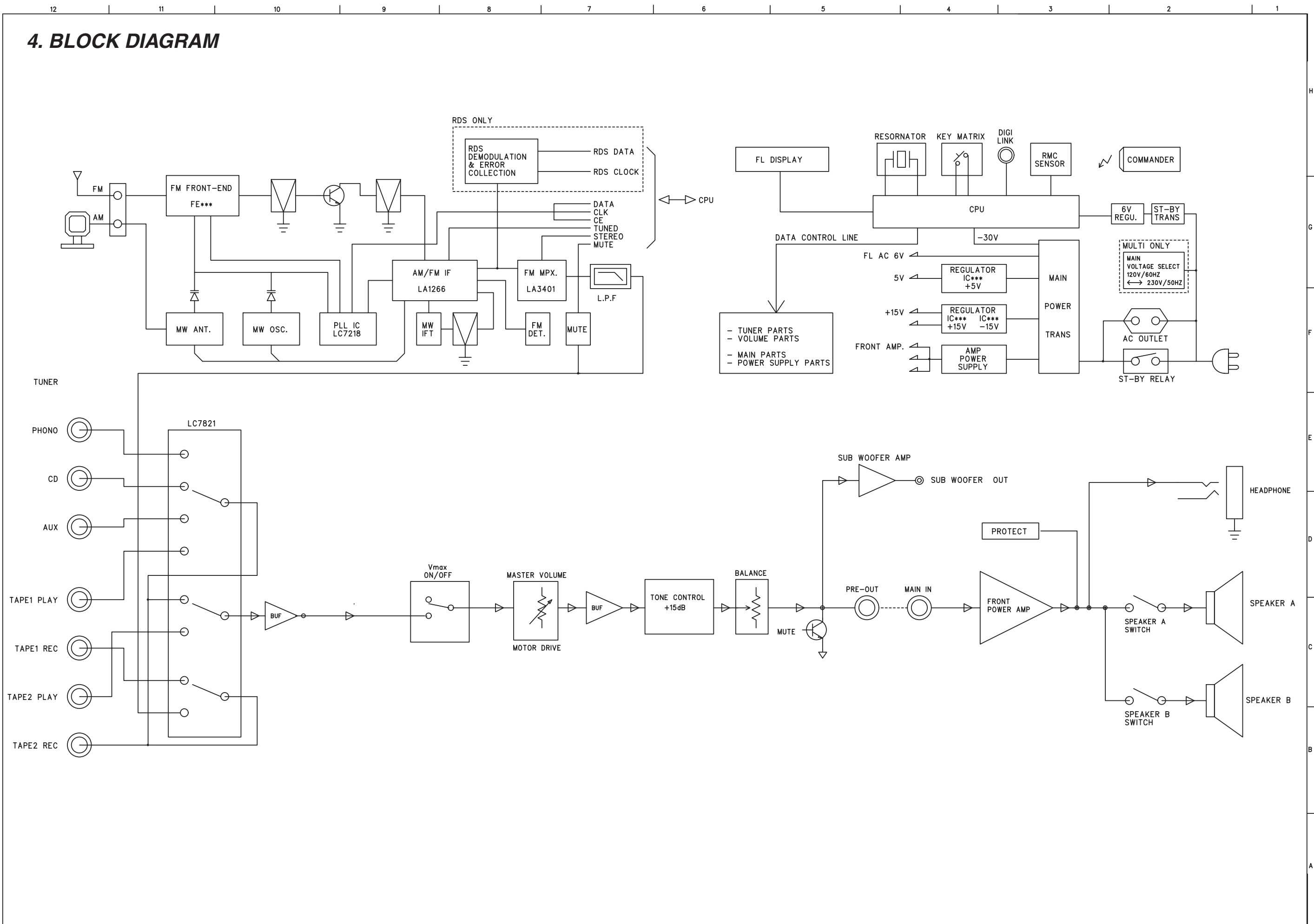



NO	PARTS NAME	PART NO	Q'TY	REMARK	NO	PARTS NAME	PART NO	Q'TY	REMARK	NO	PARTS NAME	PART NO	Q'TY	REMARK
1	1				2					3				
1	1	MJAF-16100-024	1	ABS	28	RADIATOR-TR	MEAC-08215-004	1	AL	g	STANDBY P.C.BOARD	***	1	***
2	2	MAAF-16130-014	1	ACRYL	29	HEAT-SINK(TR)	MEAC-12693-004	1	AL	h	AMP P.C.BOARD	***	1	***
3	3	n/a	4	***	30	PLUG-RCA	PLRC-00020-S30	2	***	i	MAIN P.C.BOARD	***	1	***
4	4	n/a	1	***	31	JACK-CONNECT	MMAC-17070-004	2	***	j	TUNER P.C.BOARD	***	1	***
5	5	MJAF-16070-024	3	ABS	32	CHASSIS-BOTTOM	MPAC-04812-002	1	US Co					
6	6	MAAF-03600-012	1	ACRYL	33	CUSHION-A(SHEET-SIDE)	MRAG-13050-004	2	FELT					
7	7	MLAG-13850-024	1	AL	34	CUSHION-A(SIDE)	MRAG-13250-004	2	EVA					
8	8	MAAF-17070-004	1	PE	35	FOOT(A)	MJAF-15640-014	4	ABS					
9	9	MJAF-08880-013	1	ABS	36	SUPPORT-PCB	MJAF-16140-004	6	ABS					
10	10	MAAF-17040-014	1	PVC	37	CHASSIS-PANEL	MPAC-04760-003	1	US Co					
11	11	MJAF-06570-011	1	ABS	38	POWER-TRANS	n/a	1	***					
12	12	MPAC-16880-004	1	ET-HD	39	CORD-BUSH	MJAG-00280-003	1	***					
13	13	MJAF-08870-013	1	ABS	40	CORD-AC ASS'y	n/a	1	***					
14	14	MJAF-03580-012	1	ABS	41	CHASSIS-BACK	MPAC-05040-012	1	SECC					
15	15	MRAG-13830-004	2	EVA	42	CUSHION-A(SHEET-TOP)	MRAG-13040-004	1	FELT					
16	16	MRAG-13840-004	1	EVA	43	TERMINAL-GND	MMAC-12060-004	1	***					
17	17	MJAF-17030-004	1	ABS	44	CHASSIS-TOP	MPAC-04950-012	1	VCM					
18	18	MJAF-16050-024	1	ABS	a	VOLUME2 P.C.BOARD	***	1	***					
19	19	MJAF-16980-014	1	ABS	b	VOLUME P.C.BOARD	***	1	***					
20	20	MAAF-16990-014	1	ACRYL	c	PHONE P.C.BOARD	***	1	***					
21	21	MEAC-05060-002	1	AB063	d	FRONT P.C.BOARD	***	1	***					
22	22	***	1	***	e	PHONE P.C.BOARD	***	1	***					
23	23	***	4	***	f	POWER P.C.BOARD	***	1	***					
24	24	***	2	***										
25	25	***	4	***										
26	26	MPAC-16220-004	4	US Co										
27	27	MEAC-08212-004	4	AL										

6. EXPLODED VIEW

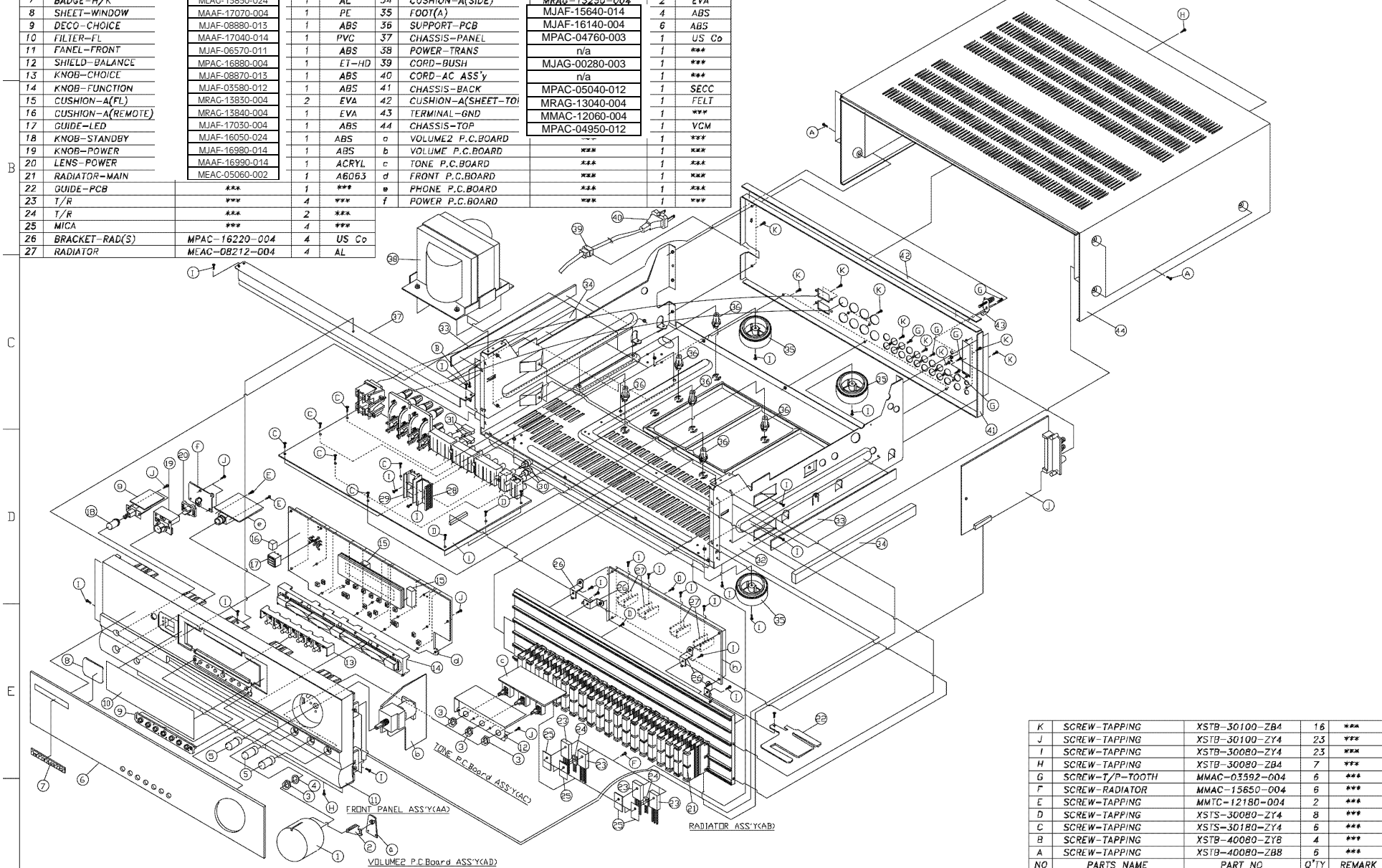

K	SCREW-TAPPING	XSTB-30100-ZB4	16	***
J	SCREW-TAPPING	XSTB-30100-ZY4	23	***
I	SCREW-TAPPING	XSTB-30080-ZY4	23	***
H	SCREW-TAPPING	XSTB-30080-ZB4	7	***
G	SCREW-T/P-TOOTH	MMAC-03592-004	6	***
F	SCREW-RADIATOR	MMAC-13650-004	6	***
E	SCREW-TAPPING	MMTC-12180-004	2	***
D	SCREW-TAPPING	XSTS-30080-ZY4	8	***
C	SCREW-TAPPING	XSTS-30180-ZY4	6	***
B	SCREW-TAPPING	XSTB-40080-ZYB	4	***
A	SCREW-TAPPING	XSTB-40080-ZBB	6	***
NO	PARTS NAME	PART NO	Q'TY	REMARK

1				2				3				4				5				6				7				8			
NO	PARTS NAME	PART NO	Q'TY	REMARK	NO	PARTS NAME	PART NO	Q'TY	REMARK	NO	PARTS NAME	PART NO	Q'TY	REMARK	NO	PARTS NAME	PART NO	Q'TY	REMARK	NO	PARTS NAME	PART NO	Q'TY	REMARK	NO	PARTS NAME	PART NO	Q'TY	REMARK		
1	KNOB-VOLUME	MJAF-16100-024	1	ABS	28	RADIATOR-TR	MEAC-08215-004	1	AL	g	STANDBY P.C.BOARD	***	1	***	h	AMP P.C.BOARD	***	1	***	i	MAIN P.C.BOARD	***	1	***	j	TUNER P.C.BOARD	***	1	***		
2	LENS-VOLUME	MAAF-16130-014	1	ACRYL	29	HEAT-SINK(TR)	MEAC-12693-004	1	AL																						
3	NUT	n/a	4	***	30	PLUG-RCA	PLRC-00020-S30	2	***																						
4	WASHER	n/a	1	***	31	JACK-CONNECT	MMAC-17070-004	2	***																						
5	KNOB-BALANCE	MJAF-16070-024	3	ABS	32	CHASSIS-BOTTOM	MPAC-04812-002	1	US Co																						
6	WINDOW-FL	MAAF-03600-022	1	ACRYL	33	CUSHION-A(SHEET-SIDE)	MRAC-13050-004	2	FELT																						
7	BADGE-H/K	MLAG-13850-024	1	AL	34	CUSHION-A(SIDE)	MRAG-13250-004	2	EVA																						
8	SHEET-WINDOW	MAAF-17070-004	1	PL	35	FOOT(A)	MJAF-15640-014	4	ABS																						
9	DECO-CHOICE	MJAF-08880-013	1	ABS	36	SUPPORT-PCB	MJAF-16140-004	6	ABS																						
10	FILTER-FL	MAAF-17040-014	1	PVC	37	CHASSIS-PANEL	MPAC-04760-003	1	US Co																						
11	PANEL-FRONT	MJAF-06570-011	1	ABS	38	POWER-TRANS	n/a	1	***																						
12	SHIELD-BALANCE	MPAC-16880-004	1	ET-HD	39	CORD-BUSH	MJAG-00280-003	1	***																						
13	KNOB-CHOICE	MJAF-08870-013	1	ABS	40	CORD-AC ASS'y	n/a	1	***																						
14	KNOB-FUNCTION	MJAF-03580-012	1	ABS	41	CHASSIS-BACK	MPAC-05040-012	1	SECC																						
15	CUSHION-A(FL)	MRAG-13830-004	2	EVA	42	CUSHION-A(SHEET-TOP)	MRAG-13040-004	1	FELT																						
16	CUSHION-A(REMOTE)	MRAG-13840-004	1	EVA	43	TERMINAL-GND	MPAC-12060-004	1	***																						
17	GUIDE-LED	MJAF-17030-004	1	ABS	44	CHASSIS-TOP	MPAC-04950-012	1	VCM																						
18	KNOB-STANDBY	MJAF-16050-024	1	ABS	a	VOLUME2 P.C.BOARD	***	1	***																						
19	KNOB-POWER	MJAF-16980-014	1	ABS	b	VOLUME P.C.BOARD	***	1	***																						
20	LENS-POWER	MAAF-16990-014	1	ACRYL	c	PHONE P.C.BOARD	***	1	***																						
21	RADIATOR-MAIN	MEAC-05060-002	1	A6063	d	FRONT P.C.BOARD	***	1	***																						
22	GUIDE-PCB	***	1	***	e	PHONE P.C.BOARD	***	1	***																						
23	T/R	***	4	***	f	POWER P.C.BOARD	***	1	***																						
24	T/R	***	2	***																											
25	MICA	***	4	***																											
26	BRACKET-RAD(S)	MPAC-16220-004	4	US Co																											
27	RADIATOR	MEAC-08212-004	4	AL																											

EXPLODED VIEW

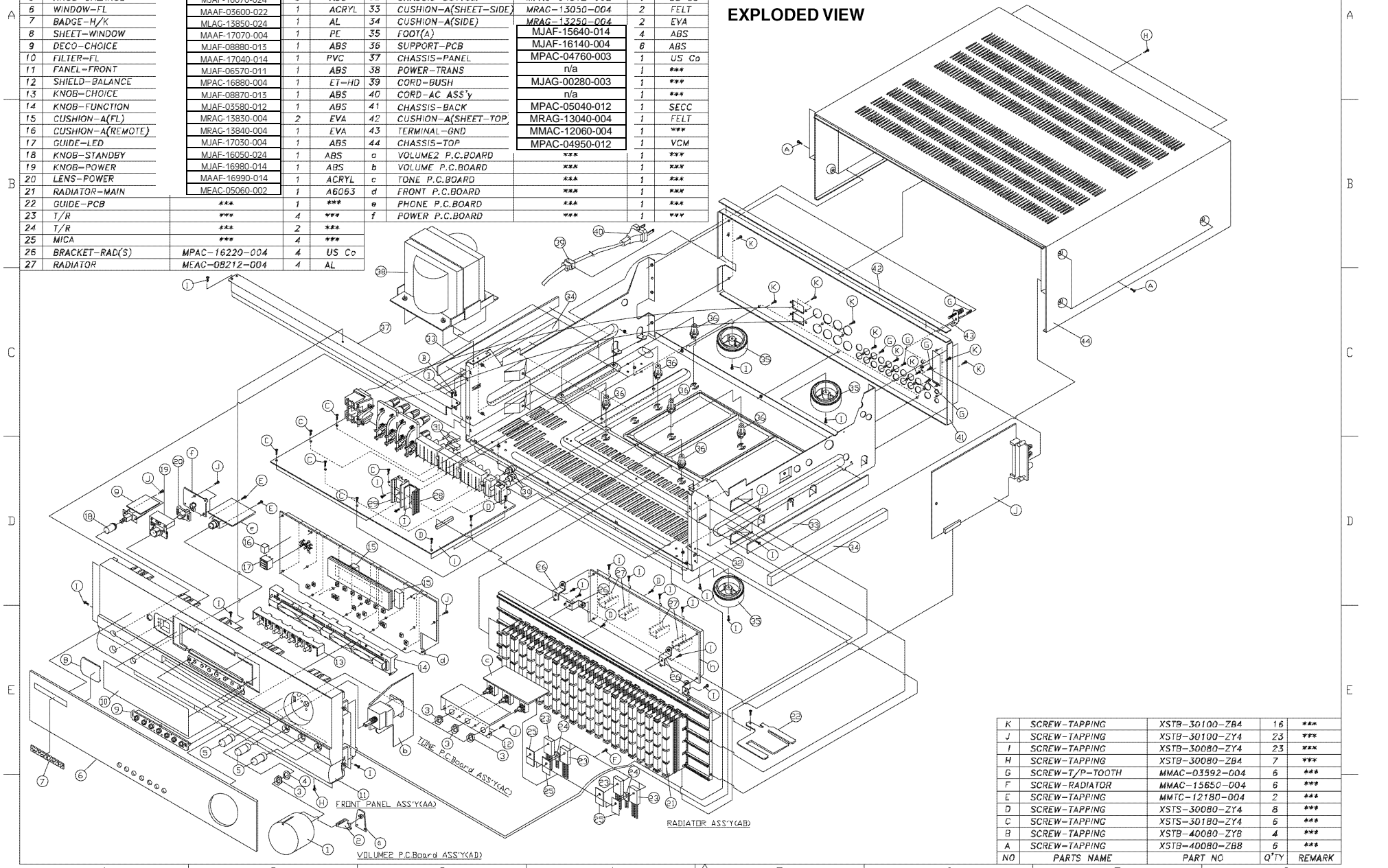

K	SCREW-TAPPING	XSTB-30100-ZB4	16	***
J	SCREW-TAPPING	XSTB-30100-ZY4	23	***
I	SCREW-TAPPING	XSTB-30080-ZY4	23	***
H	SCREW-TAPPING	XSTB-30080-ZB4	7	***
G	SCREW-T/P-TOOTH	MMAC-03592-004	6	***
F	SCREW-RADIATOR	MMAC-15650-004	6	***
E	SCREW-TAPPING	MMTC-12180-004	2	***
D	SCREW-TAPPING	XSTS-30080-ZY4	8	***
C	SCREW-TAPPING	XSTS-30180-ZY4	6	***
B	SCREW-TAPPING	XSTB-40080-ZYB	4	***
A	SCREW-TAPPING	XSTB-40080-ZBB	6	***
NO	PARTS NAME	PART NO	Q'TY	REMARK

## 5. DISASSEMBLY PROCEDURES

### <1> CHASSIS-TOP(44) REMOVAL.

Remove 9 screws(A,K) and then remove the Chassis-top(44).

### <2> FRONT PANEL ASS'Y(AA) REMOVAL.

1. Remove the Chassis-top(44), referring to the previous step <1>.
2. Disconnect the connector(CN 301, Card-cable) on the Front P. C. Board(d) from connector(CN 115) on the Main P. C. Board (i).
3. Disconnect the lead wire(CW 302, 5P) on the Front P. C. Board(d) from connector(CN 702) on the Volume P. C. Board (b).
4. Disconnect the connector(CN 801, 2P) on the Standby P. C. Board(g) from connector(CN 102) on the Main P. C. Board (i).
5. Remove 1 screw(l) of Chassis-panel(37) and then lead wire(H 801, 1P) on the Phones P. C. Board(e).
6. Disconnect the lead wire(CW 301, 7p) on the Front P. C. Board(d) from connector(CN 113) on the Main P. C. Board(i).
7. Disconnect the lead wire(CW 801, 3P) on the Phones P. C. Board(e) from connector(CN 401) on the Amp P. C. Board(h).
8. Remove 1 screw(l) of Chassis-panel(37) and then lead wire(H 501, 1P) on the Tone P. C. Board (c).
9. Disconnect the lead wire(CW 701, 10P) on the Volume P. C. Board(b) from connector (CN 109) on the Main P. C. Board(i).
10. Remove 9 screws(H, I) and then remove the Front Panel ASS'Y(AA).

### <3> FRONT P. C. BOARD(d) REMOVAL.

1. Remove the Chassis-top(44), referring to the previous step<1>.
2. Remove the Front-panel ASS'Y(AA), referring to the previous step<2>.
3. Disconnect the lead wire(CW 302, 5P) from connector(CN 702) on the Volume P. C. Board(b).
4. Disconnect the connector(CN 302) from lead wire(CW 801,5P) on the Power P.C.Board (f).
5. Remove 15 screws(J) and then remove the Front P.C.Board(d).

### <4> VOLUME P.C.BOARD(b) REMOVAL.

1. Remove the Chassis-top(44), referring to the previous step<1>.
2. Remove the Front-panel ASS'Y(AA), referring to the previous step<2>.
3. Disconnect the connector(CN 702) from lead wire(CW 302, 5P) on the Front P. C. Board(d).
4. Disconnect the connector(CN 703) from lead wire(CW 802, 2P) on the Volume2 P. C. Board(a).
5. Disconnect the connector(CN 701) from lead wire(CW 501, 10P) on the Tone P. C. Board(c).
6. Disconnect the lead wire(CW 701,10P) from connector(CN 109) on the Main P. C. Board(i).
7. Full out the Volume Knob(1).
8. Remove 1 hexagon nut(3), 1 washer(4) and then remove the Volume P. C. Board(b).

### <5> VOLUME2 P. C. BOARD(a) ASS'Y(AD) REMOVAL.

1. Remove the Chassis-top(44), referring to the previous step<1>.
2. Remove the Front-panel ASS'Y(AA), referring to the previous step<2>.
3. Disconnect the lead wire(CW 802, 2P) from connector(CN 703) on the Volume P.C.Board(b).
4. Full out the Volume Knob(1).

### <6> VOLUME2 P. C. BOARD(a) REMOVAL.

1. Remove the Chassis-top(44), referring to the previous step<1>.
2. Remove the Front-panel ASS'Y(AA), referring to the previous step<2>.
3. Remove the Volume P. C. Board(b) ASS'Y(AD), referring to the previous step<5>.
4. Full out the Volume2 P. C. Board(a).

### <7> TONE P. C. BOARD(c) REMOVAL.

1. Remove the Chassis-top(44), referring to the previous step<1>.
2. Remove the Front-panel ASS'Y(AA), referring to the previous step<2>.
3. Disconnect the lead wire(CW 501, 10P) from connector(CN 701) on the Volume P. C. Board(b).
4. Pull out the Balance-knob(5).
5. Remove 4 screws(J) and then remove the Tone P. C. Board ASS'Y(AC).
6. Remove 4 hexagon nut(3) and then remove the Shield-balance(12).

## &lt;8&gt; PHONES P. C. BOARD(e) REMOVAL.

1. Remove the Chassis-top(44), referring to the previous step<1>.
2. Remove the Front-panel ASS'Y(AA), referring to the previous step<2>.
3. Disconnect the lead wire(CW 801, 3P) from connector(CN 401) on the Amp P. C. Board(h).
4. Remove 2 screws(E) and then remove the Phones P. C. Board(e).

## &lt;9&gt; POWER P. C. BOARD(f) REMOVAL.

1. Remove the Chassis-top(44), referring to the previous step<1>.
2. Remove the Front-panel ASS'Y(AA), referring to the previous step<2>.
3. Disconnect the lead wire(CW 801, 5P) from connector(CN 302) on the Front P. C. Board(d).
4. Remove 2 screws(J) and then remove the Power P. C. Board(f).

## &lt;10&gt; STANDBY P. C. BOARD(g) REMOVAL.

1. Remove the Chassis-top(44), referring to the previous step<1>.
2. Remove the Front-panel ASS'Y(AA), referring to the previous step<2>.
3. Remove 2 screws(J) and then remove the Standby P. C. Board(g).

## &lt;11&gt; TUNER P. C. BOARD(j) REMOVAL.

1. Remove the Chassis-top(44), referring to the previous step<1>.
2. Remove 21 screws(G,K) and then remove the Chassis-back(41).
3. Pull out the Tuner P. C. Board(j).

## &lt;12&gt; RADIATOR ASS'Y(AB) REMOVAL.

1. Remove the Chassis-top(44), referring to the previous step<1>.
2. Disconnect the connector(CN 401) from lead wire(CW 801, 3P) on the Phones P. C. Board(e).
3. Disconnect the lead wire(CW 403, 4P) from connector(CN 111, CN 112) on the Main P. C. Board(i).
4. Disconnect the lead wire(CW 402, 10P) from connector(CN 107) on the Main P. C. Board(i).
5. Disconnect the lead wire(CW 401, 4P) from connector(CN 108) on the Main P. C. Board(i).
6. Remove 7 screws(l) and then pull out the Radiator Ass'Y(AB).

## &lt;13&gt; AMP P. C. BOARD(h) REMOVAL.

1. Remove the Chassis-top(44), referring to the previous step<1>.
2. Remove the Radiator Ass'Y(AB), referring to the Previous step<12>.
3. Disconnect the connector(CN 402) from lead wire(posistor, 2P) on the Radiator-main (21).
4. Remove 4 screws(D) and then remove the Amp P. C. Board(h).

## &lt;14&gt; POWER TRANS(38) REMOVAL.

1. Remove the Chassis-top(44), referring to the previous step<1>.
2. Disconnect the lead wire(2P) from connector(CN 103) on the Main P. C. Board(i).
3. Disconnect the lead wire(3P) from connector(CN 104) on the Main P. C. Board(i).
4. Disconnect the lead wire(6P) from connector(CN 105) on the Main P. C. Board(i).
5. Disconnect the lead wire(3P) from connector(CN 106) on the Main P. C. Board(i).
6. Remove 4 screws(B) and then remove the Power trans(38).

## &lt;15&gt; MAIN P. C. BOARD(i) REMOVAL.

1. Remove the Chassis-top(44), referring to the previous step<1>.
2. Remove the Tuner P. C. Board(j), referring to the previous step<11>.
3. Disconnect the connector(CN 109) from lead wire(CW 701, 10P) on the Volume P. C. Board(b).
4. Disconnect the connector(CN 108) from lead wire(CW 401, 4P) on the Amp P. C. Board(h).
5. Disconnect the connector(CN 115) from connector(CN 301, card cable) on the Front P. C. Board(d).
6. Disconnect the connector(CN 107) from lead wire(CW 402, 10P) on the Amp P. C. Board(h).
7. Disconnect the connector(CN 106) from lead wire(3P) on the Power-trans(38).
8. Disconnect the connector(CN 105) from lead wire(6P) on the Power-trans(38).
9. Disconnect the connector(CN 113) from lead wire(CW 301, 7P) on the Front P. C. Board(d).
10. Disconnect the connector(CN 104) from lead wire(3P) on the Power-trans(38).
11. Disconnect the connector(CN 111, CN 112) from lead wire(CW 403, 4P) on the Amp P. C. Board(h).
12. Disconnect the connector(CN 102) from lead wire(CN 801, 2P) on the Standby P. C. Board(g).
13. Disconnect the connector(CN 103) from lead wire(2P) on the Power-trans(38).
14. Disconnect the connector(CN 101) from Ac cord(40).

1. Removing the Chassis Top  
Remove the screws ①-⑨

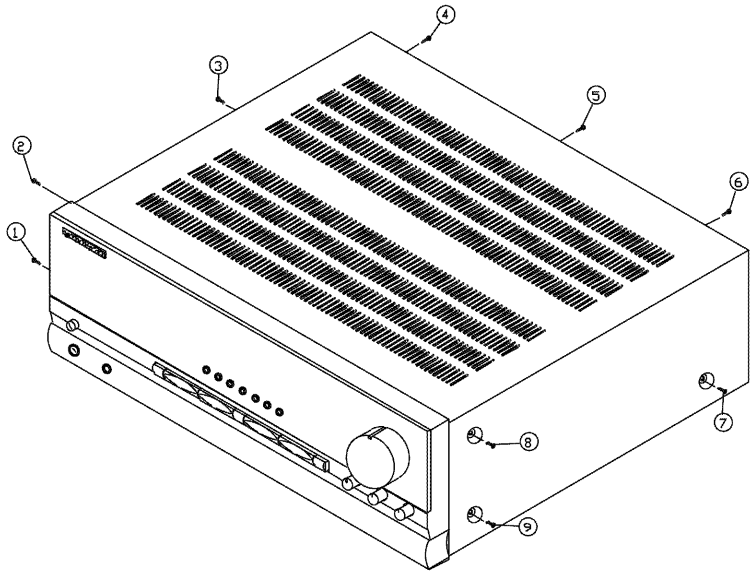

2. Removing the Front Panel  
Remove the screws ①-⑥

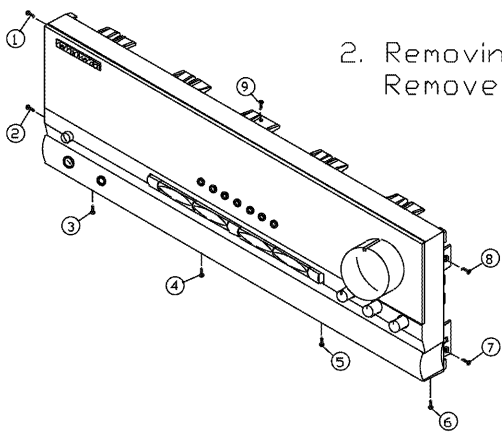

3. Removing the Rear Panel  
Remove the screws ①-⑳

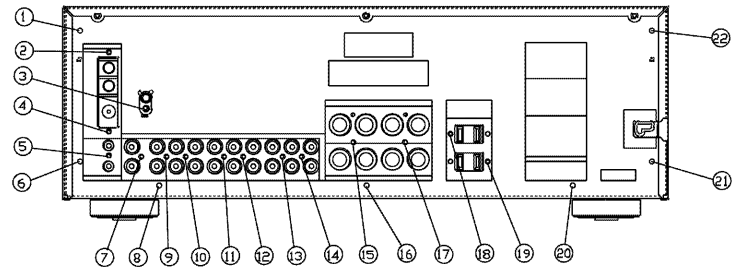

4. Removing the Main PCB Block  
Remove the screws ①-⑨

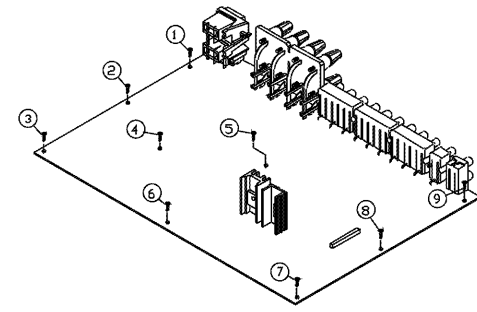

1. Removing the Chassis Top  
Remove the screws ①-⑨

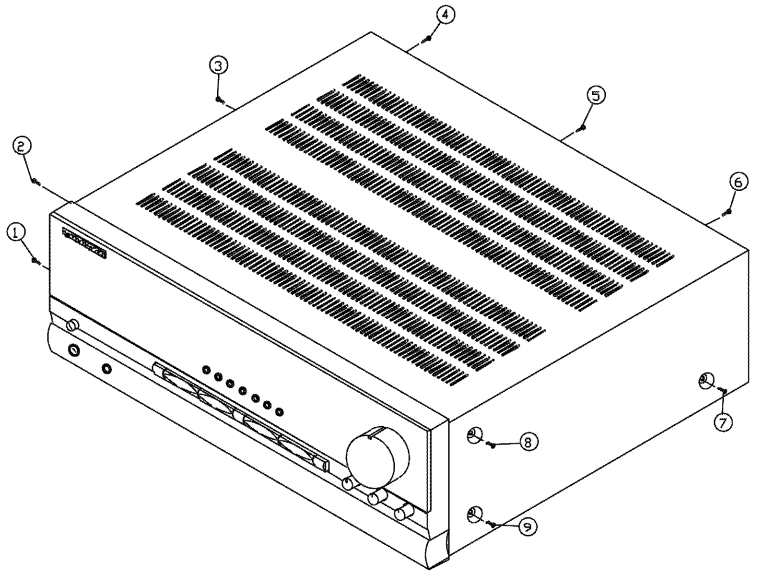

2. Removing the Front Panel  
Remove the screws ①-⑥

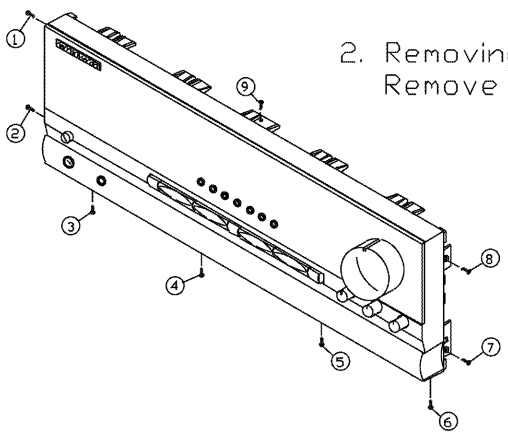

3. Removing the Rear Panel  
Remove the screws ①-⑳

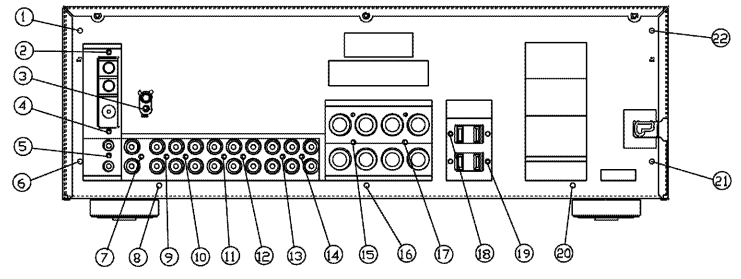

4. Removing the Main PCB Block  
Remove the screws ①-⑨

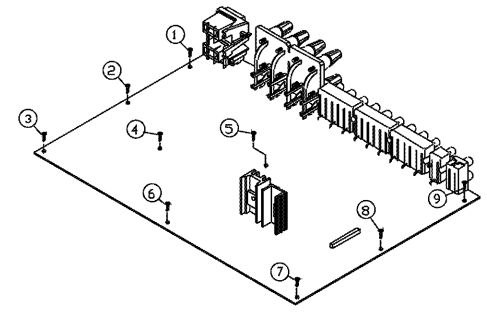

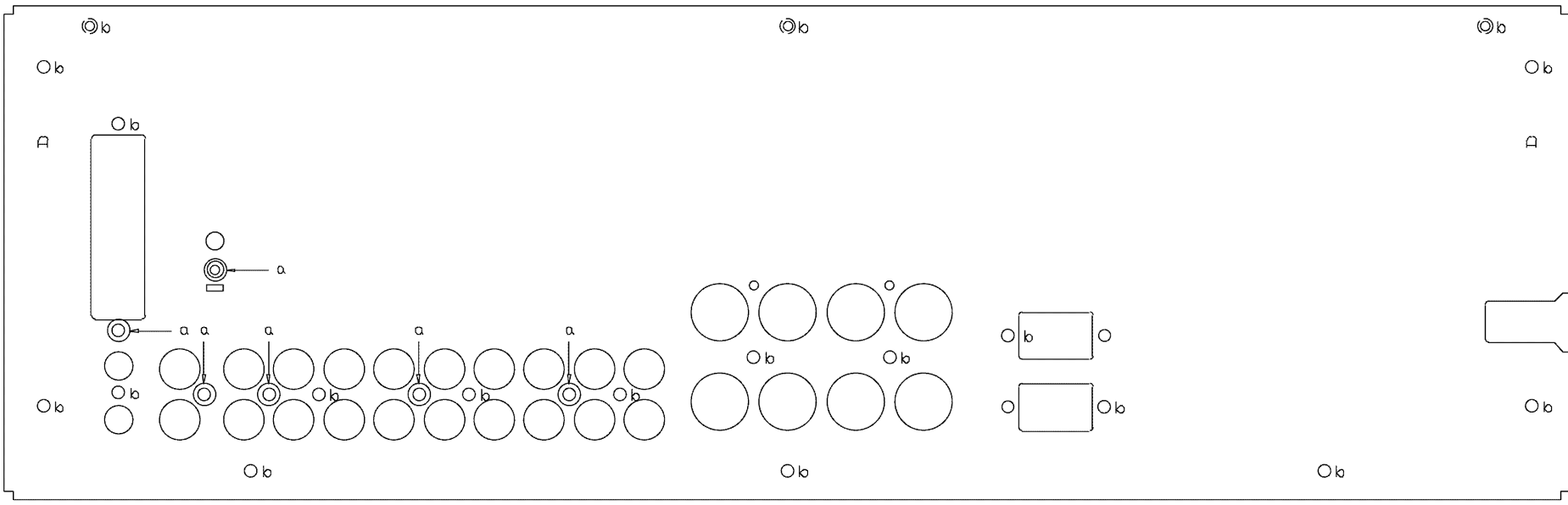

- \* a POINT(6) : MMAC-16400-004 SCREW-T/P-TOOTH(FOR GROUNDING)
- \* b POINT(19) : XSTB-30100-ZB4 SCREW-TAPPING

MMAC-16400-004 SCREW-T/P-TOOTH

XSTB-30100-ZB4 SCREW-TAPPING

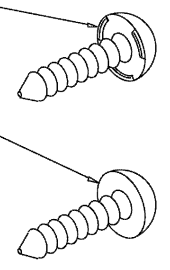

\* HK-3370 : PRINCIPAL SCREW LOCATION

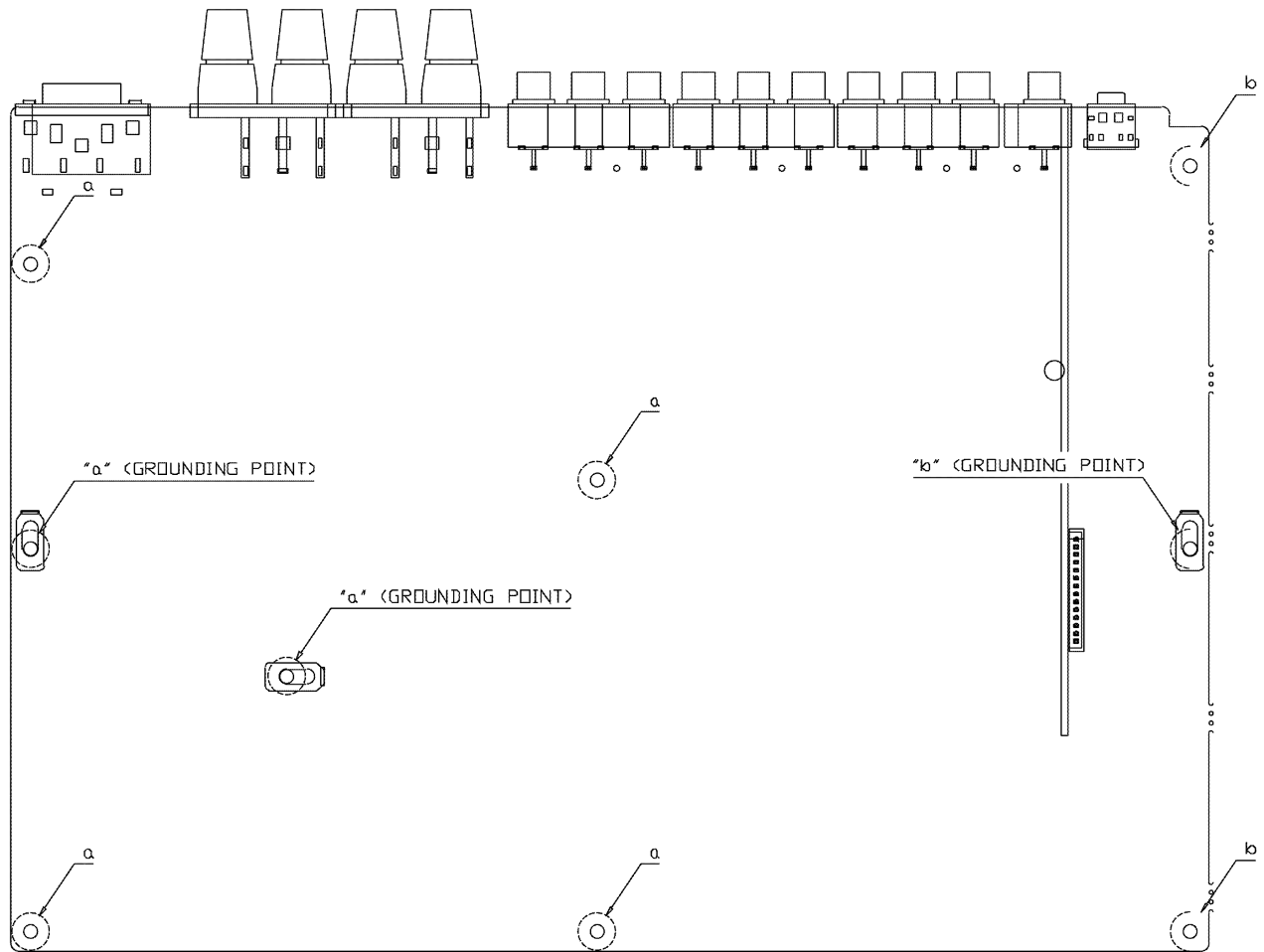

\* a POINT  
 - XSTS-30180-ZY4 SCREW-TAPPING

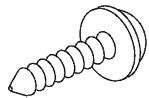

\* b POINT  
 - XSTS-30080-ZY4 SCREW-TAPPING

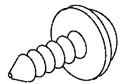

\* a POINT(6) : XSTS-30180-ZY4 SCREW-TAPPING  
 \* b POINT(3) : XSTS-30080-ZY4 SCREW-TAPPING



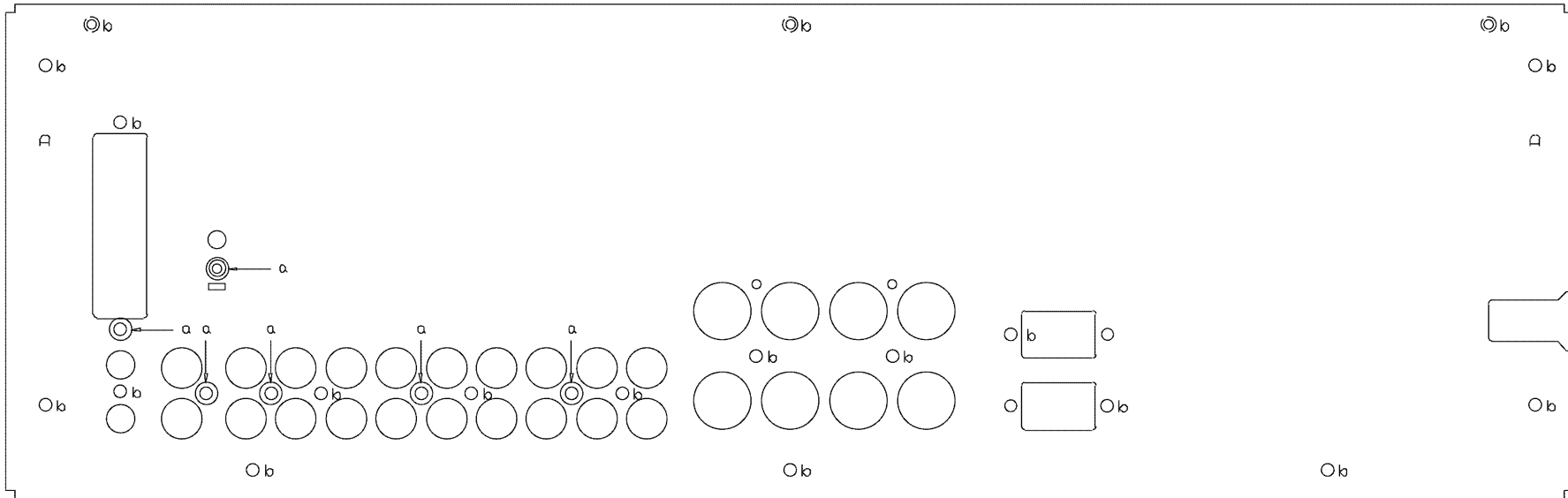

- \* a POINT(6) : MMAC-16400-004 SCREW-T/P-TOOTH(FOR GROUNDING)
- \* b POINT(19) : XSTB-30100-ZB4 SCREW-TAPPING

MMAC-16400-004 SCREW-T/P-TOOTH

XSTB-30100-ZB4 SCREW-TAPPING

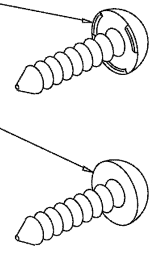

\* HK-3470 : PRINCIPAL SCREW LOCATION

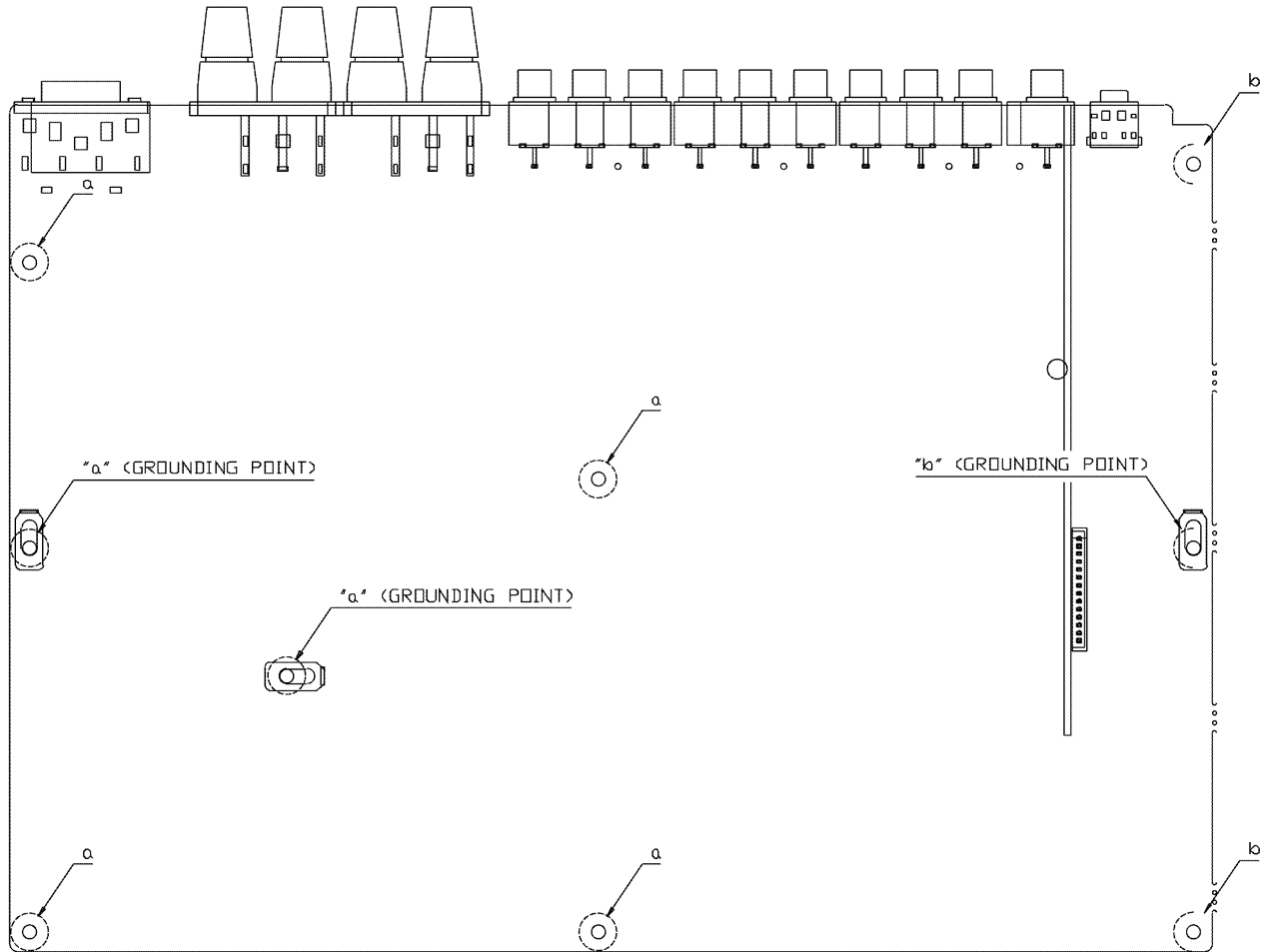

\* a POINT  
- XSTS-30180-ZY4 SCREW-TAPPING

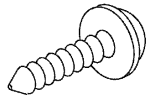

\* b POINT  
- XSTS-30080-ZY4 SCREW-TAPPING

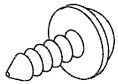

\* a POINT(6) : XSTS-30180-ZY4 SCREW-TAPPING  
\* b POINT(3) : XSTS-30080-ZY4 SCREW-TAPPING

## 8. Part List

Ref. No.	Part No.	Description	
<b>BLOCK SUB</b>			
	ZBNG-00700-4ZL	BOND-ADHESIVE	#575
	ZBNG-01300-5ZL	LOCKER-SCREW	#1401B
#	ZGSI-01000-9PN	GREASE-SILICON	G-746
	ZSBR-00010-060	SOLDER-BAR	SN60
#	ZSWR-00010-F60	SOLDER-WIRE	D1.0 SN60
#	ZTOP-00701-50C	TAPE-OPP	
	ZTWF-01200-039	TAPE-DOUBLE FACE	TESA 4968 W = 3.0 t=0.32
#	ZZFX-00010-000	FLUX	ROSIN 28
	ZZTH-00010-000	DILUENT	ROSIN
<b>BLOCK MECHA</b>			
	ACRC-00670-000	ASS'Y-REMOCON	HK3370RC
	ANTL-00060-E50	ANTENNA-LOOP	AAN-007 19.5uH 7T 125x93
	ANNT-00054-075	ANTENNA-T TYPE	75ohm W/TER(Y)-1200m/m
	BAMN-00010-150	BATTERY MANGANESE	R03(AAAM) 1.5V 10.5x44.5
	FGFB-O2002-831	FUSE GLASS	2A 125V 51S
	FGFB-O3151-831	FUSE GLASS	315mA 125V 5x20 U/C SB
	FGFB-O5002-831	FUSE GLASS	5A 125V 5x20 U/C SB
	KDAC-0575D-H00	CORD-AC	KKP-10W WITH CORE
	LLA3-20401-E10	CARD CABLE	1.25x20Px400xCx(0.1x0.8)
	MAAF-03600-012	WINDOW-FL	HK3370 ACRYL T=3.0 (L
	MAAF-16130-014	LENS-VOLUME	HK3370 PMMA(IF-850)
	MAAF-16990-014	LENS-POWER	HK3370 ACRYL
	MAAF-17040-014	FILTER-FL	HK3370 PVC T0.5
	MAAF-17070-004	SHEET-WINDOW	PE(DRAFTING FILM)
	MEAC-05070-002	RADIATOR-MAIN	A6063 T-5
	MJAF-03580-012	KNOB-FUNCTION	HK3370 ABS
	MJAF-06570-011	PANEL-FRONT	HK3370 ABS
	MJAF-08870-013	KNOB-CHOICE	HK3370 ABS
	MJAF-08880-013	DECO-CHOICE	HK3370 ABS
	MJAF-15640-014	FOOT(A)	AVR200
	MJAF-16050-014	KNOB-STANDBY	AVR200 ABS-720
	MJAF-16070-014	KNOB-BALANCE	AVR200 ABS-720
	MJAF-16100-014	KNOB-VOLUME	HK3370 ABS-720
	MJAF-16140-004	SUPPORT-PCB	ABS-720
	MJAF-16980-014	KNOB-POWER	HK3370 ABS
	MJAF-17030-004	GUIDE-LED	ABS
	MJAG-00280-003	CORD-BUSH	NIFCO
	MJAG-04540-004	CABLE-TIE-L80	*
	MLAG-13850-014	BADGE-H/K	HK3370 AL
	MMAC-12060-004	TERMINAL-GND	
	MMAC-15650-004	SCREW-RADIATOR	
	MMAC-16400-004	SCREW-T/P-TOOTH	3X10 BLACK
	MMAC-17070-004	JACK-CONNECT	
	MMSC-00900-004	AIR-STAPLER	
	MMTC-00751-003	SCREW-TAPPING	BHW T2T 3x8 FE-ZY
	MPAC-04760-003	CHASSIS-PANEL	US Coating t1.0
	MPAC-04812-002	CHASSIS-BOTTOM	US COATING T1.2
	MPAC-04950-012	CHASSIS-TOP	AVR200 SECC(T0.6) + P
	MPAC-05040-012	CHASSIS-BACK	HK3370 SECC T0.8
	MPAC-16220-004	BRACKET-RADIATOR(S)	US COATING T1.0

Ref. No.	Part No.	Description	
<b>BLOCK MECHA</b>			
	MPAC-16880-004	SHIELD-BALANCE	ET-HD T0.5
	MRAG-13040-004	CUSHION-A	FELT 437x10x0.5 S
	MRAG-13050-004	CUSHION-A	FELT 250x10x0.5 S
	MRAG-13250-004	CUSHION-A	EVA T=5.0
	MWAW-00910-003	PALLETS	1040X1126X141
	PLRC-00020-S30	PLUG RCA	SHORT JACK
	PTAN-03790-CJU	POWER TRANSFORMER	A86-379C-U(120V 60Hz)
	TFMA-00100-D00	TRANSFORMER-MATCHING	MT115050 300ohm & 75ohm
Q209	TRSC-01680-SB0	TRANSISTOR N-H FREQ	2SC4137 TO-126FP
Q213	TRSC-01340-SJ0	TRANSISTOR P-H FREQ	2SC3856
Q214	TRSA-00950-SJ0	TRANSISTOR P-H FREQ	2SA-1492
Q224	TRSC-01680-SB0	TRANSISTOR N-H FREQ	2SC4137 TO-126FP
Q228	TRSC-01340-SJ0	TRANSISTOR P-H FREQ	2SC3856
Q229	TRSA-00950-SJ0	TRANSISTOR P-H FREQ	2SA-1492
Q239	TRSC-01680-SB0	TRANSISTOR N-H FREQ	2SC4137 TO-126FP
Q243	TRSC-01340-SJ0	TRANSISTOR P-H FREQ	2SC3856
Q244	TRSA-00950-SJ0	TRANSISTOR P-H FREQ	2SA-1492
Q254	TRSC-01680-SB0	TRANSISTOR N-H FREQ	2SC4137 TO-126FP
Q256	TRSC-01340-SJ0	TRANSISTOR P-H FREQ	2SC3856
Q259	TRSA-00950-SJ0	TRANSISTOR P-H FREQ	2SA-1492
Q269	TRSC-01680-SB0	TRANSISTOR N-H FREQ	2SC4137 TO-126FP
Q273	TRSC-01340-SJ0	TRANSISTOR P-H FREQ	2SC3856
Q274	TRSA-00950-SJ0	TRANSISTOR P-H FREQ	2SA-1492
	U348-9B350-480	WIRE-ASS'Y	1618#18-500 WHT 3P
	VSPO-00010-100	POSISTOR	P42T8D100BW23
	XSTB-30080-ZB4	SCREW-TAPPING	BHT2T 3x8 FE-ZB
	XSTB-30080-ZY4	SCREW-TAPPING	BHT2T 3x8 FE-ZY
	XSTB-30100-ZB4	SCREW-TAPPING	BHT2T 3x10 FE-ZB
	XSTB-30100-ZY4	SCREW-TAPPING	BHT2T 3x10 FE-ZY
	XSTB-40080-ZB8	SCREW-TAPPING	BHT3T 4x8 FE-ZB
	XSTB-40080-ZY8	SCREW-TAPPING	BHT3T 4x8 FE-ZY
	XSTS-30080-ZY4	SCREW-TAPPING	PHWT2T 3x8 FE-ZY
	XSTS-30180-ZY4	SCREW-TAPPING	PHWT2T 3x18 FE-ZY
	YGAP-14860-054	BOX-GIFT	HK3370 535X480X231 DW
	YSAP-12070-002	CUSHION-L/R	EPS
	YVAP-01862-004	POLY-BAG-F	*
	YVAP-13320-004	TOLON-SHEET	750x1200 0.5t
	7JJG-00212-001	PACKING WRAP	500mm*1400m
<b>BLOCK MAIN PCB</b>			
C101	CCAT-J101K-AAB	CAPACITOR CERAMIC	100PF K 50V B T
C102	CCAT-J101K-AAB	CAPACITOR CERAMIC	100PF K 50V B T
C119	CCAT-J101K-AAB	CAPACITOR CERAMIC	100PF K 50V B T
C120	CCAT-J101K-AAB	CAPACITOR CERAMIC	100PF K 50V B T
C134	CCAT-F103Z-AAF	CAPACITOR CERAMIC	0.01uF Z 25V F T
C135	CCAT-J473Z-AAF	CAPACITOR CERAMIC	0.047uF Z 50V F T
C136	CCAT-J473Z-AAF	CAPACITOR CERAMIC	0.047uF Z 50V F T
C137	CCAT-J473Z-AAF	CAPACITOR CERAMIC	0.047uF Z 50V F T
C139	CEET-J4R7M-C10	CAPACITOR E/ALUMINUM	4.7uF M 50V 5x11 T
C140	CEET-J4R7M-C10	CAPACITOR E/ALUMINUM	4.7uF M 50V 5x11 T
C141	CCAT-J102K-AAB	CAPACITOR CERAMIC	1000PF K 50V B T

Ref. No.	Part No.	Description
<b>BLOCK MAIN PCB</b>		
C142	CCAT-J102K-AAB	CAPACITOR CERAMIC 1000PF K 50V B T
C143	CEET-D101M-CIO	CAPACITOR E/ALUMINUM 100uF M 10V 5x11 T
C144	CEET-D101M-CIO	CAPACITOR E/ALUMINUM 100uF M 10V 5x11 T
C145	CFMT-N152J-CJO	CAPACITOR F/POLYESTR 0.0015uF J 100V 5.4x12 T
C146	CFMT-N152J-CJO	CAPACITOR F/POLYESTR 0.0015uF J 100V 5.4x12 T
C147	CFMT-N562J-DJO	CAPACITOR F/POLYESTR 0.0056uF J 100V 5.8x12 T
C148	CFMT-N562J-DJO	CAPACITOR F/POLYESTR 0.0056uF J 100V 5.8x12 T
C149	CEET-J4R7M-CIO	CAPACITOR E/ALUMINUM 4.7uF M 50V 5x11 T
C150	CEET-J4R7M-CIO	CAPACITOR E/ALUMINUM 4.7uF M 50V 5x11 T
C151	CFMT-N182J-CJO	CAPACITOR F/POLYESTR 0.0018uF J 100V 5.5x12 T
C152	CFMT-N182J-CJO	CAPACITOR F/POLYESTR 0.0018uF J 100V 5.5x12 T
C153	CEET-F470M-CIO	CAPACITOR E/ALUMINUM 47uF M 25V 5x11 T
C154	CEET-F470M-CIO	CAPACITOR E/ALUMINUM 47uF M 25V 5x11 T
C155	CEET-F470M-CIO	CAPACITOR E/ALUMINUM 47uF M 25V 5x11 T
C156	CEET-F470M-CIO	CAPACITOR E/ALUMINUM 47uF M 25V 5x11 T
C157	CEET-J1R0M-CIO	CAPACITOR E/ALUMINUM 1.0uF M 50V 5x11 T
C158	CCAT-J101K-AAB	CAPACITOR CERAMIC 100PF K 50V B T
C159	CEET-J4R7M-CIO	CAPACITOR E/ALUMINUM 4.7uF M 50V 5x11 T
C160	CEET-J4R7M-CIO	CAPACITOR E/ALUMINUM 4.7uF M 50V 5x11 T
C161	CEET-F470M-CIO	CAPACITOR E/ALUMINUM 47uF M 25V 5x11 T
C162	CEET-F470M-CIO	CAPACITOR E/ALUMINUM 47uF M 25V 5x11 T
C163	CEET-F470M-CIO	CAPACITOR E/ALUMINUM 47uF M 25V 5x11 T
C164	CEET-F470M-CIO	CAPACITOR E/ALUMINUM 47uF M 25V 5x11 T
C173	CEET-J4R7M-CIO	CAPACITOR E/ALUMINUM 4.7uF M 50V 5x11 T
C174	CEET-J4R7M-CIO	CAPACITOR E/ALUMINUM 4.7uF M 50V 5x11 T
C175	CCAT-J102K-AAB	CAPACITOR CERAMIC 1000PF K 50V B T
C176	CCAT-J102K-AAB	CAPACITOR CERAMIC 1000PF K 50V B T
C177	CEET-J4R7M-CIO	CAPACITOR E/ALUMINUM 4.7uF M 50V 5x11 T
C178	CEET-J4R7M-CIO	CAPACITOR E/ALUMINUM 4.7uF M 50V 5x11 T
C179	CEET-F470M-CIO	CAPACITOR E/ALUMINUM 47uF M 25V 5x11 T
C180	CEET-F470M-CIO	CAPACITOR E/ALUMINUM 47uF M 25V 5x11 T
C183	CEET-J1R0M-CIO	CAPACITOR E/ALUMINUM 1.0uF M 50V 5x11 T
C184	CACS-S472M-179	CAPACITOR AC DE7100F472M
C185	CFMT-N473J-GKO	CAPACITOR F/POLYESTR 0.047uF J 100V 8.9x13. T
C186	CFMT-N473J-GKO	CAPACITOR F/POLYESTR 0.047uF J 100V 8.9x13. T
C187	CFMT-N473J-GKO	CAPACITOR F/POLYESTR 0.047uF J 100V 8.9x13. T
C188	CEET-F102M-HNO	CAPACITOR E/ALUMINUM 1000uF M 25V 13x16 T
C189	CEET-J1R0M-CIO	CAPACITOR E/ALUMINUM 1.0uF M 50V 5x11 T
C190	CCAT-J104Z-AAF	CAPACITOR CERAMIC 0.1uF Z 50V F T
C191	CCAT-F223Z-AAF	CAPACITOR CERAMIC 0.022uF Z 25V F T
C192	CCAT-F223Z-AAF	CAPACITOR CERAMIC 0.022uF Z 25V F T
C194	CEET-J470M-DIO	CAPACITOR E/ALUMINUM 47uF M 50V 6.3x11 T
C195	CEET-J470M-DIO	CAPACITOR E/ALUMINUM 47uF M 50V 6.3x11 T
C196	CCCT-J104Z-OFF	CAPACITOR CERAMIC 0.1uF Z 50V F T
C197	CFMT-N103J-DEO	CAPACITOR F/POLYESTR 0.01uF J 100V 6x7 T
C198	CFMT-N103J-DEO	CAPACITOR F/POLYESTR 0.01uF J 100V 6x7 T
C199	CFMT-N103J-DEO	CAPACITOR F/POLYESTR 0.01uF J 100V 6x7 T
C200	CEET-E471M-FI1	CAPACITOR E/ALUMINUM 470uF M 16V 8x11.5 U T
C201	CEET-J1R0M-CIO	CAPACITOR E/ALUMINUM 1.0uF M 50V 5x11 T
C202	CCAT-J104Z-AAF	CAPACITOR CERAMIC 0.1uF Z 50V F T
C203	CFMT-N103J-DEO	CAPACITOR F/POLYESTR 0.01uF J 100V 6x7 T

Ref. No.	Part No.	Description
<b>BLOCK MAIN PCB</b>		
C204	CFMT-N103J-DE0	CAPACITOR F/POLYESTR 0.01uF J 100V 6x7 T
C205	CFMT-N103J-DE0	CAPACITOR F/POLYESTR 0.01uF J 100V 6x7 T
C206	CEEM-G222M-LR1	CAPACITOR E/ALUMINUM 2200uF M 35V 16x31.5 U M
C207	CEEM-G222M-LR1	CAPACITOR E/ALUMINUM 2200uF M 35V 16x31.5 U M
C208	CEET-J1R0M-C10	CAPACITOR E/ALUMINUM 1.0uF M 50V 5x11 T
C209	CEET-J1R0M-C10	CAPACITOR E/ALUMINUM 1.0uF M 50V 5x11 T
C210	CEET-G221M-HJ1	CAPACITOR E/ALUMINUM 220uF M 35V 10x12.5 U T
C211	CFMT-S104K-G10	CAPACITOR F/POLYESTR 0.1uF K 250V 9.5x11 TL
C212	CFMT-S104K-G10	CAPACITOR F/POLYESTR 0.1uF K 250V 9.5x11 TL
C213	CFMT-S104K-G10	CAPACITOR F/POLYESTR 0.1uF K 250V 9.5x11 TL
C214	CFMT-S104K-G10	CAPACITOR F/POLYESTR 0.1uF K 250V 9.5x11 TL
C215	CFMT-S104K-G10	CAPACITOR F/POLYESTR 0.1uF K 250V 9.5x11 TL
C216	CEEZ-L104M-SV3	CAPACITOR E/ALUMINUM 10000uF M 63V 35x50 SMH
C217	CEEZ-L104M-SV3	CAPACITOR E/ALUMINUM 10000uF M 63V 35x50 SMH
C218	CEET-J1R0M-C10	CAPACITOR E/ALUMINUM 1.0uF M 50V 5x11 T
C219	CEET-J1R0M-C10	CAPACITOR E/ALUMINUM 1.0uF M 50V 5x11 T
C220	CFMT-N473J-GK0	CAPACITOR F/POLYESTR 0.047uF J 100V 8.9x13. T
C221	CFMT-N473J-GK0	CAPACITOR F/POLYESTR 0.047uF J 100V 8.9x13. T
C222	CFMT-N473J-GK0	CAPACITOR F/POLYESTR 0.047uF J 100V 8.9x13. T
C223	CFMT-N473J-GK0	CAPACITOR F/POLYESTR 0.047uF J 100V 8.9x13. T
	CEET-F220M-C10	CAPACITOR E/ALUMINUM 22uF M 25V 5x11 T
D101	DDMR-00230-T10	DIODE-RECTIFIER GP60-04F(400V 6A)
D102	DDMR-00230-T10	DIODE-RECTIFIER GP60-04F(400V 6A)
D103	DDMR-00230-T10	DIODE-RECTIFIER GP60-04F(400V 6A)
D104	DDMR-00230-T10	DIODE-RECTIFIER GP60-04F(400V 6A)
D105	DDTR-00040-T10	DIODE-RECTIFIER 1N4004S(400V 1A 0.6mm) T
D106	DDTR-00040-T10	DIODE-RECTIFIER 1N4004S(400V 1A 0.6mm) T
D107	DDTR-00040-T10	DIODE-RECTIFIER 1N4004S(400V 1A 0.6mm) T
D108	DDTR-00040-T10	DIODE-RECTIFIER 1N4004S(400V 1A 0.6mm) T
D109	DDTR-00040-T10	DIODE-RECTIFIER 1N4004S(400V 1A 0.6mm) T
D110	DDTR-00040-T10	DIODE-RECTIFIER 1N4004S(400V 1A 0.6mm) T
D113	DDTR-00040-T10	DIODE-RECTIFIER 1N4004S(400V 1A 0.6mm) T
D114	DDTR-00040-T10	DIODE-RECTIFIER 1N4004S(400V 1A 0.6mm) T
D115	DDTR-00040-T10	DIODE-RECTIFIER 1N4004S(400V 1A 0.6mm) T
D116	DDTR-00040-T10	DIODE-RECTIFIER 1N4004S(400V 1A 0.6mm) T
D117	DDTR-00040-T10	DIODE-RECTIFIER 1N4004S(400V 1A 0.6mm) T
D118	DDTR-00040-T10	DIODE-RECTIFIER 1N4004S(400V 1A 0.6mm) T
D119	DDTR-00040-T10	DIODE-RECTIFIER 1N4004S(400V 1A 0.6mm) T
D120	DDTR-00040-T10	DIODE-RECTIFIER 1N4004S(400V 1A 0.6mm) T
D121	DDTR-00040-T10	DIODE-RECTIFIER 1N4004S(400V 1A 0.6mm) T
D122	DDTR-00040-T10	DIODE-RECTIFIER 1N4004S(400V 1A 0.6mm) T
D125	DDTR-00040-T10	DIODE-RECTIFIER 1N4004S(400V 1A 0.6mm) T
D126	DDTR-00040-T10	DIODE-RECTIFIER 1N4004S(400V 1A 0.6mm) T
D124	DDTS-00070-SO0	DIODE-SI 1SS133 (40V 0.11A) DO-40 T
D111	DDTZ-G150C-SO0	DIODE ZENER MTZ15C 14.35-15.09 DO40 T
D112	DDTZ-G180C-SO0	DIODE ZENER MTZ18C 17.42-18.33 DO40 T
RL101	ESRY-00340-112	RELAY SDT-S-112DMR
RL102	ESRY-00370-24U	RELAY OSA-SS-224DM3(24V DC)
RL103	ESRY-00370-24U	RELAY OSA-SS-224DM3(24V DC)
IC102	ICDG-00260-S10	IC FUNCTION SELECTOR LC7821 DIP30S
IC107	ICOP-00131-SE0	IC DUAL OP AMP KA4558C DIP8

Ref. No.	Part No.	Description	
<b>BLOCK MAIN PCB</b>			
IC101	ICOP-00432-SG0	IC OP AMP	NJM2068DD DIP8
IC103	ICOP-00432-SG0	IC OP AMP	NJM2068DD DIP8
IC108	ICPC-00010-TB0	IC PHOTOCOUPLER	LTV817B DIP4
IC109	ICRG-00043-SE0	IC REGULATOR	KA7805 5V 3mm TO-220
IC110	ICRG-00043-SE0	IC REGULATOR	KA7805 5V 3mm TO-220
IC111	ICRG-00061-SE0	IC REGULATOR	KA7815 15V 3mm TO-220
IC112	ICRG-00251-SE0	IC REGULATOR	KA7915 15V 3mm TO-220
L101	KIOT-4470K-003	COIL-INDUCTOR	47uH K LAL02 T
L102	KIOT-4470K-003	COIL-INDUCTOR	47uH K LAL02 T
CN107	KNCW-00140-ATM	CONNECTOR-WAFER	5267-10A 2.5mm MILK
CN106	KNCW-00140-3TM	CONNECTOR-WAFER	5267-03A 2.5mm MILK
CN105	KNCW-00140-6TM	CONNECTOR-WAFER	5267-06A 2.5mm MILK
CN113	KNCW-00140-7TM	CONNECTOR-WAFER	5267-07A 2.5mm MILK
CN109	KNCW-00240-AT9	CONNECTOR-WAFER	53014-10 2.0mm WHT
CN108	KNCW-00240-4T9	CONNECTOR-WAFER	53014-04 2.0mm WHT
CN115	KNCW-00823-KT9	CONNECTOR WAFER	6216-20PST
CN111	KNCW-00970-2T9	CONNECTOR-WAFER	JE202-1T-2P
CN112	KNCW-00970-2T9	CONNECTOR-WAFER	JE202-1T-2P
CN104	KNCW-00970-3T9	CONNECTOR-WAFER	JE202-1T-3P
CN101	KNCW-00990-2T9	CONNECTOR-WAFER	JE202A-1T-02
CN102	KNCW-00990-2T9	CONNECTOR-WAFER	JE202A-1T-02
CN103	KNCW-00990-2T9	CONNECTOR-WAFER	JE202A-1T-02
CN114	KNCW-01520-ES9	CONNECTOR-WAFER	35336-1410 20MM 14P
	MEAC-08215-004	RADIATOR-TR	
	MEAC-12693-004	HEAT-SINK(TR)	
GT101	MPAC-03810-004	TERMINAL-GND	ET-HD T0.3
GT102	MPAC-03810-004	TERMINAL-GND	ET-HD T0.3
GT103	MPAC-03810-004	TERMINAL-GND	ET-HD T0.3
FC101	MPAC-11620-004	FUSE CLIP	5.2Pi TAPPING TYPE
FC102	MPAC-11620-004	FUSE CLIP	5.2Pi TAPPING TYPE
FC103	MPAC-11620-004	FUSE CLIP	5.2Pi TAPPING TYPE
FC104	MPAC-11620-004	FUSE CLIP	5.2Pi TAPPING TYPE
FC107	MPAC-11620-004	FUSE CLIP	5.2Pi TAPPING TYPE
FC108	MPAC-11620-004	FUSE CLIP	5.2Pi TAPPING TYPE
FC109	MPAC-11620-004	FUSE CLIP	5.2Pi TAPPING TYPE
FC110	MPAC-11620-004	FUSE CLIP	5.2Pi TAPPING TYPE
FC111	MPAC-11620-004	FUSE CLIP	5.2Pi TAPPING TYPE
FC112	MPAC-11620-004	FUSE CLIP	5.2Pi TAPPING TYPE
PCB1	PCSR-05390-11B	PCB-SINGLE	A1R-539 330x247x1.6t
PT101	PTA1-03680-CJU	TRANSFORMER-POWER	A28-368C-U
R226	RCFT-E101J-000	RESISTOR-CARBON FILM	100ohm 1/5W 5% T
R101	RCFT-E102J-000	RESISTOR-CARBON FILM	1Kohm 1/5W 5% T
R102	RCFT-E102J-000	RESISTOR-CARBON FILM	1Kohm 1/5W 5% T
R138	RCFT-E102J-000	RESISTOR-CARBON FILM	1Kohm 1/5W 5% T
R139	RCFT-E102J-000	RESISTOR-CARBON FILM	1Kohm 1/5W 5% T
R140	RCFT-E102J-000	RESISTOR-CARBON FILM	1Kohm 1/5W 5% T
R153	RCFT-E102J-000	RESISTOR-CARBON FILM	1Kohm 1/5W 5% T
R154	RCFT-E102J-000	RESISTOR-CARBON FILM	1Kohm 1/5W 5% T
R240	RCFT-E102J-000	RESISTOR-CARBON FILM	1Kohm 1/5W 5% T
R239	RCFT-E103J-000	RESISTOR-CARBON FILM	10Kohm 1/5W 5% T
R119	RCFT-E104J-000	RESISTOR-CARBON FILM	100Kohm 1/5W 5% T

Ref. No.	Part No.	Description
<b>BLOCK MAIN PCB</b>		
R120	RCFT-E104J-000	RESISTOR-CARBON FILM 100Kohm 1/5W 5% T
R121	RCFT-E104J-000	RESISTOR-CARBON FILM 100Kohm 1/5W 5% T
R122	RCFT-E104J-000	RESISTOR-CARBON FILM 100Kohm 1/5W 5% T
R131	RCFT-E104J-000	RESISTOR-CARBON FILM 100Kohm 1/5W 5% T
R132	RCFT-E104J-000	RESISTOR-CARBON FILM 100Kohm 1/5W 5% T
R137	RCFT-E104J-000	RESISTOR-CARBON FILM 100Kohm 1/5W 5% T
R145	RCFT-E104J-000	RESISTOR-CARBON FILM 100Kohm 1/5W 5% T
R146	RCFT-E104J-000	RESISTOR-CARBON FILM 100Kohm 1/5W 5% T
R203	RCFT-E104J-000	RESISTOR-CARBON FILM 100Kohm 1/5W 5% T
R204	RCFT-E104J-000	RESISTOR-CARBON FILM 100Kohm 1/5W 5% T
R207	RCFT-E104J-000	RESISTOR-CARBON FILM 100Kohm 1/5W 5% T
R208	RCFT-E104J-000	RESISTOR-CARBON FILM 100Kohm 1/5W 5% T
R213	RCFT-E104J-000	RESISTOR-CARBON FILM 100Kohm 1/5W 5% T
R214	RCFT-E104J-000	RESISTOR-CARBON FILM 100Kohm 1/5W 5% T
R221	RCFT-E123J-000	RESISTOR-CARBON FILM 12Kohm 1/5W 5% T
R215	RCFT-E152J-000	RESISTOR-CARBON FILM 1.5Kohm 1/5W 5% T
R216	RCFT-E152J-000	RESISTOR-CARBON FILM 1.5Kohm 1/5W 5% T
R209	RCFT-E202J-000	RESISTOR-CARBON FILM 2Kohm 1/5W 5% T
R210	RCFT-E202J-000	RESISTOR-CARBON FILM 2Kohm 1/5W 5% T
R115	RCFT-E221J-000	RESISTOR-CARBON FILM 220ohm 1/5W 5% T
R116	RCFT-E221J-000	RESISTOR-CARBON FILM 220ohm 1/5W 5% T
R117	RCFT-E221J-000	RESISTOR-CARBON FILM 220ohm 1/5W 5% T
R118	RCFT-E221J-000	RESISTOR-CARBON FILM 220ohm 1/5W 5% T
R133	RCFT-E221J-000	RESISTOR-CARBON FILM 220ohm 1/5W 5% T
R134	RCFT-E221J-000	RESISTOR-CARBON FILM 220ohm 1/5W 5% T
R135	RCFT-E221J-000	RESISTOR-CARBON FILM 220ohm 1/5W 5% T
R136	RCFT-E221J-000	RESISTOR-CARBON FILM 220ohm 1/5W 5% T
R155	RCFT-E221J-000	RESISTOR-CARBON FILM 220ohm 1/5W 5% T
R156	RCFT-E221J-000	RESISTOR-CARBON FILM 220ohm 1/5W 5% T
R217	RCFT-E221J-000	RESISTOR-CARBON FILM 220ohm 1/5W 5% T
R218	RCFT-E221J-000	RESISTOR-CARBON FILM 220ohm 1/5W 5% T
R211	RCFT-E222J-000	RESISTOR-CARBON FILM 2.2Kohm 1/5W 5% T
R212	RCFT-E222J-000	RESISTOR-CARBON FILM 2.2Kohm 1/5W 5% T
R230	RCFT-E222J-000	RESISTOR-CARBON FILM 2.2Kohm 1/5W 5% T
R232	RCFT-E222J-000	RESISTOR-CARBON FILM 2.2Kohm 1/5W 5% T
R243	RCFT-E222J-000	RESISTOR-CARBON FILM 2.2Kohm 1/5W 5% T
R244	RCFT-E222J-000	RESISTOR-CARBON FILM 2.2Kohm 1/5W 5% T
R151	RCFT-E224J-000	RESISTOR-CARBON FILM 220Kohm 1/5W 5% T
R152	RCFT-E224J-000	RESISTOR-CARBON FILM 220Kohm 1/5W 5% T
R225	RCFT-E271J-000	RESISTOR-CARBON FILM 270ohm 1/5W 5% T
R235	RCFT-E3R3J-000	RESISTOR-CARBON FILM 3.3ohm 1/5W 5% T
R236	RCFT-E3R3J-000	RESISTOR-CARBON FILM 3.3ohm 1/5W 5% T
R222	RCFT-E332J-000	RESISTOR-CARBON FILM 3.3Kohm 1/5W 5% T
R223	RCFT-E332J-000	RESISTOR-CARBON FILM 3.3Kohm 1/5W 5% T
R224	RCFT-E332J-000	RESISTOR-CARBON FILM 3.3Kohm 1/5W 5% T
R227	RCFT-E392J-000	RESISTOR-CARBON FILM 3.9Kohm 1/5W 5% T
R248	RCFT-E4R7J-000	RESISTOR-CARBON FILM 4.7ohm 1/5W 5% T
R228	RCFT-E470J-000	RESISTOR-CARBON FILM 47ohm 1/5W 5% T
R103	RCFT-E471J-000	RESISTOR-CARBON FILM 470ohm 1/5W 5% T
R104	RCFT-E471J-000	RESISTOR-CARBON FILM 470ohm 1/5W 5% T
R105	RCFT-E471J-000	RESISTOR-CARBON FILM 470ohm 1/5W 5% T



Ref. No.	Part No.	Description
<b>BLOCK MAIN PCB</b>		
R106	RCFT-E471J-000	RESISTOR-CARBON FILM 470ohm 1/5W 5% T
R107	RCFT-E471J-000	RESISTOR-CARBON FILM 470ohm 1/5W 5% T
R108	RCFT-E471J-000	RESISTOR-CARBON FILM 470ohm 1/5W 5% T
R109	RCFT-E471J-000	RESISTOR-CARBON FILM 470ohm 1/5W 5% T
R110	RCFT-E471J-000	RESISTOR-CARBON FILM 470ohm 1/5W 5% T
R111	RCFT-E471J-000	RESISTOR-CARBON FILM 470ohm 1/5W 5% T
R112	RCFT-E471J-000	RESISTOR-CARBON FILM 470ohm 1/5W 5% T
R113	RCFT-E471J-000	RESISTOR-CARBON FILM 470ohm 1/5W 5% T
R114	RCFT-E471J-000	RESISTOR-CARBON FILM 470ohm 1/5W 5% T
R129	RCFT-E471J-000	RESISTOR-CARBON FILM 470ohm 1/5W 5% T
R130	RCFT-E471J-000	RESISTOR-CARBON FILM 470ohm 1/5W 5% T
R143	RCFT-E471J-000	RESISTOR-CARBON FILM 470ohm 1/5W 5% T
R144	RCFT-E471J-000	RESISTOR-CARBON FILM 470ohm 1/5W 5% T
R205	RCFT-E471J-000	RESISTOR-CARBON FILM 470ohm 1/5W 5% T
R206	RCFT-E471J-000	RESISTOR-CARBON FILM 470ohm 1/5W 5% T
R127	RCFT-E473J-000	RESISTOR-CARBON FILM 47Kohm 1/5W 5% T
R128	RCFT-E473J-000	RESISTOR-CARBON FILM 47Kohm 1/5W 5% T
R141	RCFT-E473J-000	RESISTOR-CARBON FILM 47Kohm 1/5W 5% T
R142	RCFT-E473J-000	RESISTOR-CARBON FILM 47Kohm 1/5W 5% T
R229	RCFT-E473J-000	RESISTOR-CARBON FILM 47Kohm 1/5W 5% T
R125	RCFT-E564J-000	RESISTOR-CARBON FILM 560Kohm 1/5W 5% T
R126	RCFT-E564J-000	RESISTOR-CARBON FILM 560Kohm 1/5W 5% T
R123	RCFT-E751J-000	RESISTOR-CARBON FILM 750ohm 1/5W 5% T
R124	RCFT-E751J-000	RESISTOR-CARBON FILM 750ohm 1/5W 5% T
R231	RCFT-E823J-000	RESISTOR-CARBON FILM 82Kohm 1/5W 5% T
R245	RCFT-E823J-000	RESISTOR-CARBON FILM 82Kohm 1/5W 5% T
R246	RCFT-E823J-000	RESISTOR-CARBON FILM 82Kohm 1/5W 5% T
R237	RCFT-F4R7J-010	RESISTOR-CARBON FILM 4.7ohm 1/4W 5% T
R238	RCFT-F4R7J-010	RESISTOR-CARBON FILM 4.7ohm 1/4W 5% T
R247	RCFT-F4R7J-010	RESISTOR-CARBON FILM 4.7ohm 1/4W 5% T
R234	RCFT-G335K-1D0	RESISTOR-CARBON FILM 3.3Mohm 1/2W ERC12UGK335
R253	RMOH-H100J-100	RESISTOR-METAL OXIDE PRO1 1W 10ohm 5% R-SHAP
R233	RMOH-H4R7J-100	RESISTOR-METAL OXIDE PRO1 1W 4.7ohm J R-SHAPE
R241	RMOH-H4R7J-100	RESISTOR-METAL OXIDE PRO1 1W 4.7ohm J R-SHAPE
R242	RMOH-H4R7J-100	RESISTOR-METAL OXIDE PRO1 1W 4.7ohm J R-SHAPE
R249	RMOH-J100J-040	RESISTOR-METAL OXIDE 10ohm 2W 5% H
R250	RMOH-J100J-040	RESISTOR-METAL OXIDE 10ohm 2W 5% H
R251	RMOH-J100J-040	RESISTOR-METAL OXIDE 10ohm 2W 5% H
R252	RMOH-J100J-040	RESISTOR-METAL OXIDE 10ohm 2W 5% H
A0101	SKAO-00190-C50	AC OUTLET S2-764T-214
JK105	SKPH-00520-360	MINIATURE JACK HSJ1002-01-1020
JK101	SKRC-00290-020	SOCKET-RCA JK0200440N 2P
JK102	SKRC-00420-061	SOCKET-RCA JK0600460N
JK103	SKRC-00420-061	SOCKET-RCA JK0600460N
JK104	SKRC-00760-060	SOCKET-RCA JK0600467N
TE101	TESP-00230-08S	TERMINAL SPEAKER SH0810360P
Q102	TRTA-0012Y-SD0	TRANSISTOR P-H FREQ KTA1273-Y TO92L
Q106	TRTA-00940-SD0	TRANSISTOR P-H FREQ KRA107M W/RESIST TO92M
Q109	TRTA-00940-SD0	TRANSISTOR P-H FREQ KRA107M W/RESIST TO92M
	TRTC-01700-SD0	TRANSISTOR N-H FREQ KRC107M W/RESIST TO92M
Q101	TRTD-00200-SD0	TRANSISTOR N-L FREQ KTD-1302 TO92

Ref. No.	Part No.	Description				
<b>BLOCK MAIN PCB</b>						
Q103	TRTD-00200-SD0	TRANSISTOR N-L FREQ	KTD-1302			TO92
Q104	TRTD-00200-SD0	TRANSISTOR N-L FREQ	KTD-1302			TO92
Q107	TRTD-00200-SD0	TRANSISTOR N-L FREQ	KTD-1302			TO92
Q108	TRTD-00200-SD0	TRANSISTOR N-L FREQ	KTD-1302			TO92
Q111	TRTD-00200-SD0	TRANSISTOR N-L FREQ	KTD-1302			TO92
<b>BLOCK FRONT PCB</b>						
C302	CCAT-J104Z-AAF	CAPACITOR CERAMIC	0.1uF	Z 50V	F T	
C305	CCAT-J104Z-AAF	CAPACITOR CERAMIC	0.1uF	Z 50V	F T	
C306	CCAT-J104Z-AAF	CAPACITOR CERAMIC	0.1uF	Z 50V	F T	
C308	CCAT-J104Z-AAF	CAPACITOR CERAMIC	0.1uF	Z 50V	F T	
C314	CCAT-J104Z-AAF	CAPACITOR CERAMIC	0.1uF	Z 50V	F T	
C315	CCAT-J104Z-AAF	CAPACITOR CERAMIC	0.1uF	Z 50V	F T	
C503	CCAT-J330J-AAZ	CAPACITOR CERAMIC	33PF	J 50V	SL T	
C504	CCAT-J330J-AAZ	CAPACITOR CERAMIC	33PF	J 50V	SL T	
C317	CCAT-J470J-AAZ	CAPACITOR CERAMIC	47PF	J 50V	SL T	
C501	CCAT-J470J-AAZ	CAPACITOR CERAMIC	47PF	J 50V	SL T	
C502	CCAT-J470J-AAZ	CAPACITOR CERAMIC	47PF	J 50V	SL T	
C311	CCAT-J473Z-AAF	CAPACITOR CERAMIC	0.047uF	Z 50V	F T	
C312	CCAT-J473Z-AAF	CAPACITOR CERAMIC	0.047uF	Z 50V	F T	
C307	CCCT-J103Z-ODF	CAPACITOR CERAMIC	0.01uF	Z 50V	F T	
C413	CCTT-J120J-0BC	CAPACITOR CERAMIC	12PF	J 50V	CH T	
C414	CCTT-J120J-0BC	CAPACITOR CERAMIC	12PF	J 50V	CH T	
C419	CCTT-J470J-0DC	CAPACITOR CERAMIC	47PF	J 50V	CH T	
C420	CCTT-J470J-0DC	CAPACITOR CERAMIC	47PF	J 50V	CH T	
C403	CCTT-J680J-0FC	CAPACITOR CERAMIC	68PF	J 50V	CH T	
C404	CCTT-J680J-0FC	CAPACITOR CERAMIC	68PF	J 50V	CH T	
C409	CCTT-J681J-0BZ	CAPACITOR CERAMIC	680PF	J 50V	SL T	
C410	CCTT-J681J-0BZ	CAPACITOR CERAMIC	680PF	J 50V	SL T	
C411	CEET-C471M-FI1	CAPACITOR E/ALUMINUM	470uF	M 6.3V 8x11.5	U T	
C412	CEET-C471M-FI1	CAPACITOR E/ALUMINUM	470uF	M 6.3V 8x11.5	U T	
C428	CEET-C471M-FI1	CAPACITOR E/ALUMINUM	470uF	M 6.3V 8x11.5	U T	
C401	CEET-F220M-C10	CAPACITOR E/ALUMINUM	22uF	M 25V 5x11	T	
C402	CEET-F220M-C10	CAPACITOR E/ALUMINUM	22uF	M 25V 5x11	T	
C407	CEET-F220M-C10	CAPACITOR E/ALUMINUM	22uF	M 25V 5x11	T	
C408	CEET-F220M-C10	CAPACITOR E/ALUMINUM	22uF	M 25V 5x11	T	
C405	CEET-F330M-C10	CAPACITOR E/ALUMINUM	33uF	M 25V 5x11	T	
C406	CEET-F330M-C10	CAPACITOR E/ALUMINUM	33uF	M 25V 5x11	T	
C304	CEET-F470M-C10	CAPACITOR E/ALUMINUM	47uF	M 25V 5x11	T	
C316	CEET-F470M-C10	CAPACITOR E/ALUMINUM	47uF	M 25V 5x11	T	
C509	CEET-F470M-C10	CAPACITOR E/ALUMINUM	47uF	M 25V 5x11	T	
C510	CEET-F470M-C10	CAPACITOR E/ALUMINUM	47uF	M 25V 5x11	T	
C303	CEET-JR10M-C10	CAPACITOR E/ALUMINUM	0.1uF	M 50V 5x11	T	
C310	CEET-J1R0M-C10	CAPACITOR E/ALUMINUM	1.0uF	M 50V 5x11	T	
C427	CEET-J1R0M-C10	CAPACITOR E/ALUMINUM	1.0uF	M 50V 5x11	T	
C309	CEET-J100M-C10	CAPACITOR E/ALUMINUM	10uF	M 50V 5x11	T	
C421	CEET-J100M-C10	CAPACITOR E/ALUMINUM	10uF	M 50V 5x11	T	
C422	CEET-J100M-C10	CAPACITOR E/ALUMINUM	10uF	M 50V 5x11	T	
C425	CEET-J100M-C10	CAPACITOR E/ALUMINUM	10uF	M 50V 5x11	T	
C426	CEET-J100M-C10	CAPACITOR E/ALUMINUM	10uF	M 50V 5x11	T	
C505	CEET-J100M-C10	CAPACITOR E/ALUMINUM	10uF	M 50V 5x11	T	

Ref. No.	Part No.	Description
<b>BLOCK FRONT PCB</b>		
C506	CEET-J100M-C10	CAPACITOR E/ALUMINUM 10uF M 50V 5x11 T
C507	CEET-J100M-C10	CAPACITOR E/ALUMINUM 10uF M 50V 5x11 T
C508	CEET-J100M-C10	CAPACITOR E/ALUMINUM 10uF M 50V 5x11 T
C423	CEET-J4R7M-C10	CAPACITOR E/ALUMINUM 4.7uF M 50V 5x11 T
C424	CEET-J4R7M-C10	CAPACITOR E/ALUMINUM 4.7uF M 50V 5x11 T
C313	CEET-J470M-D10	CAPACITOR E/ALUMINUM 47uF M 50V 6.3x11 T
C415	CEET-L331M-D11	CAPACITOR E/ALUMINUM 330uF M 63V 10x20 SHL T
C416	CEET-L331M-D11	CAPACITOR E/ALUMINUM 330uF M 63V 10x20 SHL T
C417	CEET-L331M-D11	CAPACITOR E/ALUMINUM 330uF M 63V 10x20 SHL T
C418	CEET-L331M-D11	CAPACITOR E/ALUMINUM 330uF M 63V 10x20 SHL T
C301	CEGT-B104J-0J0	CAPACITOR E/DO LAYER 0.1F J 5.5V SCDA5R5104A T
C511	CFMT-N183J-EK0	CAPACITOR F/POLYESTR 0.018uF J 100V 7.3x13 T
C512	CFMT-N183J-EK0	CAPACITOR F/POLYESTR 0.018uF J 100V 7.3x13 T
C517	CFMT-N183J-EK0	CAPACITOR F/POLYESTR 0.018uF J 100V 7.3x13 T
C518	CFMT-N183J-EK0	CAPACITOR F/POLYESTR 0.018uF J 100V 7.3x13 T
C515	CFMT-N392J-DJ0	CAPACITOR F/POLYESTR 0.0039uF J 100V 5.8x12 T
C516	CFMT-N392J-DJ0	CAPACITOR F/POLYESTR 0.0039uF J 100V 5.8x12 T
C513	CFMT-N823J-IK0	CAPACITOR F/POLYESTR 0.082uF J 100V 10.6x14 T
C514	CFMT-N823J-IK0	CAPACITOR F/POLYESTR 0.082uF J 100V 10.6x14 T
D301	DDTS-00070-SO0	DIODE-SI 1SS133 (40V 0.11A) DO-40 T
D302	DDTS-00070-SO0	DIODE-SI 1SS133 (40V 0.11A) DO-40 T
D303	DDTS-00070-SO0	DIODE-SI 1SS133 (40V 0.11A) DO-40 T
D304	DDTS-00070-SO0	DIODE-SI 1SS133 (40V 0.11A) DO-40 T
D306	DDTS-00070-SO0	DIODE-SI 1SS133 (40V 0.11A) DO-40 T
D307	DDTS-00070-SO0	DIODE-SI 1SS133 (40V 0.11A) DO-40 T
D308	DDTS-00070-SO0	DIODE-SI 1SS133 (40V 0.11A) DO-40 T
D309	DDTS-00070-SO0	DIODE-SI 1SS133 (40V 0.11A) DO-40 T
D310	DDTS-00070-SO0	DIODE-SI 1SS133 (40V 0.11A) DO-40 T
D311	DDTS-00070-SO0	DIODE-SI 1SS133 (40V 0.11A) DO-40 T
D312	DDTS-00070-SO0	DIODE-SI 1SS133 (40V 0.11A) DO-40 T
D401	DDTS-00070-SO0	DIODE-SI 1SS133 (40V 0.11A) DO-40 T
D402	DDTS-00070-SO0	DIODE-SI 1SS133 (40V 0.11A) DO-40 T
D403	DDTS-00070-SO0	DIODE-SI 1SS133 (40V 0.11A) DO-40 T
D404	DDTS-00070-SO0	DIODE-SI 1SS133 (40V 0.11A) DO-40 T
D405	DDTS-00070-SO0	DIODE-SI 1SS133 (40V 0.11A) DO-40 T
D305	DDTZ-G075B-SO0	DIODE ZENER MTZ7.5B 7.07-7.45 DO40 T
D406	DDTZ-G091B-SO0	DIODE ZENER MTZ9.1B 9.01 DO40 T
FL301	DPFL-00780-000	VFD HNA-16LL15
LD802	DPLE-00210-YG0	DISPLAY-LED SM3511
LD301	DPLE-00211-GG0	DISPLAY-LED SM3511(F2T)
LD302	DPLE-00211-GG0	DISPLAY-LED SM3511(F2T)
LD303	DPLE-00211-GG0	DISPLAY-LED SM3511(F2T)
LD304	DPLE-00211-GG0	DISPLAY-LED SM3511(F2T)
LD305	DPLE-00211-GG0	DISPLAY-LED SM3511(F2T)
LD306	DPLE-00211-GG0	DISPLAY-LED SM3511(F2T)
LD801	DPLE-00280-RG0	DISPLAY-LED SAM5270 RED/GRN
IC304	ICCM-01500-SB0	IC MEMORY LSI BR24C04-W DIP8
IC703	ICHY-00370-U80	IC REMOTE RECEIVER HI-M602H0
IC301	ICMP-04110-SE0	IC (U-COM) UPD780204GF-084-3BA
IC303	ICOP-00210-SD0	IC RESET KIA7042P/F 4.2V TO-92
IC501	ICOP-03150-SG0	IC OP AMP NJM2068M SOP8

Ref. No.	Part No.	Description	
<b>BLOCK FRONT PCB</b>			
L302	KIBK-00190-E40	COIL-AUDIO CHOCK	0.7uH COIL-CHOCK
L401	KIBK-00190-E40	COIL-AUDIO CHOCK	0.7uH COIL-CHOCK
CN402	KNCW-00140-2TM	CONNECTOR-WAFER	5267-02A 2.5mm MILK
CN401	KNCW-00140-3TM	CONNECTOR-WAFER	5267-03A 2.5mm MILK
CN302	KNCW-00160-5S9	CONNECTOR-WAFER	53015-0510 2mm-WHT
CN301	KNCW-00823-KS9	CONNECTOR WAFER	6216-20PRA
CN801	KNCW-00990-2T9	CONNECTOR-WAFER	JE202A-1T-02
Z301	KTRE-00171-042	RESONATOR	CST4.19MGW-TF01
	MEAC-08212-004	RADIATOR	
	MRAG-13830-004	CUSHION-FL	EVA T=5.0
	MRAG-13840-004	CUSHION-REMOTE	EVA T=11.0
	PCSR-05400-11B	PCB-SINGLE	A1R-540 330x247x1.6t
R319	RCFT-E100J-000	RESISTOR-CARBON FILM	10ohm 1/5W 5% T
R346	RCFT-E100J-000	RESISTOR-CARBON FILM	10ohm 1/5W 5% T
R317	RCFT-E101J-000	RESISTOR-CARBON FILM	100ohm 1/5W 5% T
R318	RCFT-E101J-000	RESISTOR-CARBON FILM	100ohm 1/5W 5% T
R495	RCFT-E102J-000	RESISTOR-CARBON FILM	1Kohm 1/5W 5% T
R304	RCFT-E103J-000	RESISTOR-CARBON FILM	10Kohm 1/5W 5% T
R345	RCFT-E103J-000	RESISTOR-CARBON FILM	10Kohm 1/5W 5% T
R405	RCFT-E103J-000	RESISTOR-CARBON FILM	10Kohm 1/5W 5% T
R406	RCFT-E103J-000	RESISTOR-CARBON FILM	10Kohm 1/5W 5% T
R491	RCFT-E103J-000	RESISTOR-CARBON FILM	10Kohm 1/5W 5% T
R302	RCFT-E104J-000	RESISTOR-CARBON FILM	100Kohm 1/5W 5% T
R305	RCFT-E104J-000	RESISTOR-CARBON FILM	100Kohm 1/5W 5% T
R337	RCFT-E104J-000	RESISTOR-CARBON FILM	100Kohm 1/5W 5% T
R338	RCFT-E104J-000	RESISTOR-CARBON FILM	100Kohm 1/5W 5% T
R339	RCFT-E104J-000	RESISTOR-CARBON FILM	100Kohm 1/5W 5% T
R340	RCFT-E104J-000	RESISTOR-CARBON FILM	100Kohm 1/5W 5% T
R341	RCFT-E104J-000	RESISTOR-CARBON FILM	100Kohm 1/5W 5% T
R342	RCFT-E104J-000	RESISTOR-CARBON FILM	100Kohm 1/5W 5% T
R343	RCFT-E104J-000	RESISTOR-CARBON FILM	100Kohm 1/5W 5% T
R344	RCFT-E104J-000	RESISTOR-CARBON FILM	100Kohm 1/5W 5% T
R488	RCFT-E104J-000	RESISTOR-CARBON FILM	100Kohm 1/5W 5% T
R501	RCFT-E104J-000	RESISTOR-CARBON FILM	100Kohm 1/5W 5% T
R502	RCFT-E104J-000	RESISTOR-CARBON FILM	100Kohm 1/5W 5% T
R511	RCFT-E104J-000	RESISTOR-CARBON FILM	100Kohm 1/5W 5% T
R512	RCFT-E104J-000	RESISTOR-CARBON FILM	100Kohm 1/5W 5% T
R306	RCFT-E105J-000	RESISTOR-CARBON FILM	1Mohm 1/5W 5% T
R503	RCFT-E105J-000	RESISTOR-CARBON FILM	1Mohm 1/5W 5% T
R504	RCFT-E105J-000	RESISTOR-CARBON FILM	1Mohm 1/5W 5% T
R455	RCFT-E122J-000	RESISTOR-CARBON FILM	1.2Kohm 1/5W 5% T
R456	RCFT-E122J-000	RESISTOR-CARBON FILM	1.2Kohm 1/5W 5% T
R415	RCFT-E150J-000	RESISTOR-CARBON FILM	15ohm 1/5W 5% T
R416	RCFT-E150J-000	RESISTOR-CARBON FILM	15ohm 1/5W 5% T
R417	RCFT-E150J-000	RESISTOR-CARBON FILM	15ohm 1/5W 5% T
R418	RCFT-E150J-000	RESISTOR-CARBON FILM	15ohm 1/5W 5% T
R407	RCFT-E151J-000	RESISTOR-CARBON FILM	150ohm 1/5W 5% T
R408	RCFT-E151J-000	RESISTOR-CARBON FILM	150ohm 1/5W 5% T
R425	RCFT-E152J-000	RESISTOR-CARBON FILM	1.5Kohm 1/5W 5% T
R426	RCFT-E152J-000	RESISTOR-CARBON FILM	1.5Kohm 1/5W 5% T
R471	RCFT-E152J-000	RESISTOR-CARBON FILM	1.5Kohm 1/5W 5% T

Ref. No.	Part No.	Description
<b>BLOCK FRONT PCB</b>		
R472	RCFT-E152J-000	RESISTOR-CARBON FILM 1.5Kohm 1/5W 5% T
R490	RCFT-E152J-000	RESISTOR-CARBON FILM 1.5Kohm 1/5W 5% T
R494	RCFT-E153J-000	RESISTOR-CARBON FILM 15Kohm 1/5W 5% T
R320	RCFT-E181J-000	RESISTOR-CARBON FILM 180ohm 1/5W 5% T
R321	RCFT-E181J-000	RESISTOR-CARBON FILM 180ohm 1/5W 5% T
R322	RCFT-E181J-000	RESISTOR-CARBON FILM 180ohm 1/5W 5% T
R323	RCFT-E181J-000	RESISTOR-CARBON FILM 180ohm 1/5W 5% T
R324	RCFT-E181J-000	RESISTOR-CARBON FILM 180ohm 1/5W 5% T
R325	RCFT-E181J-000	RESISTOR-CARBON FILM 180ohm 1/5W 5% T
R469	RCFT-E182J-000	RESISTOR-CARBON FILM 1.8Kohm 1/5W 5% T
R470	RCFT-E182J-000	RESISTOR-CARBON FILM 1.8Kohm 1/5W 5% T
R507	RCFT-E203J-000	RESISTOR-CARBON FILM 20Kohm 1/5W 5% T
R508	RCFT-E203J-000	RESISTOR-CARBON FILM 20Kohm 1/5W 5% T
R519	RCFT-E221J-000	RESISTOR-CARBON FILM 220ohm 1/5W 5% T
R520	RCFT-E221J-000	RESISTOR-CARBON FILM 220ohm 1/5W 5% T
R513	RCFT-E222J-000	RESISTOR-CARBON FILM 2.2Kohm 1/5W 5% T
R514	RCFT-E222J-000	RESISTOR-CARBON FILM 2.2Kohm 1/5W 5% T
R517	RCFT-E222J-000	RESISTOR-CARBON FILM 2.2Kohm 1/5W 5% T
R518	RCFT-E222J-000	RESISTOR-CARBON FILM 2.2Kohm 1/5W 5% T
R301	RCFT-E223J-000	RESISTOR-CARBON FILM 22Kohm 1/5W 5% T
R303	RCFT-E223J-000	RESISTOR-CARBON FILM 22Kohm 1/5W 5% T
R334	RCFT-E223J-000	RESISTOR-CARBON FILM 22Kohm 1/5W 5% T
R335	RCFT-E223J-000	RESISTOR-CARBON FILM 22Kohm 1/5W 5% T
R336	RCFT-E223J-000	RESISTOR-CARBON FILM 22Kohm 1/5W 5% T
R451	RCFT-E223J-000	RESISTOR-CARBON FILM 22Kohm 1/5W 5% T
R452	RCFT-E223J-000	RESISTOR-CARBON FILM 22Kohm 1/5W 5% T
R453	RCFT-E223J-000	RESISTOR-CARBON FILM 22Kohm 1/5W 5% T
R454	RCFT-E223J-000	RESISTOR-CARBON FILM 22Kohm 1/5W 5% T
R493	RCFT-E223J-000	RESISTOR-CARBON FILM 22Kohm 1/5W 5% T
R477	RCFT-E243J-000	RESISTOR-CARBON FILM 24Kohm 1/5W 5% T
R478	RCFT-E243J-000	RESISTOR-CARBON FILM 24Kohm 1/5W 5% T
R313	RCFT-E271J-000	RESISTOR-CARBON FILM 270ohm 1/5W 5% T
R315	RCFT-E271J-000	RESISTOR-CARBON FILM 270ohm 1/5W 5% T
R463	RCFT-E3R3J-000	RESISTOR-CARBON FILM 3.3ohm 1/5W 5% T
R464	RCFT-E3R3J-000	RESISTOR-CARBON FILM 3.3ohm 1/5W 5% T
R465	RCFT-E3R3J-000	RESISTOR-CARBON FILM 3.3ohm 1/5W 5% T
R466	RCFT-E3R3J-000	RESISTOR-CARBON FILM 3.3ohm 1/5W 5% T
R401	RCFT-E331J-000	RESISTOR-CARBON FILM 330ohm 1/5W 5% T
R402	RCFT-E331J-000	RESISTOR-CARBON FILM 330ohm 1/5W 5% T
R489	RCFT-E332J-000	RESISTOR-CARBON FILM 3.3Kohm 1/5W 5% T
R316	RCFT-E333J-000	RESISTOR-CARBON FILM 33Kohm 1/5W 5% T
R403	RCFT-E333J-000	RESISTOR-CARBON FILM 33Kohm 1/5W 5% T
R404	RCFT-E333J-000	RESISTOR-CARBON FILM 33Kohm 1/5W 5% T
R427	RCFT-E333J-000	RESISTOR-CARBON FILM 33Kohm 1/5W 5% T
R428	RCFT-E333J-000	RESISTOR-CARBON FILM 33Kohm 1/5W 5% T
R492	RCFT-E333J-000	RESISTOR-CARBON FILM 33Kohm 1/5W 5% T
R496	RCFT-E333J-000	RESISTOR-CARBON FILM 33Kohm 1/5W 5% T
R497	RCFT-E333J-000	RESISTOR-CARBON FILM 33Kohm 1/5W 5% T
R479	RCFT-E390J-000	RESISTOR-CARBON FILM 39ohm 1/5W 5% T
R480	RCFT-E390J-000	RESISTOR-CARBON FILM 39ohm 1/5W 5% T
R481	RCFT-E390J-000	RESISTOR-CARBON FILM 39ohm 1/5W 5% T

Ref. No.	Part No.	Description
<b>BLOCK FRONT PCB</b>		
R482	RCFT-E390J-000	RESISTOR-CARBON FILM 39ohm 1/5W 5% T
R483	RCFT-E390J-000	RESISTOR-CARBON FILM 39ohm 1/5W 5% T
R484	RCFT-E390J-000	RESISTOR-CARBON FILM 39ohm 1/5W 5% T
R485	RCFT-E390J-000	RESISTOR-CARBON FILM 39ohm 1/5W 5% T
R486	RCFT-E390J-000	RESISTOR-CARBON FILM 39ohm 1/5W 5% T
R509	RCFT-E432J-000	RESISTOR-CARBON FILM 4.3Kohm 1/5W 5% T
R510	RCFT-E432J-000	RESISTOR-CARBON FILM 4.3Kohm 1/5W 5% T
R505	RCFT-E471J-000	RESISTOR-CARBON FILM 470ohm 1/5W 5% T
R506	RCFT-E471J-000	RESISTOR-CARBON FILM 470ohm 1/5W 5% T
R309	RCFT-E472J-000	RESISTOR-CARBON FILM 4.7Kohm 1/5W 5% T
R310	RCFT-E472J-000	RESISTOR-CARBON FILM 4.7Kohm 1/5W 5% T
R311	RCFT-E472J-000	RESISTOR-CARBON FILM 4.7Kohm 1/5W 5% T
R312	RCFT-E472J-000	RESISTOR-CARBON FILM 4.7Kohm 1/5W 5% T
R441	RCFT-E472J-000	RESISTOR-CARBON FILM 4.7Kohm 1/5W 5% T
R442	RCFT-E472J-000	RESISTOR-CARBON FILM 4.7Kohm 1/5W 5% T
R307	RCFT-E473J-000	RESISTOR-CARBON FILM 47Kohm 1/5W 5% T
R326	RCFT-E473J-000	RESISTOR-CARBON FILM 47Kohm 1/5W 5% T
R327	RCFT-E473J-000	RESISTOR-CARBON FILM 47Kohm 1/5W 5% T
R328	RCFT-E473J-000	RESISTOR-CARBON FILM 47Kohm 1/5W 5% T
R329	RCFT-E473J-000	RESISTOR-CARBON FILM 47Kohm 1/5W 5% T
R331	RCFT-E473J-000	RESISTOR-CARBON FILM 47Kohm 1/5W 5% T
R333	RCFT-E473J-000	RESISTOR-CARBON FILM 47Kohm 1/5W 5% T
R314	RCFT-E561J-000	RESISTOR-CARBON FILM 560ohm 1/5W 5% T
R429	RCFT-E561J-000	RESISTOR-CARBON FILM 560ohm 1/5W 5% T
R430	RCFT-E561J-000	RESISTOR-CARBON FILM 560ohm 1/5W 5% T
R431	RCFT-E561J-000	RESISTOR-CARBON FILM 560ohm 1/5W 5% T
R432	RCFT-E561J-000	RESISTOR-CARBON FILM 560ohm 1/5W 5% T
R433	RCFT-E561J-000	RESISTOR-CARBON FILM 560ohm 1/5W 5% T
R434	RCFT-E561J-000	RESISTOR-CARBON FILM 560ohm 1/5W 5% T
R435	RCFT-E561J-000	RESISTOR-CARBON FILM 560ohm 1/5W 5% T
R436	RCFT-E561J-000	RESISTOR-CARBON FILM 560ohm 1/5W 5% T
R437	RCFT-E561J-000	RESISTOR-CARBON FILM 560ohm 1/5W 5% T
R438	RCFT-E561J-000	RESISTOR-CARBON FILM 560ohm 1/5W 5% T
R439	RCFT-E561J-000	RESISTOR-CARBON FILM 560ohm 1/5W 5% T
R440	RCFT-E561J-000	RESISTOR-CARBON FILM 560ohm 1/5W 5% T
R473	RCFT-E561J-000	RESISTOR-CARBON FILM 560ohm 1/5W 5% T
R474	RCFT-E561J-000	RESISTOR-CARBON FILM 560ohm 1/5W 5% T
R515	RCFT-E561J-000	RESISTOR-CARBON FILM 560ohm 1/5W 5% T
R516	RCFT-E561J-000	RESISTOR-CARBON FILM 560ohm 1/5W 5% T
R492	RCFT-E563J-000	RESISTOR-CARBON FILM 56Kohm 1/5W 5% T
R409	RCFT-E680J-000	RESISTOR-CARBON FILM 68ohm 1/5W 5% T
R410	RCFT-E680J-000	RESISTOR-CARBON FILM 68ohm 1/5W 5% T
R419	RCFT-E681J-000	RESISTOR-CARBON FILM 680ohm 1/5W 5% T
R420	RCFT-E681J-000	RESISTOR-CARBON FILM 680ohm 1/5W 5% T
R475	RCFT-E682J-000	RESISTOR-CARBON FILM 6.8Kohm 1/5W 5% T
R476	RCFT-E682J-000	RESISTOR-CARBON FILM 6.8Kohm 1/5W 5% T
R487	RCFT-E683J-000	RESISTOR-CARBON FILM 68Kohm 1/5W 5% T
R421	RCFT-E751J-000	RESISTOR-CARBON FILM 750ohm 1/5W 5% T
R422	RCFT-E751J-000	RESISTOR-CARBON FILM 750ohm 1/5W 5% T
R423	RCFT-E751J-000	RESISTOR-CARBON FILM 750ohm 1/5W 5% T
R424	RCFT-E751J-000	RESISTOR-CARBON FILM 750ohm 1/5W 5% T

Ref. No.	Part No.	Description
<b>BLOCK FRONT PCB</b>		
R443	RCFT-E820J-000	RESISTOR-CARBON FILM 82ohm 1/5W 5% T
R444	RCFT-E820J-000	RESISTOR-CARBON FILM 82ohm 1/5W 5% T
R445	RCFT-E820J-000	RESISTOR-CARBON FILM 82ohm 1/5W 5% T
R446	RCFT-E820J-000	RESISTOR-CARBON FILM 82ohm 1/5W 5% T
R461	RCFT-E820J-000	RESISTOR-CARBON FILM 82ohm 1/5W 5% T
R462	RCFT-E820J-000	RESISTOR-CARBON FILM 82ohm 1/5W 5% T
R457	RCFT-E821J-000	RESISTOR-CARBON FILM 820ohm 1/5W 5% T
R458	RCFT-E821J-000	RESISTOR-CARBON FILM 820ohm 1/5W 5% T
R459	RCFT-E821J-000	RESISTOR-CARBON FILM 820ohm 1/5W 5% T
R460	RCFT-E821J-000	RESISTOR-CARBON FILM 820ohm 1/5W 5% T
	RJWT-00000-AA0	RESISTOR-JUMPER WIRE 60mm-TX123 F 1
R467	RMFT-LR27J-0J0	RESISTOR-METAL PLATE 0.27ohm 5W 5% MPR
R468	RMFT-LR27J-0J0	RESISTOR-METAL PLATE 0.27ohm 5W 5% MPR
R447	RMOH-H470J-100	RESISTOR-METAL OXIDE PRO1 1W 470hm 5% R-SHAF
R448	RMOH-H470J-100	RESISTOR-METAL OXIDE PRO1 1W 470hm 5% R-SHAF
R449	RMOH-H470J-100	RESISTOR-METAL OXIDE PRO1 1W 470hm 5% R-SHAF
R450	RMOH-H470J-100	RESISTOR-METAL OXIDE PRO1 1W 470hm 5% R-SHAF
R801	RMOH-J221J-040	RESISTOR-METAL OXIDE 220ohm 2W 5% H
R802	RMOH-J221J-040	RESISTOR-METAL OXIDE 220ohm 2W 5% H
SW801	SWPU-00591-059	SWITCH-PUSH SDDL13300
SW301	SWTA-00220-060	SWITCH-TACT THVV 502G AA 12V 50mA
SW302	SWTA-00220-060	SWITCH-TACT THVV 502G AA 12V 50mA
SW303	SWTA-00220-060	SWITCH-TACT THVV 502G AA 12V 50mA
SW304	SWTA-00220-060	SWITCH-TACT THVV 502G AA 12V 50mA
SW305	SWTA-00220-060	SWITCH-TACT THVV 502G AA 12V 50mA
SW306	SWTA-00220-060	SWITCH-TACT THVV 502G AA 12V 50mA
SW307	SWTA-00220-060	SWITCH-TACT THVV 502G AA 12V 50mA
SW308	SWTA-00220-060	SWITCH-TACT THVV 502G AA 12V 50mA
SW309	SWTA-00220-060	SWITCH-TACT THVV 502G AA 12V 50mA
SW310	SWTA-00220-060	SWITCH-TACT THVV 502G AA 12V 50mA
SW311	SWTA-00220-060	SWITCH-TACT THVV 502G AA 12V 50mA
SW312	SWTA-00220-060	SWITCH-TACT THVV 502G AA 12V 50mA
SW313	SWTA-00220-060	SWITCH-TACT THVV 502G AA 12V 50mA
SW314	SWTA-00220-060	SWITCH-TACT THVV 502G AA 12V 50mA
SW315	SWTA-00220-060	SWITCH-TACT THVV 502G AA 12V 50mA
SW316	SWTA-00220-060	SWITCH-TACT THVV 502G AA 12V 50mA
SW317	SWTA-00220-060	SWITCH-TACT THVV 502G AA 12V 50mA
SW318	SWTA-00220-060	SWITCH-TACT THVV 502G AA 12V 50mA
SW802	SWTA-00220-060	SWITCH-TACT THVV 502G AA 12V 50mA
Q423	TRSA-01450-SJ0	TRANSISTOR N-H FREQ 2SA1859A
Q424	TRSA-01450-SJ0	TRANSISTOR N-H FREQ 2SA1859A
Q421	TRSC-01540-SJ0	TRANSISTOR N-H FREQ 2SC4883A
Q422	TRSC-01540-SJ0	TRANSISTOR N-H FREQ 2SC4883A
Q401	TRTA-0011G-SD0	TRANSISTOR P-H FREQ KTA1268-GR TO92
Q402	TRTA-0011G-SD0	TRANSISTOR P-H FREQ KTA1268-GR TO92
Q403	TRTA-0011G-SD0	TRANSISTOR P-H FREQ KTA1268-GR TO92
Q404	TRTA-0011G-SD0	TRANSISTOR P-H FREQ KTA1268-GR TO92
Q405	TRTA-0011G-SD0	TRANSISTOR P-H FREQ KTA1268-GR TO92
Q406	TRTA-0011G-SD0	TRANSISTOR P-H FREQ KTA1268-GR TO92
Q407	TRTA-0011G-SD0	TRANSISTOR P-H FREQ KTA1268-GR TO92
Q408	TRTA-0011G-SD0	TRANSISTOR P-H FREQ KTA1268-GR TO92

Q425	TRSC-01340-SJO	TRANSISTOR NPN	2SC3856
Q426	TRSC-01340-SJO	TRANSISTOR NPN	2SC3856
Q427	TRSA-00950-SJO	TRANSISTOR PNP	2SA1492
Q428	TRSA-00950-SJO	TRANSISTOR PNP	2SA1492

Ref. No.	Part No.	Description		
<b>BLOCK FRONT PCB</b>				
Q413	TRTA-0011G-SD0	TRANSISTOR P-H FREQ	KTA1268-GR	TO92
Q414	TRTA-0011G-SD0	TRANSISTOR P-H FREQ	KTA1268-GR	TO92
Q431	TRTA-0011G-SD0	TRANSISTOR P-H FREQ	KTA1268-GR	TO92
Q415	TRTA-0013Y-SD0	TRANSISTOR N-H FREQ	KTA1024-Y	
Q416	TRTA-0013Y-SD0	TRANSISTOR N-H FREQ	KTA1024-Y	
Q409	TRTC-0015G-SD0	TRANSISTOR N-H FREQ	KTC3200-GR	TO92
Q410	TRTC-0015G-SD0	TRANSISTOR N-H FREQ	KTC3200-GR	TO92
Q411	TRTC-0015G-SD0	TRANSISTOR N-H FREQ	KTC3200-GR	TO92
Q412	TRTC-0015G-SD0	TRANSISTOR N-H FREQ	KTC3200-GR	TO92
Q429	TRTC-0015G-SD0	TRANSISTOR N-H FREQ	KTC3200-GR	TO92
Q430	TRTC-0015G-SD0	TRANSISTOR N-H FREQ	KTC3200-GR	TO92
Q301	TRTC-0016G-SD0	TRANSISTOR N-H FREQ	KTC3198-GR	TO92
Q432	TRTC-0016G-SD0	TRANSISTOR N-H FREQ	KTC3198-GR	TO92
Q433	TRTC-0016G-SD0	TRANSISTOR N-H FREQ	KTC3198-GR	TO92
Q434	TRTC-0016G-SD0	TRANSISTOR N-H FREQ	KTC3198-GR	TO92
Q417	TRTC-0087Y-SD0	TRANSISTOR N-H FREQ	KTC3206-Y	TO92L
Q418	TRTC-0087Y-SD0	TRANSISTOR N-H FREQ	KTC3206-Y	TO92L
Q302	TRTC-01700-SD0	TRANSISTOR N-H FREQ	KRC107M	W/RESIST TO92M
Q303	TRTC-01700-SD0	TRANSISTOR N-H FREQ	KRC107M	W/RESIST TO92M
Q304	TRTC-01700-SD0	TRANSISTOR N-H FREQ	KRC107M	W/RESIST TO92M
Q305	TRTC-01700-SD0	TRANSISTOR N-H FREQ	KRC107M	W/RESIST TO92M
Q306	TRTC-01700-SD0	TRANSISTOR N-H FREQ	KRC107M	W/RESIST TO92M
Q435	TRTC-01700-SD0	TRANSISTOR N-H FREQ	KRC107M	W/RESIST TO92M
	UA10-9M412-200	WIRE-ASS'Y	1007#20	WHT-120 10P
	UM08-A1033-000	WIRE-ASS'Y	1533#28/1007#26-150	10P
	UM08-41035-000	WIRE-ASS'Y	1533#28-180	4P
	U1T1-0GN20-T10	WIRE-ASS'Y	HIGH WRAP#22	BLK 200
	U208-2K815-000	WIRE-ASS'Y	20080#28	RED-150 2P
	U245-91327-450	WIRE-ASS'Y	1007#18-270	2P
	U508-4M716-200	WIRE-ASS'Y	1007#26	YEL-160 5P
	U710-6M742-200	WIRE-ASS'Y	1007#26	BLU-420
VR503	VRAE-P049W-104	VR-ROTARY	RK11K1160106-100KW	
VR501	VRAE-P050C-104	VR-ROTARY	RK14K1260106-100KCx2	
VR502	VRAE-P050C-104	VR-ROTARY	RK14K1260106-100KCx2	
<b>BLOCK TUNER PCB</b>				
CF602	BTCE-00040-107	FILTER-CERAMIC	SFE10.7MS2-A-TF21	
CF603	BTCE-00040-107	FILTER-CERAMIC	SFE10.7MS2-A-TF21	
CF604	BTCE-00450-045	FILTER-CERAMIC	AHCFM2-450AL	
C707	CCAT-F103Z-AAF	CAPACITOR CERAMIC	0.01uF	Z 25V F T
C708	CCAT-F103Z-AAF	CAPACITOR CERAMIC	0.01uF	Z 25V F T
C709	CCAT-F103Z-AAF	CAPACITOR CERAMIC	0.01uF	Z 25V F T
C710	CCAT-F103Z-AAF	CAPACITOR CERAMIC	0.01uF	Z 25V F T
C706	CCAT-F223Z-AAF	CAPACITOR CERAMIC	0.022uF	Z 25V F T
C620	CCAT-J101K-AAB	CAPACITOR CERAMIC	100PF	K 50V B T
C621	CCAT-J101K-AAB	CAPACITOR CERAMIC	100PF	K 50V B T
C626	CCAT-J101K-AAB	CAPACITOR CERAMIC	100PF	K 50V B T
C627	CCAT-J101K-AAB	CAPACITOR CERAMIC	100PF	K 50V B T
C628	CCAT-J101K-AAB	CAPACITOR CERAMIC	100PF	K 50V B T
C629	CCAT-J101K-AAB	CAPACITOR CERAMIC	100PF	K 50V B T
C640	CCAT-J104Z-AAF	CAPACITOR CERAMIC	0.1uF	Z 50V F T



Ref. No.	Part No.	Description						
<b>BLOCK TUNER PCB</b>								
C641	CCAT-J104Z-AAF	CAPACITOR CERAMIC	0.1uF	Z 50V	F	T		
C642	CCAT-J104Z-AAF	CAPACITOR CERAMIC	0.1uF	Z 50V	F	T		
C803	CCAT-J104Z-AAF	CAPACITOR CERAMIC	0.1uF	Z 50V	F	T		
C669	CCAT-J473Z-AAF	CAPACITOR CERAMIC	0.047uF	Z 50V	F	T		
C711	CCAT-J473Z-AAF	CAPACITOR CERAMIC	0.047uF	Z 50V	F	T		
C703	CCAT-J560J-AAZ	CAPACITOR CERAMIC	56PF	J 50V	SL	T		
C704	CCAT-J560J-AAZ	CAPACITOR CERAMIC	56PF	J 50V	SL	T		
C652	CCAT-J561K-AAB	CAPACITOR CERAMIC	560PF	K 50V	B	T		
C665	CCAT-J561K-AAB	CAPACITOR CERAMIC	560PF	K 50V	B	T		
C666	CCAT-J680J-AAZ	CAPACITOR CERAMIC	68PF	J 50V	SL	T		
C667	CCAT-J680J-AAZ	CAPACITOR CERAMIC	68PF	J 50V	SL	T		
C613	CCCT-J103Z-0DF	CAPACITOR CERAMIC	0.01uF	Z 50V	F	T		
C623	CCCT-J103Z-0DF	CAPACITOR CERAMIC	0.01uF	Z 50V	F	T		
C801	CCCT-J222K-0DB	CAPACITOR CERAMIC	2200PF	K 50V	B	T		
C802	CCCT-J222K-0DB	CAPACITOR CERAMIC	2200PF	K 50V	B	T		
C602	CCCT-J223Z-OFF	CAPACITOR CERAMIC	0.022uF	Z 50V	F	T		
C605	CCCT-J223Z-OFF	CAPACITOR CERAMIC	0.022uF	Z 50V	F	T		
C606	CCCT-J223Z-OFF	CAPACITOR CERAMIC	0.022uF	Z 50V	F	T		
C608	CCCT-J223Z-OFF	CAPACITOR CERAMIC	0.022uF	Z 50V	F	T		
C609	CCCT-J223Z-OFF	CAPACITOR CERAMIC	0.022uF	Z 50V	F	T		
C610	CCCT-J223Z-OFF	CAPACITOR CERAMIC	0.022uF	Z 50V	F	T		
C611	CCCT-J223Z-OFF	CAPACITOR CERAMIC	0.022uF	Z 50V	F	T		
C614	CCCT-J223Z-OFF	CAPACITOR CERAMIC	0.022uF	Z 50V	F	T		
C615	CCCT-J223Z-OFF	CAPACITOR CERAMIC	0.022uF	Z 50V	F	T		
C616	CCCT-J223Z-OFF	CAPACITOR CERAMIC	0.022uF	Z 50V	F	T		
C636	CCCT-J223Z-OFF	CAPACITOR CERAMIC	0.022uF	Z 50V	F	T		
C639	CCCT-J223Z-OFF	CAPACITOR CERAMIC	0.022uF	Z 50V	F	T		
C661	CCCT-J223Z-OFF	CAPACITOR CERAMIC	0.022uF	Z 50V	F	T		
C603	CCCT-J473Z-0JF	CAPACITOR CERAMIC	0.047uF	Z 50V	F	T		
C619	CCCT-J473Z-0JF	CAPACITOR CERAMIC	0.047uF	Z 50V	F	T		
C604	CCTT-J150J-0BC	CAPACITOR CERAMIC	15PF	J 50V	CH	T		
C625	CCTT-J300J-0CC	CAPACITOR CERAMIC	30PF	J 50V	CH	T		
C634	CCTT-J331J-0FZ	CAPACITOR CERAMIC	330PF	J 50V	SL	T		
C624	CCTT-J390J-0DC	CAPACITOR CERAMIC	39PF	J 50V	CH	T		
C651	CCTT-J681J-0BZ	CAPACITOR CERAMIC	680PF	J 50V	SL	T		
C645	CEET-E101M-DIO	CAPACITOR E/ALUMINUM	100uF	M 16V 6.3x11		T		
C705	CEET-E101M-DIO	CAPACITOR E/ALUMINUM	100uF	M 16V 6.3x11		T		
C601	CEET-F470M-CIO	CAPACITOR E/ALUMINUM	47uF	M 25V 5x11		T		
C612	CEET-F470M-CIO	CAPACITOR E/ALUMINUM	47uF	M 25V 5x11		T		
C618	CEET-F470M-CIO	CAPACITOR E/ALUMINUM	47uF	M 25V 5x11		T		
C622	CEET-F470M-CIO	CAPACITOR E/ALUMINUM	47uF	M 25V 5x11		T		
C638	CEET-F470M-CIO	CAPACITOR E/ALUMINUM	47uF	M 25V 5x11		T		
C701	CEET-F470M-CIO	CAPACITOR E/ALUMINUM	47uF	M 25V 5x11		T		
C702	CEET-F470M-CIO	CAPACITOR E/ALUMINUM	47uF	M 25V 5x11		T		
C607	CEET-G100M-CIO	CAPACITOR E/ALUMINUM	10uF	M 35V 5x11		T		
C647	CEET-G100M-CIO	CAPACITOR E/ALUMINUM	10uF	M 35V 5x11		T		
C648	CEET-G100M-CIO	CAPACITOR E/ALUMINUM	10uF	M 35V 5x11		T		
C664	CEET-G100M-CIO	CAPACITOR E/ALUMINUM	10uF	M 35V 5x11		T		
C663	CEET-JR22M-CIO	CAPACITOR E/ALUMINUM	0.22uF	M 50V 5x11		T		
C630	CEET-JR47M-CIO	CAPACITOR E/ALUMINUM	0.47uF	M 50V 5x11		T		
C632	CEET-J1R0M-CIO	CAPACITOR E/ALUMINUM	1.0uF	M 50V 5x11		T		

Ref. No.	Part No.	Description
<b>BLOCK TUNER PCB</b>		
C644	CEET-J1R0M-C10	CAPACITOR E/ALUMINUM 1.0uF M 50V 5x11 T
C662	CEET-J1R0M-C10	CAPACITOR E/ALUMINUM 1.0uF M 50V 5x11 T
C633	CEET-J3R3M-C10	CAPACITOR E/ALUMINUM 3.3uF M 50V 5x11 T
C617	CEET-J4R7M-C10	CAPACITOR E/ALUMINUM 4.7uF M 50V 5x11 T
C631	CEET-J4R7M-C10	CAPACITOR E/ALUMINUM 4.7uF M 50V 5x11 T
C643	CEET-J4R7M-C10	CAPACITOR E/ALUMINUM 4.7uF M 50V 5x11 T
C650	CEET-J4R7M-C10	CAPACITOR E/ALUMINUM 4.7uF M 50V 5x11 T
C668	CEET-J4R7M-C10	CAPACITOR E/ALUMINUM 4.7uF M 50V 5x11 T
C670	CFMT-N223J-EK0	CAPACITOR F/POLYESTR 0.022uF J 100V 7.4x13 T
C637	CFMT-N332J-DJ0	CAPACITOR F/POLYESTR 0.0033uF J 100V 5.8x12 T
C646	CFMT-N393J-FK0	CAPACITOR F/POLYESTR 0.039uF J 100V 8.5x13. T
C671	CFST-O471J-CJ0	CAPACITOR F/STYROL 470PF J 125V 5.5x12 T
VD601	DDSV-00120-S10	DIODE-VVC SVC321SPA-C2 AM8V DO40S
VD602	DDSV-00120-S10	DIODE-VVC SVC321SPA-C2 AM8V DO40S
D601	DDTS-00070-SO0	DIODE-SI 1SS133 (40V 0.11A) DO-40 T
D801	DDTS-00070-SO0	DIODE-SI 1SS133 (40V 0.11A) DO-40 T
D802	DDTS-00070-SO0	DIODE-SI 1SS133 (40V 0.11A) DO-40 T
ZD601	DDTZ-G051B-SOS	DIODE ZENER MTZJ5.1B 4.94-5.20 DO34 T
D701	DDTZ-G062B-SOS	DIODE ZENER MTZJ6.2B 5.96-6.27 DO34 T
IC701	ICDG-00560-SO0	IC MOTOR DRIVER BA6208 SIP9
IC603	ICLN-03610-S10	IC PLL FM MPX LA3401 DIP22
IC604	ICLN-03620-S10	IC AM/FM IF LA1266 DIP24
IC602	ICLN-03680-S10	IC PLL LC7218JM SOP-24
T606	IFFA-00110-E20	IFT-FM AFA011 7mm-CAN
T604	IFFD-00100-E20	IFT-FM DET AFD010 7mm-CAN
T605	KIAA-00260-E20	COIL-AM IFT AAA-026 7MC-K502713N4-KR
T603	KIAO-00460-E20	COIL-AM OSC AAO046 MW 7mm - CAN
T607	KIAT-00530-E20	COIL-AM ANT AAT053 MW 7mm - CAN
T601	KIML-A0010-E20	COIL-FM MPX FILTER AMA001 19KHz 10mm-CAN
T602	KIML-A0010-E20	COIL-FM MPX FILTER AMA001 19KHz 10mm-CAN
CN702	KNCW-00160-5S9	CONNECTOR-WAFER 53015-0510 2mm-WHT
CN701	KNCW-00240-AT9	CONNECTOR-WAFER 53014-10 2.0mm WHT
CW701	KNCW-00240-AT9	CONNECTOR-WAFER 53014-10 2.0mm WHT
CN703	KNCW-00240-2T9	CONNECTOR-WAFER 53014-02 2.0mm WHT
CW802	KNCW-00240-2T9	CONNECTOR-WAFER 53014-02 2.0mm WHT
TP601	KNCW-01490-2T9	CONNECTOR-WAFER JE115-AT-02P
TP602	KNCW-01490-2T9	CONNECTOR-WAFER JE115-AT-02P
TP603	KNCW-01490-2T9	CONNECTOR-WAFER JE115-AT-02P
CH602	KNCW-01510-ES9	CONNECTOR-WAFER 35237-1410 2M/M 14P
X601	KTAL-00041-072	CRYSTAL HC-49/U 7.200000MHz
CF605	KTRE-00300-288	RESONATOR ZTB456F11
R655	PCSR-01440-31B	PCB-SINGLE A3R-144 247x197x1.6t
R613	RCFT-E101J-000	RESISTOR-CARBON FILM 100ohm 1/5W 5% T
R629	RCFT-E101J-000	RESISTOR-CARBON FILM 100ohm 1/5W 5% T
R634	RCFT-E101J-000	RESISTOR-CARBON FILM 100ohm 1/5W 5% T
R639	RCFT-E101J-000	RESISTOR-CARBON FILM 100ohm 1/5W 5% T
R648	RCFT-E101J-000	RESISTOR-CARBON FILM 100ohm 1/5W 5% T
R651	RCFT-E101J-000	RESISTOR-CARBON FILM 100ohm 1/5W 5% T
R673	RCFT-E101J-000	RESISTOR-CARBON FILM 100ohm 1/5W 5% T
R603	RCFT-E102J-000	RESISTOR-CARBON FILM 1Kohm 1/5W 5% T
R611	RCFT-E102J-000	RESISTOR-CARBON FILM 1Kohm 1/5W 5% T

Ref. No.	Part No.	Description
<b>BLOCK TUNER PCB</b>		
R618	RCFT-E102J-000	RESISTOR-CARBON FILM 1Kohm 1/5W 5% T
R636	RCFT-E102J-000	RESISTOR-CARBON FILM 1Kohm 1/5W 5% T
R637	RCFT-E102J-000	RESISTOR-CARBON FILM 1Kohm 1/5W 5% T
R638	RCFT-E102J-000	RESISTOR-CARBON FILM 1Kohm 1/5W 5% T
R654	RCFT-E102J-000	RESISTOR-CARBON FILM 1Kohm 1/5W 5% T
R658	RCFT-E102J-000	RESISTOR-CARBON FILM 1Kohm 1/5W 5% T
R703	RCFT-E102J-000	RESISTOR-CARBON FILM 1Kohm 1/5W 5% T
R704	RCFT-E102J-000	RESISTOR-CARBON FILM 1Kohm 1/5W 5% T
R620	RCFT-E103J-000	RESISTOR-CARBON FILM 10Kohm 1/5W 5% T
R622	RCFT-E103J-000	RESISTOR-CARBON FILM 10Kohm 1/5W 5% T
R625	RCFT-E103J-000	RESISTOR-CARBON FILM 10Kohm 1/5W 5% T
R640	RCFT-E103J-000	RESISTOR-CARBON FILM 10Kohm 1/5W 5% T
R643	RCFT-E103J-000	RESISTOR-CARBON FILM 10Kohm 1/5W 5% T
R604	RCFT-E104J-000	RESISTOR-CARBON FILM 100Kohm 1/5W 5% T
R605	RCFT-E104J-000	RESISTOR-CARBON FILM 100Kohm 1/5W 5% T
R612	RCFT-E122J-000	RESISTOR-CARBON FILM 1.2Kohm 1/5W 5% T
R675	RCFT-E124J-000	RESISTOR-CARBON FILM 120Kohm 1/5W 5% T
R677	RCFT-E124J-000	RESISTOR-CARBON FILM 120Kohm 1/5W 5% T
R653	RCFT-E152J-000	RESISTOR-CARBON FILM 1.5Kohm 1/5W 5% T
R671	RCFT-E152J-000	RESISTOR-CARBON FILM 1.5Kohm 1/5W 5% T
R803	RCFT-E152J-000	RESISTOR-CARBON FILM 1.5Kohm 1/5W 5% T
R804	RCFT-E152J-000	RESISTOR-CARBON FILM 1.5Kohm 1/5W 5% T
R628	RCFT-E182J-000	RESISTOR-CARBON FILM 1.8Kohm 1/5W 5% T
R676	RCFT-E184J-000	RESISTOR-CARBON FILM 180Kohm 1/5W 5% T
R678	RCFT-E184J-000	RESISTOR-CARBON FILM 180Kohm 1/5W 5% T
R626	RCFT-E220J-000	RESISTOR-CARBON FILM 22ohm 1/5W 5% T
R630	RCFT-E220J-000	RESISTOR-CARBON FILM 22ohm 1/5W 5% T
R615	RCFT-E221J-000	RESISTOR-CARBON FILM 220ohm 1/5W 5% T
R616	RCFT-E221J-000	RESISTOR-CARBON FILM 220ohm 1/5W 5% T
R679	RCFT-E221J-000	RESISTOR-CARBON FILM 220ohm 1/5W 5% T
R614	RCFT-E222J-000	RESISTOR-CARBON FILM 2.2Kohm 1/5W 5% T
R642	RCFT-E223J-000	RESISTOR-CARBON FILM 22Kohm 1/5W 5% T
R650	RCFT-E223J-000	RESISTOR-CARBON FILM 22Kohm 1/5W 5% T
R619	RCFT-E271J-000	RESISTOR-CARBON FILM 270ohm 1/5W 5% T
R705	RCFT-E271J-000	RESISTOR-CARBON FILM 270ohm 1/5W 5% T
R627	RCFT-E273J-000	RESISTOR-CARBON FILM 27Kohm 1/5W 5% T
R607	RCFT-E331J-000	RESISTOR-CARBON FILM 330ohm 1/5W 5% T
R608	RCFT-E331J-000	RESISTOR-CARBON FILM 330ohm 1/5W 5% T
R609	RCFT-E332J-000	RESISTOR-CARBON FILM 3.3Kohm 1/5W 5% T
R635	RCFT-E332J-000	RESISTOR-CARBON FILM 3.3Kohm 1/5W 5% T
R652	RCFT-E332J-000	RESISTOR-CARBON FILM 3.3Kohm 1/5W 5% T
R672	RCFT-E332J-000	RESISTOR-CARBON FILM 3.3Kohm 1/5W 5% T
R674	RCFT-E332J-000	RESISTOR-CARBON FILM 3.3Kohm 1/5W 5% T
R606	RCFT-E4R7J-000	RESISTOR-CARBON FILM 4.7ohm 1/5W 5% T
R621	RCFT-E471J-000	RESISTOR-CARBON FILM 470ohm 1/5W 5% T
R623	RCFT-E472J-000	RESISTOR-CARBON FILM 4.7Kohm 1/5W 5% T
R631	RCFT-E472J-000	RESISTOR-CARBON FILM 4.7Kohm 1/5W 5% T
R632	RCFT-E472J-000	RESISTOR-CARBON FILM 4.7Kohm 1/5W 5% T
R633	RCFT-E472J-000	RESISTOR-CARBON FILM 4.7Kohm 1/5W 5% T
R646	RCFT-E472J-000	RESISTOR-CARBON FILM 4.7Kohm 1/5W 5% T
R624	RCFT-E473J-000	RESISTOR-CARBON FILM 47Kohm 1/5W 5% T

Ref. No.	Part No.	Description
<b>BLOCK TUNER PCB</b>		
R647	RCFT-E473J-000	RESISTOR-CARBON FILM 47Kohm 1/5W 5% T
R649	RCFT-E473J-000	RESISTOR-CARBON FILM 47Kohm 1/5W 5% T
R610	RCFT-E561J-000	RESISTOR-CARBON FILM 560ohm 1/5W 5% T
R644	RCFT-E622J-000	RESISTOR-CARBON FILM 6.2Kohm 1/5W 5% T
R617	RCFT-E683J-000	RESISTOR-CARBON FILM 68Kohm 1/5W 5% T
R702	RCFT-E821J-000	RESISTOR-CARBON FILM 820ohm 1/5W 5% T
R645	RCFT-E823J-000	RESISTOR-CARBON FILM 82Kohm 1/5W 5% T
R655	RCFT-G471J-190	RESISTOR-CARBON FILM 470ohm 1/2W 5% 2.3x6.5 T
	RJWT-00000-AA0	RESISTOR-JUMPER WIRE 60mm-TX123 F
R701	RMOH-H820J-100	MOR PRO1 1W 82ohm 5% R-SHAP
JK801	SKPH-00293-66W	SOCKET-PHONE HTJ064-05BG GOLD
ANT601	TEAT-00143-02S	TERMINAL ANTENNA SC021039FN
Q602	TRTA-00940-SD0	TRANSISTOR P-H FREQ KRA107M W/RESIST TO92M
Q604	TRTA-00940-SD0	TRANSISTOR P-H FREQ KRA107M W/RESIST TO92M
Q606	TRTA-00940-SD0	TRANSISTOR P-H FREQ KRA107M W/RESIST TO92M
Q609	TRTA-00940-SD0	TRANSISTOR P-H FREQ KRA107M W/RESIST TO92M
Q601	TRTC-0010Y-SD0	TRANSISTOR N-H FREQ KTC3194-Y TO92
Q607	TRTC-0016G-SD0	TRANSISTOR N-H FREQ KTC3198-GR TO92
Q608	TRTC-0016G-SD0	TRANSISTOR N-H FREQ KTC3198-GR TO92
Q610	TRTC-0016G-SD0	TRANSISTOR N-H FREQ KTC3198-GR TO92
Q701	TRTC-01060-SD0	TRANSISTOR N-H FREQ KTC3203 TO92
Q702	TRTC-01700-SD0	TRANSISTOR N-H FREQ KRC107M W/RESIST TO92M
Q603	TRTD-00200-SD0	TRANSISTOR N-L FREQ KTD-1302 TO92
Q605	TRTD-00200-SD0	TRANSISTOR N-L FREQ KTD-1302 TO92
FE601	TUFF-00232-00K	FM F/E TUNER FTA3-509HA
	UM08-A1034-000	WIRE-ASS'Y 1533#28/1007#26-200 10P
	U310-2M530-200	WIRE-ASS'Y 1007#22 RED-300 3P
CT601	VCTC-00022-200	TRIMMER CVCN06C200
VR602	VFEB-A021B-224	RESISTOR-SEMI FIXED RH0638C-220KB 220Kohm
VR603	VFEB-A021B-472	RESISTOR-SEMI FIXED RH0638C-4.7KB 4.7Kohm
VR601	VFEB-A021B-473	RESISTOR-SEMI FIXED RH0638C-47KB 47Kohm
MV701	VWBD-E017A-503	VR-W/MOTOR RK16812MG-50KAx2

Ref. No.	Part No.	Description	
	<b>BLOCK SUB</b>		
	ZBNG-00700-4ZL	BOND-ADHESIVE	#575
	ZBNG-01300-5ZL	LOCKER-SCREW	#1401B
#	ZGSI-01000-9PN	GREASE-SILICON	G-746
	ZSBR-00010-060	SOLDER-BAR	SN60
#	ZSWR-00010-F60	SOLDER-WIRE	D1.0 SN60
	<b>BLOCK MECHA</b>		
	ACRC-00680-000	ASS'Y-REMOCON	HK3470RC ( U. S. A □
	ANTL-00060-E50	ANTENNA-LOOP	AAN-007 19.5uH 7T 125x93
	ANNT-00054-075	ANTENNA-T TYPE	75ohm W/TER(Y)-1200m/m
	BAMN-00010-150	BATTERY MANGANESE	R03(AAAM) 1.5V 10.5x44.5
	FGFB-O2002-831	FUSE GLASS	2A 125V 51S
	FGFB-O3151-831	FUSE GLASS	315mA 125V 5x20 U/C SB
	FGFB-O8002-331	FUSE GLASS	8A 125V 5x20 U/C SB
	KDAC-0575D-H00	CORD-AC	KKP-10W WITH CORE
	LLA3-20401-E10	CARD CABLE	1.25x20Px360xCx(0.1x0.8)
	MAAF-03600-022	WINDOW-FL	HK3470RDS ACRYL T=3.0 (L
	MAAF-16130-014	LENS-VOLUME	HK3370 PMMA(IF-850)
	MAAF-16990-014	LENS-POWER	HK3370 ACRYL
	MAAF-17040-014	FILTER-FL	HK3370 PVC T0.5
	MAAF-17070-004	SHEET-WINDOW	PE(DRAFTING FILM)
	MEAC-05060-002	RADIATOR-MAIN	A6063 T-5+AL
	MJAF-03580-012	KNOB-FUNCTION	HK3370 ABS
	MJAF-06570-011	PANEL-FRONT	HK3370 ABS
	MJAF-08870-013	KNOB-CHOICE	HK3370 ABS
	MJAF-08880-013	DECO-CHOICE	HK3370 ABS
	MJAF-15640-014	FOOT(A)	AVR200
	MJAF-16050-024	KNOB-STANDBY	HK3470RDS ABS-720
	MJAF-16070-024	KNOB-BALANCE	HK3470RDS ABS-720
	MJAF-16100-024	KNOB-VOLUME	HK3470RDS ABS-720
	MJAF-16140-004	SUPPORT-PCB	ABS-720
	MJAF-16980-014	KNOB-POWER	HK3370 ABS
	MJAF-17030-004	GUIDE-LED	ABS
	MJAG-00280-003	CORD-BUSH	NIFCO
	MJAG-04540-004	CABLE-TIE-L80	*
	MLAG-13850-014	BADGE-H/K	HK3370 AL
	MMAC-12060-004	TERMINAL-GND	
	MMAC-15650-004	SCREW-RADIATOR	
	MMAC-16400-004	SCREW-T/P-TOOTH	3X10 BLACK
	MMAC-17070-004	JACK-CONNECT	
	MMSC-00900-004	AIR-STAPLER	
	MMTC-00751-003	SCREW-TAPPING	BHW T2T 3x8 FE-ZY
	MPAC-04812-002	CHASSIS-BOTTOM	US COATING T1.2
	MPAC-04950-012	CHASSIS-TOP	AVR200 SECC(T0.6) + P
	MPAC-05040-022	CHASSIS-BACK	HK3470 SECC T0.8
	MPAC-16220-004	BRACKET-RADIATOR(S)	US COATING T1.0
	MPAC-16880-004	SHIELD-BALANCE	ET-HD T0.5
	MRAG-13040-004	CUSHION-A	FELT 437x10x0.5 S
	MRAG-13050-004	CUSHION-A	FELT 250x10x0.5 S
	MRAG-13250-004	CUSHION-A	EVA T=5.0
	MRAG-13930-004	TRANSISTOR-MICA	MICA

Ref. No.	Part No.	Description	
<b>BLOCK MECHA</b>			
	MVAW-00910-003	PALLETS	1040X1126X141
	PLRC-00020-S30	PLUG RCA	SHORT JACK
	PTAP-03770-CJU	TRANSFORMER-POWER	A96-377C-U,AC120V 60Hz
	TFMA-00100-D00	TRANSFORMER-MATCHING	MT115050 300ohm & 75ohm
	TRSA-01770-SD0	TRANSISTOR P-H FREQ	2SA1943
	TRSA-01780-SD0	TRANSISTOR N-H FREQ	2SC5200
Q209	TRSC-01680-SB0	TRANSISTOR N-H FREQ	2SC4137 TO-126FP
Q224	TRSC-01680-SB0	TRANSISTOR N-H FREQ	2SC4137 TO-126FP
Q239	TRSC-01680-SB0	TRANSISTOR N-H FREQ	2SC4137 TO-126FP
Q254	TRSC-01680-SB0	TRANSISTOR N-H FREQ	2SC4137 TO-126FP
Q269	TRSC-01680-SB0	TRANSISTOR N-H FREQ	2SC4137 TO-126FP
	U348-9B350-480	WIRE-ASS'Y	1618#18-500 WHT 3P
	VSPO-00010-100	POSISTOR	P42T8D100BW23
	XSTB-30080-ZB4	SCREW-TAPPING	BHT2T 3x8 FE-ZB
	XSTB-30080-ZY4	SCREW-TAPPING	BHT2T 3x8 FE-ZY
	XSTB-30100-ZB4	SCREW-TAPPING	BHT2T 3x10 FE-ZB
	XSTB-30100-ZY4	SCREW-TAPPING	BHT2T 3x10 FE-ZY
	XSTB-40080-ZB8	SCREW-TAPPING	BHT3T 4x8 FE-ZB
	XSTB-40080-ZY8	SCREW-TAPPING	BHT3T 4x8 FE-ZY
	XSTS-30080-ZY4	SCREW-TAPPING	PHWT2T 3x8 FE-ZY
	XSTS-30180-ZY4	SCREW-TAPPING	PHWT2T 3x18 FE-ZY
	YGAP-14860-064	BOX-GIFT	HK3470 535X480X231 DW
	YSAP-12070-002	CUSHION-L/R	EPS
	YVAP-01862-004	POLY-BAG-F	*
	YVAP-13320-004	TOLON-SHEET	750x1200 0.5t
	7JJG-00212-001	PACKING WRAP	500mm*1400m

<b>BLOCK MAIN PCB</b>			
C184	CACS-S472M-179	CAPACITOR AC	DE7100F472M
C134	CCAT-F103Z-AAF	CAPACITOR CERAMIC	0.01uF Z 25V F T
C191	CCAT-F223Z-AAF	CAPACITOR CERAMIC	0.022uF Z 25V F T
C192	CCAT-F223Z-AAF	CAPACITOR CERAMIC	0.022uF Z 25V F T
C101	CCAT-J101K-AAB	CAPACITOR CERAMIC	100PF K 50V B T
C102	CCAT-J101K-AAB	CAPACITOR CERAMIC	100PF K 50V B T
C119	CCAT-J101K-AAB	CAPACITOR CERAMIC	100PF K 50V B T
C120	CCAT-J101K-AAB	CAPACITOR CERAMIC	100PF K 50V B T
C158	CCAT-J101K-AAB	CAPACITOR CERAMIC	100PF K 50V B T
C141	CCAT-J102K-AAB	CAPACITOR CERAMIC	1000PF K 50V B T
C142	CCAT-J102K-AAB	CAPACITOR CERAMIC	1000PF K 50V B T
C175	CCAT-J102K-AAB	CAPACITOR CERAMIC	1000PF K 50V B T
C176	CCAT-J102K-AAB	CAPACITOR CERAMIC	1000PF K 50V B T
C190	CCAT-J104Z-AAF	CAPACITOR CERAMIC	0.1uF Z 50V F T
C202	CCAT-J104Z-AAF	CAPACITOR CERAMIC	0.1uF Z 50V F T
C135	CCAT-J473Z-AAF	CAPACITOR CERAMIC	0.047uF Z 50V F T
C136	CCAT-J473Z-AAF	CAPACITOR CERAMIC	0.047uF Z 50V F T
C137	CCAT-J473Z-AAF	CAPACITOR CERAMIC	0.047uF Z 50V F T
C196	CCCT-J104Z-OFF	CAPACITOR CERAMIC	0.1uF Z 50V F T
C206	CEEM-G222M-LR1	CAPACITOR E/ALUMINUM	2200uF M 35V 16x31.5 U M
C207	CEEM-G222M-LR1	CAPACITOR E/ALUMINUM	2200uF M 35V 16x31.5 U M
C143	CEET-D101M-C10	CAPACITOR E/ALUMINUM	100uF M 10V 5x11 T
C144	CEET-D101M-C10	CAPACITOR E/ALUMINUM	100uF M 10V 5x11 T
C200	CEET-E471M-FI1	CAPACITOR E/ALUMINUM	470uF M 16V 8x11.5 U T
C188	CEET-F102M-HN0	CAPACITOR E/ALUMINUM	1000uF M 25V 13x16 T
C232	CEET-F220M-C10	CAPACITOR E/ALUMINUM	22uF M 25V 5x11 T
C153	CEET-F470M-C10	CAPACITOR E/ALUMINUM	47uF M 25V 5x11 T

Ref. No.	Part No.	Description				
<b>BLOCK MAIN PCB</b>						
C154	CEET-F470M-CI0	CAPACITOR E/ALUMINUM	47uF	M	25V 5x11	T
C155	CEET-F470M-CI0	CAPACITOR E/ALUMINUM	47uF	M	25V 5x11	T
C156	CEET-F470M-CI0	CAPACITOR E/ALUMINUM	47uF	M	25V 5x11	T
C161	CEET-F470M-CI0	CAPACITOR E/ALUMINUM	47uF	M	25V 5x11	T
C162	CEET-F470M-CI0	CAPACITOR E/ALUMINUM	47uF	M	25V 5x11	T
C163	CEET-F470M-CI0	CAPACITOR E/ALUMINUM	47uF	M	25V 5x11	T
C164	CEET-F470M-CI0	CAPACITOR E/ALUMINUM	47uF	M	25V 5x11	T
C167	CEET-F470M-CI0	CAPACITOR E/ALUMINUM	47uF	M	25V 5x11	T
C168	CEET-F470M-CI0	CAPACITOR E/ALUMINUM	47uF	M	25V 5x11	T
C169	CEET-F470M-CI0	CAPACITOR E/ALUMINUM	47uF	M	25V 5x11	T
C170	CEET-F470M-CI0	CAPACITOR E/ALUMINUM	47uF	M	25V 5x11	T
C179	CEET-F470M-CI0	CAPACITOR E/ALUMINUM	47uF	M	25V 5x11	T
C180	CEET-F470M-CI0	CAPACITOR E/ALUMINUM	47uF	M	25V 5x11	T
C210	CEET-G221M-HJ1	CAPACITOR E/ALUMINUM	220uF	M	35V 10x12.5	U T
C157	CEET-J1R0M-CI0	CAPACITOR E/ALUMINUM	1.0uF	M	50V 5x11	T
C181	CEET-J1R0M-CI0	CAPACITOR E/ALUMINUM	1.0uF	M	50V 5x11	T
C183	CEET-J1R0M-CI0	CAPACITOR E/ALUMINUM	1.0uF	M	50V 5x11	T
C189	CEET-J1R0M-CI0	CAPACITOR E/ALUMINUM	1.0uF	M	50V 5x11	T
C201	CEET-J1R0M-CI0	CAPACITOR E/ALUMINUM	1.0uF	M	50V 5x11	T
C208	CEET-J1R0M-CI0	CAPACITOR E/ALUMINUM	1.0uF	M	50V 5x11	T
C209	CEET-J1R0M-CI0	CAPACITOR E/ALUMINUM	1.0uF	M	50V 5x11	T
C218	CEET-J1R0M-CI0	CAPACITOR E/ALUMINUM	1.0uF	M	50V 5x11	T
C219	CEET-J1R0M-CI0	CAPACITOR E/ALUMINUM	1.0uF	M	50V 5x11	T
C120	CEET-J221M-HL1	CAPACITOR E/ALUMINUM	220uF	M	50V 10x16	U T
C193	CEET-J221M-HL1	CAPACITOR E/ALUMINUM	220uF	M	50V 10x16	U T
C139	CEET-J4R7M-CI0	CAPACITOR E/ALUMINUM	4.7uF	M	50V 5x11	T
C140	CEET-J4R7M-CI0	CAPACITOR E/ALUMINUM	4.7uF	M	50V 5x11	T
C149	CEET-J4R7M-CI0	CAPACITOR E/ALUMINUM	4.7uF	M	50V 5x11	T
C150	CEET-J4R7M-CI0	CAPACITOR E/ALUMINUM	4.7uF	M	50V 5x11	T
C159	CEET-J4R7M-CI0	CAPACITOR E/ALUMINUM	4.7uF	M	50V 5x11	T
C160	CEET-J4R7M-CI0	CAPACITOR E/ALUMINUM	4.7uF	M	50V 5x11	T
C165	CEET-J4R7M-CI0	CAPACITOR E/ALUMINUM	4.7uF	M	50V 5x11	T
C166	CEET-J4R7M-CI0	CAPACITOR E/ALUMINUM	4.7uF	M	50V 5x11	T
C171	CEET-J4R7M-CI0	CAPACITOR E/ALUMINUM	4.7uF	M	50V 5x11	T
C172	CEET-J4R7M-CI0	CAPACITOR E/ALUMINUM	4.7uF	M	50V 5x11	T
C173	CEET-J4R7M-CI0	CAPACITOR E/ALUMINUM	4.7uF	M	50V 5x11	T
C174	CEET-J4R7M-CI0	CAPACITOR E/ALUMINUM	4.7uF	M	50V 5x11	T
C177	CEET-J4R7M-CI0	CAPACITOR E/ALUMINUM	4.7uF	M	50V 5x11	T
C178	CEET-J4R7M-CI0	CAPACITOR E/ALUMINUM	4.7uF	M	50V 5x11	T
C194	CEET-J470M-DI0	CAPACITOR E/ALUMINUM	47uF	M	50V 6.3x11	T
C195	CEET-J470M-DI0	CAPACITOR E/ALUMINUM	47uF	M	50V 6.3x11	T
C216	CEEZ-L154M-SW2	CAPACITOR E/ALUMINUM	15000uF	M	63V 35x60	
C217	CEEZ-L154M-SW2	CAPACITOR E/ALUMINUM	15000uF	M	63V 35x60	
C138	CFMT-L334J-EGN	CAPACITOR F/POLYESTR	EB 0.33uF	J	50V 7.2x9.5	T
C197	CFMT-N103J-DE0	CAPACITOR F/POLYESTR	0.01uF	J	100V 6x7	T
C198	CFMT-N103J-DE0	CAPACITOR F/POLYESTR	0.01uF	J	100V 6x7	T
C199	CFMT-N103J-DE0	CAPACITOR F/POLYESTR	0.01uF	J	100V 6x7	T
C203	CFMT-N103J-DE0	CAPACITOR F/POLYESTR	0.01uF	J	100V 6x7	T
C204	CFMT-N103J-DE0	CAPACITOR F/POLYESTR	0.01uF	J	100V 6x7	T
C205	CFMT-N103J-DE0	CAPACITOR F/POLYESTR	0.01uF	J	100V 6x7	T
C145	CFMT-N152J-CJ0	CAPACITOR F/POLYESTR	0.0015uF	J	100V 5.4x12	T
C146	CFMT-N152J-CJ0	CAPACITOR F/POLYESTR	0.0015uF	J	100V 5.4x12	T
C151	CFMT-N182J-CJ0	CAPACITOR F/POLYESTR	0.0018uF	J	100V 5.5x12	T
C152	CFMT-N182J-CJ0	CAPACITOR F/POLYESTR	0.0018uF	J	100V 5.5x12	T
C185	CFMT-N473J-GK0	CAPACITOR F/POLYESTR	0.047uF	J	100V 8.9x13.	T

Ref. No.	Part No.	Description	
<b>BLOCK MAIN PCB</b>			
C186	CFMT-N473J-GK0	CAPACITOR F/POLYESTR	0.047uF J 100V 8.9x13. T
C187	CFMT-N473J-GK0	CAPACITOR F/POLYESTR	0.047uF J 100V 8.9x13. T
C220	CFMT-N473J-GK0	CAPACITOR F/POLYESTR	0.047uF J 100V 8.9x13. T
C221	CFMT-N473J-GK0	CAPACITOR F/POLYESTR	0.047uF J 100V 8.9x13. T
C222	CFMT-N473J-GK0	CAPACITOR F/POLYESTR	0.047uF J 100V 8.9x13. T
C223	CFMT-N473J-GK0	CAPACITOR F/POLYESTR	0.047uF J 100V 8.9x13. T
C147	CFMT-N562J-DJ0	CAPACITOR F/POLYESTR	0.0056uF J 100V 5.8x12 T
C148	CFMT-N562J-DJ0	CAPACITOR F/POLYESTR	0.0056uF J 100V 5.8x12 T
C211	CFMT-S104K-GI0	CAPACITOR F/POLYESTR	0.1uF K 250V 9.5x11 TL
C212	CFMT-S104K-GI0	CAPACITOR F/POLYESTR	0.1uF K 250V 9.5x11 TL
C213	CFMT-S104K-GI0	CAPACITOR F/POLYESTR	0.1uF K 250V 9.5x11 TL
C214	CFMT-S104K-GI0	CAPACITOR F/POLYESTR	0.1uF K 250V 9.5x11 TL
C215	CFMT-S104K-GI0	CAPACITOR F/POLYESTR	0.1uF K 250V 9.5x11 TL
D101	DDMR-00230-T10	DIODE-RECTIFIER	GP60-04F(400V 6A)
D102	DDMR-00230-T10	DIODE-RECTIFIER	GP60-04F(400V 6A)
D103	DDMR-00230-T10	DIODE-RECTIFIER	GP60-04F(400V 6A)
D104	DDMR-00230-T10	DIODE-RECTIFIER	GP60-04F(400V 6A)
D105	DDTR-00040-T10	DIODE-RECTIFIER	1N4004S(400V 1A 0.6mm) T
D106	DDTR-00040-T10	DIODE-RECTIFIER	1N4004S(400V 1A 0.6mm) T
D107	DDTR-00040-T10	DIODE-RECTIFIER	1N4004S(400V 1A 0.6mm) T
D108	DDTR-00040-T10	DIODE-RECTIFIER	1N4004S(400V 1A 0.6mm) T
D109	DDTR-00040-T10	DIODE-RECTIFIER	1N4004S(400V 1A 0.6mm) T
D110	DDTR-00040-T10	DIODE-RECTIFIER	1N4004S(400V 1A 0.6mm) T
D113	DDTR-00040-T10	DIODE-RECTIFIER	1N4004S(400V 1A 0.6mm) T
D114	DDTR-00040-T10	DIODE-RECTIFIER	1N4004S(400V 1A 0.6mm) T
D115	DDTR-00040-T10	DIODE-RECTIFIER	1N4004S(400V 1A 0.6mm) T
D116	DDTR-00040-T10	DIODE-RECTIFIER	1N4004S(400V 1A 0.6mm) T
D117	DDTR-00040-T10	DIODE-RECTIFIER	1N4004S(400V 1A 0.6mm) T
D118	DDTR-00040-T10	DIODE-RECTIFIER	1N4004S(400V 1A 0.6mm) T
D119	DDTR-00040-T10	DIODE-RECTIFIER	1N4004S(400V 1A 0.6mm) T
D120	DDTR-00040-T10	DIODE-RECTIFIER	1N4004S(400V 1A 0.6mm) T
D121	DDTR-00040-T10	DIODE-RECTIFIER	1N4004S(400V 1A 0.6mm) T
D122	DDTR-00040-T10	DIODE-RECTIFIER	1N4004S(400V 1A 0.6mm) T
D125	DDTR-00040-T10	DIODE-RECTIFIER	1N4004S(400V 1A 0.6mm) T
D126	DDTR-00040-T10	DIODE-RECTIFIER	1N4004S(400V 1A 0.6mm) T
D123	DDTS-00070-SO0	DIODE-SI	1SS133 (40V 0.11A) DO-40 T
D124	DDTS-00070-SO0	DIODE-SI	1SS133 (40V 0.11A) DO-40 T
D111	DDTZ-G150C-SO0	DIODE ZENER	MTZ15C 14.35-15.09 DO40 T
D112	DDTZ-G180C-SO0	DIODE ZENER	MTZ18C 17.42-18.33 DO40 T
RL101	ESRY-00340-112	RELAY	SDT-S-112DMR
RL104	ESRY-00350-121	RELAY	V23105-A5003-A201
RL102	ESRY-00370-24U	RELAY	OSA-SS-224DM3(24V DC)
RL103	ESRY-00370-24U	RELAY	OSA-SS-224DM3(24V DC)
IC102	ICDG-00260-S10	IC FUNCTION SELECTOR	LC7821 DIP30S
IC104	ICOP-00131-SE0	IC DUAL OP AMP	KA4558C DIP8
IC105	ICOP-00131-SE0	IC DUAL OP AMP	KA4558C DIP8
IC106	ICOP-00131-SE0	IC DUAL OP AMP	KA4558C DIP8
IC107	ICOP-00131-SE0	IC DUAL OP AMP	KA4558C DIP8
IC101	ICOP-00432-SG0	IC OP AMP	NJM2068DD DIP8
IC103	ICOP-00432-SG0	IC OP AMP	NJM2068DD DIP8
IC108	ICPC-00010-TB0	IC PHOTOCOUPLER	LTV817B DIP4
IC109	ICRG-00043-SE0	IC REGULATOR	KA7805 5V 3mm TO-220
IC110	ICRG-00043-SE0	IC REGULATOR	KA7805 5V 3mm TO-220
IC111	ICRG-00061-SE0	IC REGULATOR	KA7815 15V 3mm TO-220
IC112	ICRG-00251-SE0	IC REGULATOR	KA7915 15V 3mm TO-220



Ref. No.	Part No.	Description	
<b>BLOCK MAIN PCB</b>			
L101	K10T-4470K-003	COIL-INDUCTOR	47uH K LAL02 T
L102	K10T-4470K-003	COIL-INDUCTOR	47uH K LAL02 T
CN107	KNCW-00140-ATM	CONNECTOR-WAFER	5267-10A 2.5mm MILK
CN106	KNCW-00140-3TM	CONNECTOR-WAFER	5267-03A 2.5mm MILK
CN105	KNCW-00140-6TM	CONNECTOR-WAFER	5267-06A 2.5mm MILK
CN113	KNCW-00140-7TM	CONNECTOR-WAFER	5267-07A 2.5mm MILK
CN109	KNCW-00240-AT9	CONNECTOR-WAFER	53014-10 2.0mm WHT
CN108	KNCW-00240-4T9	CONNECTOR-WAFER	53014-04 2.0mm WHT
CN115	KNCW-00823-KT9	CONNECTOR WAFER	6216-20PST
CN111	KNCW-00970-2T9	CONNECTOR-WAFER	JE202-1T-2P
CN112	KNCW-00970-2T9	CONNECTOR-WAFER	JE202-1T-2P
CN104	KNCW-00970-3T9	CONNECTOR-WAFER	JE202-1T-3P
CN101	KNCW-00990-2T9	CONNECTOR-WAFER	JE202A-1T-02
CN102	KNCW-00990-2T9	CONNECTOR-WAFER	JE202A-1T-02
CN103	KNCW-00990-2T9	CONNECTOR-WAFER	JE202A-1T-02
CN114	KNCW-01520-ES9	CONNECTOR-WAFER	35336-1410 20MM 14P
	MEAC-08215-004	RADIATOR-TR	
	MEAC-12693-004	HEAT-SINK(TR)	
GT101	MPAC-03810-004	TERMINAL-GND	ET-HD T0.3
GT102	MPAC-03810-004	TERMINAL-GND	ET-HD T0.3
GT103	MPAC-03810-004	TERMINAL-GND	ET-HD T0.3
FC101	MPAC-11620-004	FUSE CLIP	5.2Pi TAPPING TYPE
FC102	MPAC-11620-004	FUSE CLIP	5.2Pi TAPPING TYPE
FC103	MPAC-11620-004	FUSE CLIP	5.2Pi TAPPING TYPE
FC104	MPAC-11620-004	FUSE CLIP	5.2Pi TAPPING TYPE
FC107	MPAC-11620-004	FUSE CLIP	5.2Pi TAPPING TYPE
FC108	MPAC-11620-004	FUSE CLIP	5.2Pi TAPPING TYPE
FC109	MPAC-11620-004	FUSE CLIP	5.2Pi TAPPING TYPE
FC110	MPAC-11620-004	FUSE CLIP	5.2Pi TAPPING TYPE
FC111	MPAC-11620-004	FUSE CLIP	5.2Pi TAPPING TYPE
FC112	MPAC-11620-004	FUSE CLIP	5.2Pi TAPPING TYPE
PCB1	PCSR-05390-11B	PCB-SINGLE	A1R-539 330x247x1.6t
PT101	PTA1-03680-CJU	TRANSFORMER-POWER	A28-368C-U
R226	RCFT-E101J-000	RESISTOR-CARBON FILM	100ohm 1/5W 5% T
R101	RCFT-E102J-000	RESISTOR-CARBON FILM	1Kohm 1/5W 5% T
R102	RCFT-E102J-000	RESISTOR-CARBON FILM	1Kohm 1/5W 5% T
R138	RCFT-E102J-000	RESISTOR-CARBON FILM	1Kohm 1/5W 5% T
R139	RCFT-E102J-000	RESISTOR-CARBON FILM	1Kohm 1/5W 5% T
R140	RCFT-E102J-000	RESISTOR-CARBON FILM	1Kohm 1/5W 5% T
R149	RCFT-E102J-000	RESISTOR-CARBON FILM	1Kohm 1/5W 5% T
R153	RCFT-E102J-000	RESISTOR-CARBON FILM	1Kohm 1/5W 5% T
R154	RCFT-E102J-000	RESISTOR-CARBON FILM	1Kohm 1/5W 5% T
R159	RCFT-E102J-000	RESISTOR-CARBON FILM	1Kohm 1/5W 5% T
R160	RCFT-E102J-000	RESISTOR-CARBON FILM	1Kohm 1/5W 5% T
R179	RCFT-E102J-000	RESISTOR-CARBON FILM	1Kohm 1/5W 5% T
R191	RCFT-E102J-000	RESISTOR-CARBON FILM	1Kohm 1/5W 5% T
R199	RCFT-E102J-000	RESISTOR-CARBON FILM	1Kohm 1/5W 5% T
R240	RCFT-E102J-000	RESISTOR-CARBON FILM	1Kohm 1/5W 5% T
R147	RCFT-E103J-000	RESISTOR-CARBON FILM	10Kohm 1/5W 5% T
R148	RCFT-E103J-000	RESISTOR-CARBON FILM	10Kohm 1/5W 5% T
R167	RCFT-E103J-000	RESISTOR-CARBON FILM	10Kohm 1/5W 5% T
R169	RCFT-E103J-000	RESISTOR-CARBON FILM	10Kohm 1/5W 5% T
R170	RCFT-E103J-000	RESISTOR-CARBON FILM	10Kohm 1/5W 5% T
R172	RCFT-E103J-000	RESISTOR-CARBON FILM	10Kohm 1/5W 5% T
R177	RCFT-E103J-000	RESISTOR-CARBON FILM	10Kohm 1/5W 5% T

Ref. No.	Part No.	Description	
<b>BLOCK MAIN PCB</b>			
R178	RCFT-E103J-000	RESISTOR-CARBON FILM	10Kohm 1/5W 5% T
R239	RCFT-E103J-000	RESISTOR-CARBON FILM	10Kohm 1/5W 5% T
R119	RCFT-E104J-000	RESISTOR-CARBON FILM	100Kohm 1/5W 5% T
R120	RCFT-E104J-000	RESISTOR-CARBON FILM	100Kohm 1/5W 5% T
R121	RCFT-E104J-000	RESISTOR-CARBON FILM	100Kohm 1/5W 5% T
R122	RCFT-E104J-000	RESISTOR-CARBON FILM	100Kohm 1/5W 5% T
R131	RCFT-E104J-000	RESISTOR-CARBON FILM	100Kohm 1/5W 5% T
R132	RCFT-E104J-000	RESISTOR-CARBON FILM	100Kohm 1/5W 5% T
R137	RCFT-E104J-000	RESISTOR-CARBON FILM	100Kohm 1/5W 5% T
R145	RCFT-E104J-000	RESISTOR-CARBON FILM	100Kohm 1/5W 5% T
R146	RCFT-E104J-000	RESISTOR-CARBON FILM	100Kohm 1/5W 5% T
R157	RCFT-E104J-000	RESISTOR-CARBON FILM	100Kohm 1/5W 5% T
R158	RCFT-E104J-000	RESISTOR-CARBON FILM	100Kohm 1/5W 5% T
R163	RCFT-E104J-000	RESISTOR-CARBON FILM	100Kohm 1/5W 5% T
R164	RCFT-E104J-000	RESISTOR-CARBON FILM	100Kohm 1/5W 5% T
R190	RCFT-E104J-000	RESISTOR-CARBON FILM	100Kohm 1/5W 5% T
R198	RCFT-E104J-000	RESISTOR-CARBON FILM	100Kohm 1/5W 5% T
R203	RCFT-E104J-000	RESISTOR-CARBON FILM	100Kohm 1/5W 5% T
R204	RCFT-E104J-000	RESISTOR-CARBON FILM	100Kohm 1/5W 5% T
R207	RCFT-E104J-000	RESISTOR-CARBON FILM	100Kohm 1/5W 5% T
R208	RCFT-E104J-000	RESISTOR-CARBON FILM	100Kohm 1/5W 5% T
R213	RCFT-E104J-000	RESISTOR-CARBON FILM	100Kohm 1/5W 5% T
R214	RCFT-E104J-000	RESISTOR-CARBON FILM	100Kohm 1/5W 5% T
R221	RCFT-E123J-000	RESISTOR-CARBON FILM	12Kohm 1/5W 5% T
R174	RCFT-E151J-000	RESISTOR-CARBON FILM	150ohm 1/5W 5% T
R215	RCFT-E152J-000	RESISTOR-CARBON FILM	1.5Kohm 1/5W 5% T
R216	RCFT-E152J-000	RESISTOR-CARBON FILM	1.5Kohm 1/5W 5% T
R173	RCFT-E202J-000	RESISTOR-CARBON FILM	2Kohm 1/5W 5% T
R209	RCFT-E202J-000	RESISTOR-CARBON FILM	2Kohm 1/5W 5% T
R210	RCFT-E202J-000	RESISTOR-CARBON FILM	2Kohm 1/5W 5% T
R180	RCFT-E220J-000	RESISTOR-CARBON FILM	22ohm 1/5W 5% T
R181	RCFT-E220J-000	RESISTOR-CARBON FILM	22ohm 1/5W 5% T
R115	RCFT-E221J-000	RESISTOR-CARBON FILM	220ohm 1/5W 5% T
R116	RCFT-E221J-000	RESISTOR-CARBON FILM	220ohm 1/5W 5% T
R117	RCFT-E221J-000	RESISTOR-CARBON FILM	220ohm 1/5W 5% T
R118	RCFT-E221J-000	RESISTOR-CARBON FILM	220ohm 1/5W 5% T
R133	RCFT-E221J-000	RESISTOR-CARBON FILM	220ohm 1/5W 5% T
R134	RCFT-E221J-000	RESISTOR-CARBON FILM	220ohm 1/5W 5% T
R135	RCFT-E221J-000	RESISTOR-CARBON FILM	220ohm 1/5W 5% T
R136	RCFT-E221J-000	RESISTOR-CARBON FILM	220ohm 1/5W 5% T
R155	RCFT-E221J-000	RESISTOR-CARBON FILM	220ohm 1/5W 5% T
R156	RCFT-E221J-000	RESISTOR-CARBON FILM	220ohm 1/5W 5% T
R165	RCFT-E221J-000	RESISTOR-CARBON FILM	220ohm 1/5W 5% T
R166	RCFT-E221J-000	RESISTOR-CARBON FILM	220ohm 1/5W 5% T
R202	RCFT-E221J-000	RESISTOR-CARBON FILM	220ohm 1/5W 5% T
R217	RCFT-E221J-000	RESISTOR-CARBON FILM	220ohm 1/5W 5% T
R218	RCFT-E221J-000	RESISTOR-CARBON FILM	220ohm 1/5W 5% T
R200	RCFT-E222J-000	RESISTOR-CARBON FILM	2.2Kohm 1/5W 5% T
R211	RCFT-E222J-000	RESISTOR-CARBON FILM	2.2Kohm 1/5W 5% T
R212	RCFT-E222J-000	RESISTOR-CARBON FILM	2.2Kohm 1/5W 5% T
R230	RCFT-E222J-000	RESISTOR-CARBON FILM	2.2Kohm 1/5W 5% T
R232	RCFT-E222J-000	RESISTOR-CARBON FILM	2.2Kohm 1/5W 5% T
R243	RCFT-E222J-000	RESISTOR-CARBON FILM	2.2Kohm 1/5W 5% T
R244	RCFT-E222J-000	RESISTOR-CARBON FILM	2.2Kohm 1/5W 5% T
R151	RCFT-E224J-000	RESISTOR-CARBON FILM	220Kohm 1/5W 5% T

Ref. No.	Part No.	Description	
<b>BLOCK MAIN PCB</b>			
R152	RCFT-E224J-000	RESISTOR-CARBON FILM	220Kohm 1/5W 5% T
R183	RCFT-E271J-000	RESISTOR-CARBON FILM	270ohm 1/5W 5% T
R185	RCFT-E271J-000	RESISTOR-CARBON FILM	270ohm 1/5W 5% T
R187	RCFT-E271J-000	RESISTOR-CARBON FILM	270ohm 1/5W 5% T
R189	RCFT-E271J-000	RESISTOR-CARBON FILM	270ohm 1/5W 5% T
R193	RCFT-E271J-000	RESISTOR-CARBON FILM	270ohm 1/5W 5% T
R195	RCFT-E271J-000	RESISTOR-CARBON FILM	270ohm 1/5W 5% T
R197	RCFT-E271J-000	RESISTOR-CARBON FILM	270ohm 1/5W 5% T
R225	RCFT-E271J-000	RESISTOR-CARBON FILM	270ohm 1/5W 5% T
R235	RCFT-E3R3J-000	RESISTOR-CARBON FILM	3.3ohm 1/5W 5% T
R236	RCFT-E3R3J-000	RESISTOR-CARBON FILM	3.3ohm 1/5W 5% T
R222	RCFT-E332J-000	RESISTOR-CARBON FILM	3.3Kohm 1/5W 5% T
R223	RCFT-E332J-000	RESISTOR-CARBON FILM	3.3Kohm 1/5W 5% T
R224	RCFT-E332J-000	RESISTOR-CARBON FILM	3.3Kohm 1/5W 5% T
R161	RCFT-E392J-000	RESISTOR-CARBON FILM	3.9Kohm 1/5W 5% T
R162	RCFT-E392J-000	RESISTOR-CARBON FILM	3.9Kohm 1/5W 5% T
R227	RCFT-E392J-000	RESISTOR-CARBON FILM	3.9Kohm 1/5W 5% T
R176	RCFT-E4R7J-000	RESISTOR-CARBON FILM	4.7ohm 1/5W 5% T
R248	RCFT-E4R7J-000	RESISTOR-CARBON FILM	4.7ohm 1/5W 5% T
R228	RCFT-E470J-000	RESISTOR-CARBON FILM	47ohm 1/5W 5% T
R103	RCFT-E471J-000	RESISTOR-CARBON FILM	470ohm 1/5W 5% T
R104	RCFT-E471J-000	RESISTOR-CARBON FILM	470ohm 1/5W 5% T
R105	RCFT-E471J-000	RESISTOR-CARBON FILM	470ohm 1/5W 5% T
R106	RCFT-E471J-000	RESISTOR-CARBON FILM	470ohm 1/5W 5% T
R107	RCFT-E471J-000	RESISTOR-CARBON FILM	470ohm 1/5W 5% T
R108	RCFT-E471J-000	RESISTOR-CARBON FILM	470ohm 1/5W 5% T
R109	RCFT-E471J-000	RESISTOR-CARBON FILM	470ohm 1/5W 5% T
R110	RCFT-E471J-000	RESISTOR-CARBON FILM	470ohm 1/5W 5% T
R111	RCFT-E471J-000	RESISTOR-CARBON FILM	470ohm 1/5W 5% T
R112	RCFT-E471J-000	RESISTOR-CARBON FILM	470ohm 1/5W 5% T
R113	RCFT-E471J-000	RESISTOR-CARBON FILM	470ohm 1/5W 5% T
R114	RCFT-E471J-000	RESISTOR-CARBON FILM	470ohm 1/5W 5% T
R129	RCFT-E471J-000	RESISTOR-CARBON FILM	470ohm 1/5W 5% T
R130	RCFT-E471J-000	RESISTOR-CARBON FILM	470ohm 1/5W 5% T
R143	RCFT-E471J-000	RESISTOR-CARBON FILM	470ohm 1/5W 5% T
R144	RCFT-E471J-000	RESISTOR-CARBON FILM	470ohm 1/5W 5% T
R205	RCFT-E471J-000	RESISTOR-CARBON FILM	470ohm 1/5W 5% T
R206	RCFT-E471J-000	RESISTOR-CARBON FILM	470ohm 1/5W 5% T
R127	RCFT-E473J-000	RESISTOR-CARBON FILM	47Kohm 1/5W 5% T
R128	RCFT-E473J-000	RESISTOR-CARBON FILM	47Kohm 1/5W 5% T
R141	RCFT-E473J-000	RESISTOR-CARBON FILM	47Kohm 1/5W 5% T
R142	RCFT-E473J-000	RESISTOR-CARBON FILM	47Kohm 1/5W 5% T
R229	RCFT-E473J-000	RESISTOR-CARBON FILM	47Kohm 1/5W 5% T
R182	RCFT-E512J-000	RESISTOR-CARBON FILM	5.1Kohm 1/5W 5% T
R184	RCFT-E512J-000	RESISTOR-CARBON FILM	5.1Kohm 1/5W 5% T
R186	RCFT-E512J-000	RESISTOR-CARBON FILM	5.1Kohm 1/5W 5% T
R188	RCFT-E512J-000	RESISTOR-CARBON FILM	5.1Kohm 1/5W 5% T
R192	RCFT-E512J-000	RESISTOR-CARBON FILM	5.1Kohm 1/5W 5% T
R194	RCFT-E512J-000	RESISTOR-CARBON FILM	5.1Kohm 1/5W 5% T
R196	RCFT-E512J-000	RESISTOR-CARBON FILM	5.1Kohm 1/5W 5% T
R125	RCFT-E564J-000	RESISTOR-CARBON FILM	560Kohm 1/5W 5% T
R126	RCFT-E564J-000	RESISTOR-CARBON FILM	560Kohm 1/5W 5% T
R168	RCFT-E622J-000	RESISTOR-CARBON FILM	6.2Kohm 1/5W 5% T
R171	RCFT-E622J-000	RESISTOR-CARBON FILM	6.2Kohm 1/5W 5% T
R123	RCFT-E751J-000	RESISTOR-CARBON FILM	750ohm 1/5W 5% T

Ref. No.	Part No.	Description	
<b>BLOCK MAIN PCB</b>			
R124	RCFT-E751J-000	RESISTOR-CARBON FILM	750ohm 1/5W 5% T
R175	RCFT-E820J-000	RESISTOR-CARBON FILM	82ohm 1/5W 5% T
R201	RCFT-E823J-000	RESISTOR-CARBON FILM	82Kohm 1/5W 5% T
R231	RCFT-E823J-000	RESISTOR-CARBON FILM	82Kohm 1/5W 5% T
R245	RCFT-E823J-000	RESISTOR-CARBON FILM	82Kohm 1/5W 5% T
R246	RCFT-E823J-000	RESISTOR-CARBON FILM	82Kohm 1/5W 5% T
R237	RCFT-F4R7J-010	RESISTOR-CARBON FILM	4.7ohm 1/4W 5% T
R238	RCFT-F4R7J-010	RESISTOR-CARBON FILM	4.7ohm 1/4W 5% T
R247	RCFT-F4R7J-010	RESISTOR-CARBON FILM	4.7ohm 1/4W 5% T
R234	RCFT-G335K-1D0	RESISTOR-CARBON FILM	3.3Mohm 1/2W ERC12UGK33
R253	RMOH-H100J-100	RESISTOR-METAL OXIDE	PRO1 1W 10ohm 5% R-SHAP
R233	RMOH-H4R7J-100	RESISTOR-METAL OXIDE	PRO1 1W 4.7ohm J R-SHAPE
R241	RMOH-H4R7J-100	RESISTOR-METAL OXIDE	PRO1 1W 4.7ohm J R-SHAPE
R242	RMOH-H4R7J-100	RESISTOR-METAL OXIDE	PRO1 1W 4.7ohm J R-SHAPE
R249	RMOH-J100J-040	RESISTOR-METAL OXIDE	10ohm 2W 5% H
R250	RMOH-J100J-040	RESISTOR-METAL OXIDE	10ohm 2W 5% H
R251	RMOH-J100J-040	RESISTOR-METAL OXIDE	10ohm 2W 5% H
R252	RMOH-J100J-040	RESISTOR-METAL OXIDE	10ohm 2W 5% H
A0101	SKAO-00190-C50	AC OUTLET	S2-764T-214
JK105	SKPH-00520-360	MINIATURE JACK	HSJ1002-01-1020
JK101	SKRC-00290-020	SOCKET-RCA	JK0200440N 2P
JK102	SKRC-00420-061	SOCKET-RCA	JK0600460N
JK103	SKRC-00420-061	SOCKET-RCA	JK0600460N
JK104	SKRC-00760-060	SOCKET-RCA	JK0600467N
TE101	TESP-00230-08S	TERMINAL SPEAKER	SH0810360P
Q102	TRTA-0012Y-SD0	TRANSISTOR P-H FREQ	KTA1273-Y TO92L
Q106	TRTA-00940-SD0	TRANSISTOR P-H FREQ	KRA107M W/RESIST TO92M
Q109	TRTA-00940-SD0	TRANSISTOR P-H FREQ	KRA107M W/RESIST TO92M
Q105	TRTC-01700-SD0	TRANSISTOR N-H FREQ	KRC107M W/RESIST TO92M
Q101	TRTD-00200-SD0	TRANSISTOR N-L FREQ	KTD-1302 TO92
Q103	TRTD-00200-SD0	TRANSISTOR N-L FREQ	KTD-1302 TO92
Q104	TRTD-00200-SD0	TRANSISTOR N-L FREQ	KTD-1302 TO92
Q107	TRTD-00200-SD0	TRANSISTOR N-L FREQ	KTD-1302 TO92
Q108	TRTD-00200-SD0	TRANSISTOR N-L FREQ	KTD-1302 TO92
Q110	TRTD-00200-SD0	TRANSISTOR N-L FREQ	KTD-1302 TO92
Q111	TRTD-00200-SD0	TRANSISTOR N-L FREQ	KTD-1302 TO92
<b>BLOCK FRONT PCB</b>			
C302	CCAT-J104Z-AAF	CAPACITOR CERAMIC	0.1uF Z 50V F T
C305	CCAT-J104Z-AAF	CAPACITOR CERAMIC	0.1uF Z 50V F T
C306	CCAT-J104Z-AAF	CAPACITOR CERAMIC	0.1uF Z 50V F T
C308	CCAT-J104Z-AAF	CAPACITOR CERAMIC	0.1uF Z 50V F T
C314	CCAT-J104Z-AAF	CAPACITOR CERAMIC	0.1uF Z 50V F T
C315	CCAT-J104Z-AAF	CAPACITOR CERAMIC	0.1uF Z 50V F T
C503	CCAT-J330J-AAZ	CAPACITOR CERAMIC	33PF J 50V SL T
C504	CCAT-J330J-AAZ	CAPACITOR CERAMIC	33PF J 50V SL T
C317	CCAT-J470J-AAZ	CAPACITOR CERAMIC	47PF J 50V SL T
C501	CCAT-J470J-AAZ	CAPACITOR CERAMIC	47PF J 50V SL T
C502	CCAT-J470J-AAZ	CAPACITOR CERAMIC	47PF J 50V SL T
C311	CCAT-J473Z-AAF	CAPACITOR CERAMIC	0.047uF Z 50V F T
C312	CCAT-J473Z-AAF	CAPACITOR CERAMIC	0.047uF Z 50V F T
C307	CCCT-J103Z-0DF	CAPACITOR CERAMIC	0.01uF Z 50V F T
C413	CCTT-J120J-0BC	CAPACITOR CERAMIC	12PF J 50V CH T
C414	CCTT-J120J-0BC	CAPACITOR CERAMIC	12PF J 50V CH T
C419	CCTT-J470J-0DC	CAPACITOR CERAMIC	47PF J 50V CH T

Ref. No.	Part No.	Description				
<b>BLOCK FRONT PCB</b>						
C420	CCTT-J470J-ODC	CAPACITOR CERAMIC	47PF	J 50V	CH T	
C403	CCTT-J680J-0FC	CAPACITOR CERAMIC	68PF	J 50V	CH T	
C404	CCTT-J680J-0FC	CAPACITOR CERAMIC	68PF	J 50V	CH T	
C409	CCTT-J681J-0BZ	CAPACITOR CERAMIC	680PF	J 50V	SL T	
C410	CCTT-J681J-0BZ	CAPACITOR CERAMIC	680PF	J 50V	SL T	
C411	CEET-C471M-FI1	CAPACITOR E/ALUMINUM	470uF	M 6.3V	8x11.5	U T
C412	CEET-C471M-FI1	CAPACITOR E/ALUMINUM	470uF	M 6.3V	8x11.5	U T
C428	CEET-C471M-FI1	CAPACITOR E/ALUMINUM	470uF	M 6.3V	8x11.5	U T
C401	CEET-F220M-CI0	CAPACITOR E/ALUMINUM	22uF	M 25V	5x11	T
C402	CEET-F220M-CI0	CAPACITOR E/ALUMINUM	22uF	M 25V	5x11	T
C407	CEET-F220M-CI0	CAPACITOR E/ALUMINUM	22uF	M 25V	5x11	T
C408	CEET-F220M-CI0	CAPACITOR E/ALUMINUM	22uF	M 25V	5x11	T
C405	CEET-F330M-CI0	CAPACITOR E/ALUMINUM	33uF	M 25V	5x11	T
C406	CEET-F330M-CI0	CAPACITOR E/ALUMINUM	33uF	M 25V	5x11	T
C304	CEET-F470M-CI0	CAPACITOR E/ALUMINUM	47uF	M 25V	5x11	T
C316	CEET-F470M-CI0	CAPACITOR E/ALUMINUM	47uF	M 25V	5x11	T
C509	CEET-F470M-CI0	CAPACITOR E/ALUMINUM	47uF	M 25V	5x11	T
C510	CEET-F470M-CI0	CAPACITOR E/ALUMINUM	47uF	M 25V	5x11	T
C303	CEET-JR10M-CI0	CAPACITOR E/ALUMINUM	0.1uF	M 50V	5x11	T
C310	CEET-J1R0M-CI0	CAPACITOR E/ALUMINUM	1.0uF	M 50V	5x11	T
C427	CEET-J1R0M-CI0	CAPACITOR E/ALUMINUM	1.0uF	M 50V	5x11	T
C309	CEET-J100M-CI0	CAPACITOR E/ALUMINUM	10uF	M 50V	5x11	T
C421	CEET-J100M-CI0	CAPACITOR E/ALUMINUM	10uF	M 50V	5x11	T
C422	CEET-J100M-CI0	CAPACITOR E/ALUMINUM	10uF	M 50V	5x11	T
C425	CEET-J100M-CI0	CAPACITOR E/ALUMINUM	10uF	M 50V	5x11	T
C426	CEET-J100M-CI0	CAPACITOR E/ALUMINUM	10uF	M 50V	5x11	T
C505	CEET-J100M-CI0	CAPACITOR E/ALUMINUM	10uF	M 50V	5x11	T
C506	CEET-J100M-CI0	CAPACITOR E/ALUMINUM	10uF	M 50V	5x11	T
C507	CEET-J100M-CI0	CAPACITOR E/ALUMINUM	10uF	M 50V	5x11	T
C508	CEET-J100M-CI0	CAPACITOR E/ALUMINUM	10uF	M 50V	5x11	T
C423	CEET-J4R7M-CI0	CAPACITOR E/ALUMINUM	4.7uF	M 50V	5x11	T
C424	CEET-J4R7M-CI0	CAPACITOR E/ALUMINUM	4.7uF	M 50V	5x11	T
C313	CEET-J470M-DI0	CAPACITOR E/ALUMINUM	47uF	M 50V	6.3x11	T
C415	CEET-L331M-DI1	CAPACITOR E/ALUMINUM	330uF	M 63V	10x20	SHL T
C416	CEET-L331M-DI1	CAPACITOR E/ALUMINUM	330uF	M 63V	10x20	SHL T
C417	CEET-L331M-DI1	CAPACITOR E/ALUMINUM	330uF	M 63V	10x20	SHL T
C418	CEET-L331M-DI1	CAPACITOR E/ALUMINUM	330uF	M 63V	10x20	SHL T
C301	CEGT-B104J-OJ0	CAPACITOR E/DO LAYER	0.1F	J 5.5V	SCDA5R5104A	T
C511	CFMT-N183J-EK0	CAPACITOR F/POLYESTR	0.018uF	J 100V	7.3x13	T
C512	CFMT-N183J-EK0	CAPACITOR F/POLYESTR	0.018uF	J 100V	7.3x13	T
C517	CFMT-N183J-EK0	CAPACITOR F/POLYESTR	0.018uF	J 100V	7.3x13	T
C518	CFMT-N183J-EK0	CAPACITOR F/POLYESTR	0.018uF	J 100V	7.3x13	T
C515	CFMT-N392J-DJ0	CAPACITOR F/POLYESTR	0.0039uF	J 100V	5.8x12	T
C516	CFMT-N392J-DJ0	CAPACITOR F/POLYESTR	0.0039uF	J 100V	5.8x12	T
C513	CFMT-N823J-IK0	CAPACITOR F/POLYESTR	0.082uF	J 100V	10.6x14	T
C514	CFMT-N823J-IK0	CAPACITOR F/POLYESTR	0.082uF	J 100V	10.6x14	T
D301	DDTS-00070-SO0	DIODE-SI	1SS133	(40V 0.11A)	DO-40	T
D302	DDTS-00070-SO0	DIODE-SI	1SS133	(40V 0.11A)	DO-40	T
D303	DDTS-00070-SO0	DIODE-SI	1SS133	(40V 0.11A)	DO-40	T
D304	DDTS-00070-SO0	DIODE-SI	1SS133	(40V 0.11A)	DO-40	T
D306	DDTS-00070-SO0	DIODE-SI	1SS133	(40V 0.11A)	DO-40	T
D307	DDTS-00070-SO0	DIODE-SI	1SS133	(40V 0.11A)	DO-40	T
D308	DDTS-00070-SO0	DIODE-SI	1SS133	(40V 0.11A)	DO-40	T
D309	DDTS-00070-SO0	DIODE-SI	1SS133	(40V 0.11A)	DO-40	T
D310	DDTS-00070-SO0	DIODE-SI	1SS133	(40V 0.11A)	DO-40	T

Ref. No.	Part No.	Description	
<b>BLOCK FRONT PCB</b>			
D311	DDTS-00070-SO0	DIODE-SI	1SS133 (40V 0.11A) DO-40 T
D312	DDTS-00070-SO0	DIODE-SI	1SS133 (40V 0.11A) DO-40 T
D401	DDTS-00070-SO0	DIODE-SI	1SS133 (40V 0.11A) DO-40 T
D402	DDTS-00070-SO0	DIODE-SI	1SS133 (40V 0.11A) DO-40 T
D403	DDTS-00070-SO0	DIODE-SI	1SS133 (40V 0.11A) DO-40 T
D404	DDTS-00070-SO0	DIODE-SI	1SS133 (40V 0.11A) DO-40 T
D405	DDTS-00070-SO0	DIODE-SI	1SS133 (40V 0.11A) DO-40 T
D305	DDTZ-G075B-SO0	DIODE ZENER	MTZ7.5B 7.07-7.45 DO40 T
D406	DDTZ-G091B-SO0	DIODE ZENER	MTZ9.1B 9.01 DO40 T
FL301	DPFL-00780-000	VPD	HNA-16LL15
LD802	DPLE-00210-YG0	DISPLAY-LED	SM3511
LD301	DPLE-00211-GG0	DISPLAY-LED	SM3511(F2T)
LD302	DPLE-00211-GG0	DISPLAY-LED	SM3511(F2T)
LD303	DPLE-00211-GG0	DISPLAY-LED	SM3511(F2T)
LD304	DPLE-00211-GG0	DISPLAY-LED	SM3511(F2T)
LD305	DPLE-00211-GG0	DISPLAY-LED	SM3511(F2T)
LD306	DPLE-00211-GG0	DISPLAY-LED	SM3511(F2T)
LD801	DPLE-00280-RG0	DISPLAY-LED	SAM5270 RED/GRN
IC304	ICCM-01500-SB0	IC MEMORY LSI	BR24C04-W DIP8
IC703	ICHY-00370-U80	IC REMOTE RECEIVER	HI-M602H0
IC301	ICMP-04110-SE0	IC (U-COM)	UPD780204GF-084-3BA
IC303	ICOP-00210-SD0	IC RESET	KIA7042P/F 4.2V TO-92
IC501	ICOP-03150-SG0	IC OP AMP	NJM2068M SOP8
L302	KIBK-00190-E40	COIL-AUDIO CHOCK	0.7uH COIL-CHOCK
L401	KIBK-00190-E40	COIL-AUDIO CHOCK	0.7uH COIL-CHOCK
CN402	KNCW-00140-2TM	CONNECTOR-WAFER	5267-02A 2.5mm MILK
CN401	KNCW-00140-3TM	CONNECTOR-WAFER	5267-03A 2.5mm MILK
CN302	KNCW-00160-5S9	CONNECTOR-WAFER	53015-0510 2mm-WHT
CN301	KNCW-00823-KS9	CONNECTOR WAFER	6216-20PRA
CN801	KNCW-00990-2T9	CONNECTOR-WAFER	JE202A-1T-02
Z301	KTRE-00171-042	RESONATOR	CST4.19MGW-TF01
	MEAC-08212-004	RADIATOR	
	MRAG-13830-004	CUSHION-FL	EVA T=5.0
	MRAG-13840-004	CUSHION-REMOTE	EVA T=11.0
	PCSR-05400-11B	PCB-SINGLE	A1R-540 330x247x1.6t
R319	RCFT-E100J-000	RESISTOR-CARBON FILM	10ohm 1/5W 5% T
R346	RCFT-E100J-000	RESISTOR-CARBON FILM	10ohm 1/5W 5% T
R317	RCFT-E101J-000	RESISTOR-CARBON FILM	100ohm 1/5W 5% T
R318	RCFT-E101J-000	RESISTOR-CARBON FILM	100ohm 1/5W 5% T
R495	RCFT-E102J-000	RESISTOR-CARBON FILM	1Kohm 1/5W 5% T
R304	RCFT-E103J-000	RESISTOR-CARBON FILM	10Kohm 1/5W 5% T
R345	RCFT-E103J-000	RESISTOR-CARBON FILM	10Kohm 1/5W 5% T
R405	RCFT-E103J-000	RESISTOR-CARBON FILM	10Kohm 1/5W 5% T
R406	RCFT-E103J-000	RESISTOR-CARBON FILM	10Kohm 1/5W 5% T
R491	RCFT-E103J-000	RESISTOR-CARBON FILM	10Kohm 1/5W 5% T
R302	RCFT-E104J-000	RESISTOR-CARBON FILM	100Kohm 1/5W 5% T
R305	RCFT-E104J-000	RESISTOR-CARBON FILM	100Kohm 1/5W 5% T
R337	RCFT-E104J-000	RESISTOR-CARBON FILM	100Kohm 1/5W 5% T
R338	RCFT-E104J-000	RESISTOR-CARBON FILM	100Kohm 1/5W 5% T
R339	RCFT-E104J-000	RESISTOR-CARBON FILM	100Kohm 1/5W 5% T
R340	RCFT-E104J-000	RESISTOR-CARBON FILM	100Kohm 1/5W 5% T
R341	RCFT-E104J-000	RESISTOR-CARBON FILM	100Kohm 1/5W 5% T
R342	RCFT-E104J-000	RESISTOR-CARBON FILM	100Kohm 1/5W 5% T
R343	RCFT-E104J-000	RESISTOR-CARBON FILM	100Kohm 1/5W 5% T
R344	RCFT-E104J-000	RESISTOR-CARBON FILM	100Kohm 1/5W 5% T

Ref. No.	Part No.	Description	
<b>BLOCK FRONT PCB</b>			
R488	RCFT-E104J-000	RESISTOR-CARBON FILM	100Kohm 1/5W 5% T
R492	RCFT-E104J-000	RESISTOR-CARBON FILM	100Kohm 1/5W 5% T
R501	RCFT-E104J-000	RESISTOR-CARBON FILM	100Kohm 1/5W 5% T
R502	RCFT-E104J-000	RESISTOR-CARBON FILM	100Kohm 1/5W 5% T
R511	RCFT-E104J-000	RESISTOR-CARBON FILM	100Kohm 1/5W 5% T
R512	RCFT-E104J-000	RESISTOR-CARBON FILM	100Kohm 1/5W 5% T
R306	RCFT-E105J-000	RESISTOR-CARBON FILM	1Mohm 1/5W 5% T
R503	RCFT-E105J-000	RESISTOR-CARBON FILM	1Mohm 1/5W 5% T
R504	RCFT-E105J-000	RESISTOR-CARBON FILM	1Mohm 1/5W 5% T
R425	RCFT-E122J-000	RESISTOR-CARBON FILM	1.2Kohm 1/5W 5% T
R426	RCFT-E122J-000	RESISTOR-CARBON FILM	1.2Kohm 1/5W 5% T
R455	RCFT-E122J-000	RESISTOR-CARBON FILM	1.2Kohm 1/5W 5% T
R456	RCFT-E122J-000	RESISTOR-CARBON FILM	1.2Kohm 1/5W 5% T
R415	RCFT-E150J-000	RESISTOR-CARBON FILM	15ohm 1/5W 5% T
R416	RCFT-E150J-000	RESISTOR-CARBON FILM	15ohm 1/5W 5% T
R417	RCFT-E150J-000	RESISTOR-CARBON FILM	15ohm 1/5W 5% T
R418	RCFT-E150J-000	RESISTOR-CARBON FILM	15ohm 1/5W 5% T
R407	RCFT-E151J-000	RESISTOR-CARBON FILM	150ohm 1/5W 5% T
R408	RCFT-E151J-000	RESISTOR-CARBON FILM	150ohm 1/5W 5% T
R471	RCFT-E152J-000	RESISTOR-CARBON FILM	1.5Kohm 1/5W 5% T
R472	RCFT-E152J-000	RESISTOR-CARBON FILM	1.5Kohm 1/5W 5% T
R490	RCFT-E152J-000	RESISTOR-CARBON FILM	1.5Kohm 1/5W 5% T
R494	RCFT-E153J-000	RESISTOR-CARBON FILM	15Kohm 1/5W 5% T
R320	RCFT-E181J-000	RESISTOR-CARBON FILM	180ohm 1/5W 5% T
R321	RCFT-E181J-000	RESISTOR-CARBON FILM	180ohm 1/5W 5% T
R322	RCFT-E181J-000	RESISTOR-CARBON FILM	180ohm 1/5W 5% T
R323	RCFT-E181J-000	RESISTOR-CARBON FILM	180ohm 1/5W 5% T
R324	RCFT-E181J-000	RESISTOR-CARBON FILM	180ohm 1/5W 5% T
R325	RCFT-E181J-000	RESISTOR-CARBON FILM	180ohm 1/5W 5% T
R469	RCFT-E182J-000	RESISTOR-CARBON FILM	1.8Kohm 1/5W 5% T
R470	RCFT-E182J-000	RESISTOR-CARBON FILM	1.8Kohm 1/5W 5% T
R507	RCFT-E203J-000	RESISTOR-CARBON FILM	20Kohm 1/5W 5% T
R508	RCFT-E203J-000	RESISTOR-CARBON FILM	20Kohm 1/5W 5% T
R519	RCFT-E221J-000	RESISTOR-CARBON FILM	220ohm 1/5W 5% T
R520	RCFT-E221J-000	RESISTOR-CARBON FILM	220ohm 1/5W 5% T
R513	RCFT-E222J-000	RESISTOR-CARBON FILM	2.2Kohm 1/5W 5% T
R514	RCFT-E222J-000	RESISTOR-CARBON FILM	2.2Kohm 1/5W 5% T
R517	RCFT-E222J-000	RESISTOR-CARBON FILM	2.2Kohm 1/5W 5% T
R518	RCFT-E222J-000	RESISTOR-CARBON FILM	2.2Kohm 1/5W 5% T
R301	RCFT-E223J-000	RESISTOR-CARBON FILM	22Kohm 1/5W 5% T
R303	RCFT-E223J-000	RESISTOR-CARBON FILM	22Kohm 1/5W 5% T
R334	RCFT-E223J-000	RESISTOR-CARBON FILM	22Kohm 1/5W 5% T
R335	RCFT-E223J-000	RESISTOR-CARBON FILM	22Kohm 1/5W 5% T
R336	RCFT-E223J-000	RESISTOR-CARBON FILM	22Kohm 1/5W 5% T
R451	RCFT-E223J-000	RESISTOR-CARBON FILM	22Kohm 1/5W 5% T
R452	RCFT-E223J-000	RESISTOR-CARBON FILM	22Kohm 1/5W 5% T
R453	RCFT-E223J-000	RESISTOR-CARBON FILM	22Kohm 1/5W 5% T
R454	RCFT-E223J-000	RESISTOR-CARBON FILM	22Kohm 1/5W 5% T
R493	RCFT-E223J-000	RESISTOR-CARBON FILM	22Kohm 1/5W 5% T
R477	RCFT-E243J-000	RESISTOR-CARBON FILM	24Kohm 1/5W 5% T
R478	RCFT-E243J-000	RESISTOR-CARBON FILM	24Kohm 1/5W 5% T
R313	RCFT-E271J-000	RESISTOR-CARBON FILM	270ohm 1/5W 5% T
R315	RCFT-E271J-000	RESISTOR-CARBON FILM	270ohm 1/5W 5% T
R463	RCFT-E3R3J-000	RESISTOR-CARBON FILM	3.3ohm 1/5W 5% T
R464	RCFT-E3R3J-000	RESISTOR-CARBON FILM	3.3ohm 1/5W 5% T

Ref. No.	Part No.	Description	
<b>BLOCK FRONT PCB</b>			
R465	RCFT-E3R3J-000	RESISTOR-CARBON FILM	3.3ohm 1/5W 5% T
R466	RCFT-E3R3J-000	RESISTOR-CARBON FILM	3.3ohm 1/5W 5% T
R401	RCFT-E331J-000	RESISTOR-CARBON FILM	330ohm 1/5W 5% T
R402	RCFT-E331J-000	RESISTOR-CARBON FILM	330ohm 1/5W 5% T
R489	RCFT-E332J-000	RESISTOR-CARBON FILM	3.3Kohm 1/5W 5% T
R316	RCFT-E333J-000	RESISTOR-CARBON FILM	33Kohm 1/5W 5% T
R403	RCFT-E333J-000	RESISTOR-CARBON FILM	33Kohm 1/5W 5% T
R404	RCFT-E333J-000	RESISTOR-CARBON FILM	33Kohm 1/5W 5% T
R427	RCFT-E333J-000	RESISTOR-CARBON FILM	33Kohm 1/5W 5% T
R428	RCFT-E333J-000	RESISTOR-CARBON FILM	33Kohm 1/5W 5% T
R492	RCFT-E333J-000	RESISTOR-CARBON FILM	33Kohm 1/5W 5% T
R496	RCFT-E333J-000	RESISTOR-CARBON FILM	33Kohm 1/5W 5% T
R497	RCFT-E333J-000	RESISTOR-CARBON FILM	33Kohm 1/5W 5% T
R479	RCFT-E390J-000	RESISTOR-CARBON FILM	39ohm 1/5W 5% T
R480	RCFT-E390J-000	RESISTOR-CARBON FILM	39ohm 1/5W 5% T
R481	RCFT-E390J-000	RESISTOR-CARBON FILM	39ohm 1/5W 5% T
R482	RCFT-E390J-000	RESISTOR-CARBON FILM	39ohm 1/5W 5% T
R483	RCFT-E390J-000	RESISTOR-CARBON FILM	39ohm 1/5W 5% T
R484	RCFT-E390J-000	RESISTOR-CARBON FILM	39ohm 1/5W 5% T
R485	RCFT-E390J-000	RESISTOR-CARBON FILM	39ohm 1/5W 5% T
R486	RCFT-E390J-000	RESISTOR-CARBON FILM	39ohm 1/5W 5% T
R509	RCFT-E432J-000	RESISTOR-CARBON FILM	4.3Kohm 1/5W 5% T
R510	RCFT-E432J-000	RESISTOR-CARBON FILM	4.3Kohm 1/5W 5% T
R505	RCFT-E471J-000	RESISTOR-CARBON FILM	470ohm 1/5W 5% T
R506	RCFT-E471J-000	RESISTOR-CARBON FILM	470ohm 1/5W 5% T
R309	RCFT-E472J-000	RESISTOR-CARBON FILM	4.7Kohm 1/5W 5% T
R310	RCFT-E472J-000	RESISTOR-CARBON FILM	4.7Kohm 1/5W 5% T
R311	RCFT-E472J-000	RESISTOR-CARBON FILM	4.7Kohm 1/5W 5% T
R312	RCFT-E472J-000	RESISTOR-CARBON FILM	4.7Kohm 1/5W 5% T
R441	RCFT-E472J-000	RESISTOR-CARBON FILM	4.7Kohm 1/5W 5% T
R442	RCFT-E472J-000	RESISTOR-CARBON FILM	4.7Kohm 1/5W 5% T
R307	RCFT-E473J-000	RESISTOR-CARBON FILM	47Kohm 1/5W 5% T
R326	RCFT-E473J-000	RESISTOR-CARBON FILM	47Kohm 1/5W 5% T
R327	RCFT-E473J-000	RESISTOR-CARBON FILM	47Kohm 1/5W 5% T
R328	RCFT-E473J-000	RESISTOR-CARBON FILM	47Kohm 1/5W 5% T
R329	RCFT-E473J-000	RESISTOR-CARBON FILM	47Kohm 1/5W 5% T
R331	RCFT-E473J-000	RESISTOR-CARBON FILM	47Kohm 1/5W 5% T
R333	RCFT-E473J-000	RESISTOR-CARBON FILM	47Kohm 1/5W 5% T
R314	RCFT-E561J-000	RESISTOR-CARBON FILM	560ohm 1/5W 5% T
R429	RCFT-E561J-000	RESISTOR-CARBON FILM	560ohm 1/5W 5% T
R430	RCFT-E561J-000	RESISTOR-CARBON FILM	560ohm 1/5W 5% T
R431	RCFT-E561J-000	RESISTOR-CARBON FILM	560ohm 1/5W 5% T
R432	RCFT-E561J-000	RESISTOR-CARBON FILM	560ohm 1/5W 5% T
R433	RCFT-E561J-000	RESISTOR-CARBON FILM	560ohm 1/5W 5% T
R434	RCFT-E561J-000	RESISTOR-CARBON FILM	560ohm 1/5W 5% T
R435	RCFT-E561J-000	RESISTOR-CARBON FILM	560ohm 1/5W 5% T
R436	RCFT-E561J-000	RESISTOR-CARBON FILM	560ohm 1/5W 5% T
R437	RCFT-E561J-000	RESISTOR-CARBON FILM	560ohm 1/5W 5% T
R438	RCFT-E561J-000	RESISTOR-CARBON FILM	560ohm 1/5W 5% T
R439	RCFT-E561J-000	RESISTOR-CARBON FILM	560ohm 1/5W 5% T
R440	RCFT-E561J-000	RESISTOR-CARBON FILM	560ohm 1/5W 5% T
R473	RCFT-E561J-000	RESISTOR-CARBON FILM	560ohm 1/5W 5% T
R474	RCFT-E561J-000	RESISTOR-CARBON FILM	560ohm 1/5W 5% T
R515	RCFT-E561J-000	RESISTOR-CARBON FILM	560ohm 1/5W 5% T
R516	RCFT-E561J-000	RESISTOR-CARBON FILM	560ohm 1/5W 5% T



Ref. No.	Part No.	Description	
<b>BLOCK FRONT PCB</b>			
R409	RCFT-E680J-000	RESISTOR-CARBON FILM	68ohm 1/5W 5% T
R410	RCFT-E680J-000	RESISTOR-CARBON FILM	68ohm 1/5W 5% T
R419	RCFT-E681J-000	RESISTOR-CARBON FILM	680ohm 1/5W 5% T
R420	RCFT-E681J-000	RESISTOR-CARBON FILM	680ohm 1/5W 5% T
R475	RCFT-E682J-000	RESISTOR-CARBON FILM	6.8Kohm 1/5W 5% T
R476	RCFT-E682J-000	RESISTOR-CARBON FILM	6.8Kohm 1/5W 5% T
R487	RCFT-E683J-000	RESISTOR-CARBON FILM	68Kohm 1/5W 5% T
R421	RCFT-E751J-000	RESISTOR-CARBON FILM	750ohm 1/5W 5% T
R422	RCFT-E751J-000	RESISTOR-CARBON FILM	750ohm 1/5W 5% T
R423	RCFT-E751J-000	RESISTOR-CARBON FILM	750ohm 1/5W 5% T
R424	RCFT-E751J-000	RESISTOR-CARBON FILM	750ohm 1/5W 5% T
R443	RCFT-E820J-000	RESISTOR-CARBON FILM	82ohm 1/5W 5% T
R444	RCFT-E820J-000	RESISTOR-CARBON FILM	82ohm 1/5W 5% T
R445	RCFT-E820J-000	RESISTOR-CARBON FILM	82ohm 1/5W 5% T
R446	RCFT-E820J-000	RESISTOR-CARBON FILM	82ohm 1/5W 5% T
R461	RCFT-E820J-000	RESISTOR-CARBON FILM	82ohm 1/5W 5% T
R462	RCFT-E820J-000	RESISTOR-CARBON FILM	82ohm 1/5W 5% T
R457	RCFT-E821J-000	RESISTOR-CARBON FILM	820ohm 1/5W 5% T
R458	RCFT-E821J-000	RESISTOR-CARBON FILM	820ohm 1/5W 5% T
R459	RCFT-E821J-000	RESISTOR-CARBON FILM	820ohm 1/5W 5% T
R460	RCFT-E821J-000	RESISTOR-CARBON FILM	820ohm 1/5W 5% T
	RJWT-00000-AA0	RESISTOR-JUMPER WIRE	60mm-TX123 F
R467	RMFT-LR27J-OJO	RESISTOR-METAL PLATE	0.27ohm 5W 5% MPR
R468	RMFT-LR27J-OJO	RESISTOR-METAL PLATE	0.27ohm 5W 5% MPR
R801	RMOH-J221J-040	RESISTOR-METAL OXIDE	220ohm 2W 5% H
R802	RMOH-J221J-040	RESISTOR-METAL OXIDE	220ohm 2W 5% H
R447	RMOR-H470J-0C0	RESISTOR-METAL OXIDE	47ohm 1W 5% ERG(X)1SJ47C
R448	RMOR-H470J-0C0	RESISTOR-METAL OXIDE	47ohm 1W 5% ERG(X)1SJ47C
R449	RMOR-H470J-0C0	RESISTOR-METAL OXIDE	47ohm 1W 5% ERG(X)1SJ47C
R450	RMOR-H470J-0C0	RESISTOR-METAL OXIDE	47ohm 1W 5% ERG(X)1SJ47C
SW801	SWPU-00591-059	SWITCH-PUSH	SDDL13300
SW301	SWTA-00220-060	SWITCH-TACT	THVV 502G AA 12V 50mA
SW302	SWTA-00220-060	SWITCH-TACT	THVV 502G AA 12V 50mA
SW303	SWTA-00220-060	SWITCH-TACT	THVV 502G AA 12V 50mA
SW304	SWTA-00220-060	SWITCH-TACT	THVV 502G AA 12V 50mA
SW305	SWTA-00220-060	SWITCH-TACT	THVV 502G AA 12V 50mA
SW306	SWTA-00220-060	SWITCH-TACT	THVV 502G AA 12V 50mA
SW307	SWTA-00220-060	SWITCH-TACT	THVV 502G AA 12V 50mA
SW308	SWTA-00220-060	SWITCH-TACT	THVV 502G AA 12V 50mA
SW309	SWTA-00220-060	SWITCH-TACT	THVV 502G AA 12V 50mA
SW310	SWTA-00220-060	SWITCH-TACT	THVV 502G AA 12V 50mA
SW311	SWTA-00220-060	SWITCH-TACT	THVV 502G AA 12V 50mA
SW312	SWTA-00220-060	SWITCH-TACT	THVV 502G AA 12V 50mA
SW313	SWTA-00220-060	SWITCH-TACT	THVV 502G AA 12V 50mA
SW314	SWTA-00220-060	SWITCH-TACT	THVV 502G AA 12V 50mA
SW315	SWTA-00220-060	SWITCH-TACT	THVV 502G AA 12V 50mA
SW316	SWTA-00220-060	SWITCH-TACT	THVV 502G AA 12V 50mA
SW317	SWTA-00220-060	SWITCH-TACT	THVV 502G AA 12V 50mA
SW318	SWTA-00220-060	SWITCH-TACT	THVV 502G AA 12V 50mA
SW802	SWTA-00220-060	SWITCH-TACT	THVV 502G AA 12V 50mA
Q423	TRSA-01450-SJO	TRANSISTOR N-H FREQ	2SA1859A
Q424	TRSA-01450-SJO	TRANSISTOR N-H FREQ	2SA1859A
Q421	TRSC-01540-SJO	TRANSISTOR N-H FREQ	2SC4883A
Q422	TRSC-01540-SJO	TRANSISTOR N-H FREQ	2SC4883A
Q401	TRTA-0011G-SD0	TRANSISTOR P-H FREQ	KTA1268-GR TO92

Q425	TRSC-01780-SD0	TRANSISTOR NPN	2SC5200
Q426	TRSC-01780-SD0	TRANSISTOR NPN	2SC5200
Q427	TRSA-01770-SD0	TRANSISTOR PNP	2SA1943
Q428	TRSA-01770-SD0	TRANSISTOR PNP	2SA1943

Ref. No.	Part No.	Description		
<b>BLOCK FRONT PCB</b>				
Q402	TRTA-0011G-SD0	TRANSISTOR P-H FREQ	KTA1268-GR	TO92
Q403	TRTA-0011G-SD0	TRANSISTOR P-H FREQ	KTA1268-GR	TO92
Q404	TRTA-0011G-SD0	TRANSISTOR P-H FREQ	KTA1268-GR	TO92
Q405	TRTA-0011G-SD0	TRANSISTOR P-H FREQ	KTA1268-GR	TO92
Q406	TRTA-0011G-SD0	TRANSISTOR P-H FREQ	KTA1268-GR	TO92
Q407	TRTA-0011G-SD0	TRANSISTOR P-H FREQ	KTA1268-GR	TO92
Q408	TRTA-0011G-SD0	TRANSISTOR P-H FREQ	KTA1268-GR	TO92
Q413	TRTA-0011G-SD0	TRANSISTOR P-H FREQ	KTA1268-GR	TO92
Q414	TRTA-0011G-SD0	TRANSISTOR P-H FREQ	KTA1268-GR	TO92
Q431	TRTA-0011G-SD0	TRANSISTOR P-H FREQ	KTA1268-GR	TO92
Q415	TRTA-0013Y-SD0	TRANSISTOR N-H FREQ	KTA1024-Y	
Q416	TRTA-0013Y-SD0	TRANSISTOR N-H FREQ	KTA1024-Y	
Q409	TRTC-0015G-SD0	TRANSISTOR N-H FREQ	KTC3200-GR	TO92
Q410	TRTC-0015G-SD0	TRANSISTOR N-H FREQ	KTC3200-GR	TO92
Q411	TRTC-0015G-SD0	TRANSISTOR N-H FREQ	KTC3200-GR	TO92
Q412	TRTC-0015G-SD0	TRANSISTOR N-H FREQ	KTC3200-GR	TO92
Q429	TRTC-0015G-SD0	TRANSISTOR N-H FREQ	KTC3200-GR	TO92
Q430	TRTC-0015G-SD0	TRANSISTOR N-H FREQ	KTC3200-GR	TO92
Q301	TRTC-0016G-SD0	TRANSISTOR N-H FREQ	KTC3198-GR	TO92
Q432	TRTC-0016G-SD0	TRANSISTOR N-H FREQ	KTC3198-GR	TO92
Q433	TRTC-0016G-SD0	TRANSISTOR N-H FREQ	KTC3198-GR	TO92
Q434	TRTC-0016G-SD0	TRANSISTOR N-H FREQ	KTC3198-GR	TO92
Q417	TRTC-0087Y-SD0	TRANSISTOR N-H FREQ	KTC3206-Y	TO92L
Q418	TRTC-0087Y-SD0	TRANSISTOR N-H FREQ	KTC3206-Y	TO92L
Q302	TRTC-01700-SD0	TRANSISTOR N-H FREQ	KRC107M	W/RESIST TO92M
Q303	TRTC-01700-SD0	TRANSISTOR N-H FREQ	KRC107M	W/RESIST TO92M
Q304	TRTC-01700-SD0	TRANSISTOR N-H FREQ	KRC107M	W/RESIST TO92M
Q305	TRTC-01700-SD0	TRANSISTOR N-H FREQ	KRC107M	W/RESIST TO92M
Q306	TRTC-01700-SD0	TRANSISTOR N-H FREQ	KRC107M	W/RESIST TO92M
Q435	TRTC-01700-SD0	TRANSISTOR N-H FREQ	KRC107M	W/RESIST TO92M
	UA10-9M412-200	WIRE-ASSY	1007#20	WHT-120 10P
	UM08-A1033-000	WIRE-ASSY	1533#28/1007#26-150	10P
	UM08-41035-000	WIRE-ASSY	1533#28-180	4P
	U1T1-0GN20-T10	WIRE-ASSY	HIGH WRAP#22	BLK 200
	U208-2K815-000	WIRE-ASSY	20080#28	RED-150 2P
	U245-91327-450	WIRE-ASSY	1007#18-270	2P
	U508-4M716-200	WIRE-ASSY	1007#26	YEL-160 5P
	U710-6M742-200	WIRE-ASSY	1007#26	BLU-420
VR503	VRAE-P049W-104	VR-ROTARY	RK11K1160106-100KW	
VR501	VRAE-P050C-104	VR-ROTARY	RK14K1260106-100KCx2	
VR502	VRAE-P050C-104	VR-ROTARY	RK14K1260106-100KCx2	
CF602	BTCE-00040-107	FILTER-CERAMIC	SFE10.7MS2-A-TF21	
CF603	BTCE-00040-107	FILTER-CERAMIC	SFE10.7MS2-A-TF21	
CF604	BTCE-00450-045	FILTER-CERAMIC	AHCFM2-450AL	
C707	CCAT-F103Z-AAF	CAPACITOR CERAMIC	0.01uF	Z 25V F T
C708	CCAT-F103Z-AAF	CAPACITOR CERAMIC	0.01uF	Z 25V F T
C709	CCAT-F103Z-AAF	CAPACITOR CERAMIC	0.01uF	Z 25V F T
C710	CCAT-F103Z-AAF	CAPACITOR CERAMIC	0.01uF	Z 25V F T
C706	CCAT-F223Z-AAF	CAPACITOR CERAMIC	0.022uF	Z 25V F T
C620	CCAT-J101K-AAB	CAPACITOR CERAMIC	100PF	K 50V B T
C621	CCAT-J101K-AAB	CAPACITOR CERAMIC	100PF	K 50V B T
C626	CCAT-J101K-AAB	CAPACITOR CERAMIC	100PF	K 50V B T
C627	CCAT-J101K-AAB	CAPACITOR CERAMIC	100PF	K 50V B T
C628	CCAT-J101K-AAB	CAPACITOR CERAMIC	100PF	K 50V B T
C629	CCAT-J101K-AAB	CAPACITOR CERAMIC	100PF	K 50V B T

Ref. No.	Part No.	Description					
<b>BLOCK TUNER PCB</b>							
C640	CCAT-J104Z-AAF	CAPACITOR CERAMIC	0.1uF	Z 50V	F T		
C641	CCAT-J104Z-AAF	CAPACITOR CERAMIC	0.1uF	Z 50V	F T		
C642	CCAT-J104Z-AAF	CAPACITOR CERAMIC	0.1uF	Z 50V	F T		
C803	CCAT-J104Z-AAF	CAPACITOR CERAMIC	0.1uF	Z 50V	F T		
C669	CCAT-J473Z-AAF	CAPACITOR CERAMIC	0.047uF	Z 50V	F T		
C711	CCAT-J473Z-AAF	CAPACITOR CERAMIC	0.047uF	Z 50V	F T		
C703	CCAT-J560J-AAZ	CAPACITOR CERAMIC	56PF	J 50V	SL T		
C704	CCAT-J560J-AAZ	CAPACITOR CERAMIC	56PF	J 50V	SL T		
C652	CCAT-J561K-AAB	CAPACITOR CERAMIC	560PF	K 50V	B T		
C665	CCAT-J561K-AAB	CAPACITOR CERAMIC	560PF	K 50V	B T		
C666	CCAT-J680J-AAZ	CAPACITOR CERAMIC	68PF	J 50V	SL T		
C667	CCAT-J680J-AAZ	CAPACITOR CERAMIC	68PF	J 50V	SL T		
C613	CCCT-J103Z-0DF	CAPACITOR CERAMIC	0.01uF	Z 50V	F T		
C623	CCCT-J103Z-0DF	CAPACITOR CERAMIC	0.01uF	Z 50V	F T		
C801	CCCT-J222K-0DB	CAPACITOR CERAMIC	2200PF	K 50V	B T		
C802	CCCT-J222K-0DB	CAPACITOR CERAMIC	2200PF	K 50V	B T		
C602	CCCT-J223Z-OFF	CAPACITOR CERAMIC	0.022uF	Z 50V	F T		
C605	CCCT-J223Z-OFF	CAPACITOR CERAMIC	0.022uF	Z 50V	F T		
C606	CCCT-J223Z-OFF	CAPACITOR CERAMIC	0.022uF	Z 50V	F T		
C608	CCCT-J223Z-OFF	CAPACITOR CERAMIC	0.022uF	Z 50V	F T		
C609	CCCT-J223Z-OFF	CAPACITOR CERAMIC	0.022uF	Z 50V	F T		
C610	CCCT-J223Z-OFF	CAPACITOR CERAMIC	0.022uF	Z 50V	F T		
C611	CCCT-J223Z-OFF	CAPACITOR CERAMIC	0.022uF	Z 50V	F T		
C614	CCCT-J223Z-OFF	CAPACITOR CERAMIC	0.022uF	Z 50V	F T		
C615	CCCT-J223Z-OFF	CAPACITOR CERAMIC	0.022uF	Z 50V	F T		
C616	CCCT-J223Z-OFF	CAPACITOR CERAMIC	0.022uF	Z 50V	F T		
C636	CCCT-J223Z-OFF	CAPACITOR CERAMIC	0.022uF	Z 50V	F T		
C639	CCCT-J223Z-OFF	CAPACITOR CERAMIC	0.022uF	Z 50V	F T		
C661	CCCT-J223Z-OFF	CAPACITOR CERAMIC	0.022uF	Z 50V	F T		
C603	CCCT-J473Z-OJF	CAPACITOR CERAMIC	0.047uF	Z 50V	F T		
C619	CCCT-J473Z-OJF	CAPACITOR CERAMIC	0.047uF	Z 50V	F T		
C604	CCTT-J150J-0BC	CAPACITOR CERAMIC	15PF	J 50V	CH T		
C625	CCTT-J300J-0CC	CAPACITOR CERAMIC	30PF	J 50V	CH T		
C634	CCTT-J331J-0FZ	CAPACITOR CERAMIC	330PF	J 50V	SL T		
C624	CCTT-J390J-0DC	CAPACITOR CERAMIC	39PF	J 50V	CH T		
C651	CCTT-J681J-0BZ	CAPACITOR CERAMIC	680PF	J 50V	SL T		
C645	CEET-E101M-DIO	CAPACITOR E/ALUMINUM	100uF	M 16V 6.3x11	T		
C705	CEET-E101M-DIO	CAPACITOR E/ALUMINUM	100uF	M 16V 6.3x11	T		
C601	CEET-F470M-CIO	CAPACITOR E/ALUMINUM	47uF	M 25V 5x11	T		
C612	CEET-F470M-CIO	CAPACITOR E/ALUMINUM	47uF	M 25V 5x11	T		
C618	CEET-F470M-CIO	CAPACITOR E/ALUMINUM	47uF	M 25V 5x11	T		
C622	CEET-F470M-CIO	CAPACITOR E/ALUMINUM	47uF	M 25V 5x11	T		
C638	CEET-F470M-CIO	CAPACITOR E/ALUMINUM	47uF	M 25V 5x11	T		
C701	CEET-F470M-CIO	CAPACITOR E/ALUMINUM	47uF	M 25V 5x11	T		
C702	CEET-F470M-CIO	CAPACITOR E/ALUMINUM	47uF	M 25V 5x11	T		
C607	CEET-G100M-CIO	CAPACITOR E/ALUMINUM	10uF	M 35V 5x11	T		
C647	CEET-G100M-CIO	CAPACITOR E/ALUMINUM	10uF	M 35V 5x11	T		
C648	CEET-G100M-CIO	CAPACITOR E/ALUMINUM	10uF	M 35V 5x11	T		
C664	CEET-G100M-CIO	CAPACITOR E/ALUMINUM	10uF	M 35V 5x11	T		
C663	CEET-JR22M-CIO	CAPACITOR E/ALUMINUM	0.22uF	M 50V 5x11	T		
C630	CEET-JR47M-CIO	CAPACITOR E/ALUMINUM	0.47uF	M 50V 5x11	T		
C632	CEET-J1R0M-CIO	CAPACITOR E/ALUMINUM	1.0uF	M 50V 5x11	T		
C644	CEET-J1R0M-CIO	CAPACITOR E/ALUMINUM	1.0uF	M 50V 5x11	T		
C662	CEET-J1R0M-CIO	CAPACITOR E/ALUMINUM	1.0uF	M 50V 5x11	T		
C633	CEET-J3R3M-CIO	CAPACITOR E/ALUMINUM	3.3uF	M 50V 5x11	T		

Ref. No.	Part No.	Description				
<b>BLOCK TUNER PCB</b>						
C617	CEET-J4R7M-CIO	CAPACITOR E/ALUMINUM	4.7uF	M	50V 5x11	T
C631	CEET-J4R7M-CIO	CAPACITOR E/ALUMINUM	4.7uF	M	50V 5x11	T
C643	CEET-J4R7M-CIO	CAPACITOR E/ALUMINUM	4.7uF	M	50V 5x11	T
C650	CEET-J4R7M-CIO	CAPACITOR E/ALUMINUM	4.7uF	M	50V 5x11	T
C668	CEET-J4R7M-CIO	CAPACITOR E/ALUMINUM	4.7uF	M	50V 5x11	T
C670	CFMT-N223J-EK0	CAPACITOR F/POLYESTR	0.022uF	J	100V 7.4x13	T
C637	CFMT-N332J-DJ0	CAPACITOR F/POLYESTR	0.0033uF	J	100V 5.8x12	T
C646	CFMT-N393J-FK0	CAPACITOR F/POLYESTR	0.039uF	J	100V 8.5x13	T
C671	CFST-O471J-CJ0	CAPACITOR F/STYROL	470PF	J	125V 5.5x12	T
VD601	DDSV-00120-S10	DIODE-VVC	SVC321SPA-C2	AM8V	DO40S	
VD602	DDSV-00120-S10	DIODE-VVC	SVC321SPA-C2	AM8V	DO40S	
D601	DDTS-00070-S00	DIODE-SI	1SS133	(40V 0.11A)	DO-40 T	
D801	DDTS-00070-S00	DIODE-SI	1SS133	(40V 0.11A)	DO-40 T	
D802	DDTS-00070-S00	DIODE-SI	1SS133	(40V 0.11A)	DO-40 T	
ZD601	DDTZ-G051B-SOS	DIODE ZENER	MTZJ5.1B	4.94-5.20	DO34 T	
D701	DDTZ-G062B-SOS	DIODE ZENER	MTZJ6.2B	5.96-6.27	DO34 T	
IC701	ICDG-00560-S00	IC MOTOR DRIVER	BA6208	SIP9		
IC603	ICLN-03610-S10	IC PLL FM MPX	LA3401	DIP22		
IC604	ICLN-03620-S10	IC AM/FM IF	LA1266	DIP24		
IC602	ICLN-03680-S10	IC PLL	LC7218JM	SOP-24		
T606	IFFA-00110-E20	IFT-FM	AFA011	7mm-CAN		
T604	IFFD-00100-E20	IFT-FM DET	AFD010	7mm-CAN		
T605	KIAA-00260-E20	COIL-AM IFT	AAA-026	7MC-K502713N4-KR		
T603	KIAO-00460-E20	COIL-AM OSC	AAO046	MW 7mm - CAN		
T607	KIAT-00530-E20	COIL-AM ANT	AAT053	MW 7mm - CAN		
T601	KIML-A0010-E20	COIL-FM MPX FILTER	AMA001	19KHz 10mm-CAN		
T602	KIML-A0010-E20	COIL-FM MPX FILTER	AMA001	19KHz 10mm-CAN		
CN702	KNCW-00160-5S9	CONNECTOR-WAFER	53015-0510	2mm-WHT		
CN701	KNCW-00240-AT9	CONNECTOR-WAFER	53014-10	2.0mm WHT		
CW701	KNCW-00240-AT9	CONNECTOR-WAFER	53014-10	2.0mm WHT		
CN703	KNCW-00240-2T9	CONNECTOR-WAFER	53014-02	2.0mm WHT		
CW802	KNCW-00240-2T9	CONNECTOR-WAFER	53014-02	2.0mm WHT		
TP601	KNCW-01490-2T9	CONNECTOR-WAFER	JE115-AT-02P			
TP602	KNCW-01490-2T9	CONNECTOR-WAFER	JE115-AT-02P			
TP603	KNCW-01490-2T9	CONNECTOR-WAFER	JE115-AT-02P			
CH602	KNCW-01510-ES9	CONNECTOR-WAFER	35237-1410	2M/M 14P		
X601	KTAL-00041-072	CRYSTAL	HC-49/U	7.200000MHZ		
CF605	KTRE-00300-288	RESONATOR	ZTB456F11			
R655	PCSR-01440-31B	PCB-SINGLE	A3R-144	247x197x1.6t		
R613	RCFT-E101J-000	RESISTOR-CARBON FILM	100ohm	1/5W 5% T		
R629	RCFT-E101J-000	RESISTOR-CARBON FILM	100ohm	1/5W 5% T		
R634	RCFT-E101J-000	RESISTOR-CARBON FILM	100ohm	1/5W 5% T		
R639	RCFT-E101J-000	RESISTOR-CARBON FILM	100ohm	1/5W 5% T		
R648	RCFT-E101J-000	RESISTOR-CARBON FILM	100ohm	1/5W 5% T		
R651	RCFT-E101J-000	RESISTOR-CARBON FILM	100ohm	1/5W 5% T		
R673	RCFT-E101J-000	RESISTOR-CARBON FILM	100ohm	1/5W 5% T		
R603	RCFT-E102J-000	RESISTOR-CARBON FILM	1Kohm	1/5W 5% T		
R611	RCFT-E102J-000	RESISTOR-CARBON FILM	1Kohm	1/5W 5% T		
R618	RCFT-E102J-000	RESISTOR-CARBON FILM	1Kohm	1/5W 5% T		
R636	RCFT-E102J-000	RESISTOR-CARBON FILM	1Kohm	1/5W 5% T		
R637	RCFT-E102J-000	RESISTOR-CARBON FILM	1Kohm	1/5W 5% T		
R638	RCFT-E102J-000	RESISTOR-CARBON FILM	1Kohm	1/5W 5% T		
R654	RCFT-E102J-000	RESISTOR-CARBON FILM	1Kohm	1/5W 5% T		
R658	RCFT-E102J-000	RESISTOR-CARBON FILM	1Kohm	1/5W 5% T		
R703	RCFT-E102J-000	RESISTOR-CARBON FILM	1Kohm	1/5W 5% T		

Ref. No.	Part No.	Description	
<b>BLOCK TUNER PCB</b>			
R704	RCFT-E102J-000	RESISTOR-CARBON FILM	1Kohm 1/5W 5% T
R620	RCFT-E103J-000	RESISTOR-CARBON FILM	10Kohm 1/5W 5% T
R622	RCFT-E103J-000	RESISTOR-CARBON FILM	10Kohm 1/5W 5% T
R625	RCFT-E103J-000	RESISTOR-CARBON FILM	10Kohm 1/5W 5% T
R640	RCFT-E103J-000	RESISTOR-CARBON FILM	10Kohm 1/5W 5% T
R643	RCFT-E103J-000	RESISTOR-CARBON FILM	10Kohm 1/5W 5% T
R604	RCFT-E104J-000	RESISTOR-CARBON FILM	100Kohm 1/5W 5% T
R605	RCFT-E104J-000	RESISTOR-CARBON FILM	100Kohm 1/5W 5% T
R612	RCFT-E122J-000	RESISTOR-CARBON FILM	1.2Kohm 1/5W 5% T
R675	RCFT-E124J-000	RESISTOR-CARBON FILM	120Kohm 1/5W 5% T
R677	RCFT-E124J-000	RESISTOR-CARBON FILM	120Kohm 1/5W 5% T
R653	RCFT-E152J-000	RESISTOR-CARBON FILM	1.5Kohm 1/5W 5% T
R671	RCFT-E152J-000	RESISTOR-CARBON FILM	1.5Kohm 1/5W 5% T
R803	RCFT-E152J-000	RESISTOR-CARBON FILM	1.5Kohm 1/5W 5% T
R804	RCFT-E152J-000	RESISTOR-CARBON FILM	1.5Kohm 1/5W 5% T
R628	RCFT-E182J-000	RESISTOR-CARBON FILM	1.8Kohm 1/5W 5% T
R676	RCFT-E184J-000	RESISTOR-CARBON FILM	180Kohm 1/5W 5% T
R678	RCFT-E184J-000	RESISTOR-CARBON FILM	180Kohm 1/5W 5% T
R626	RCFT-E220J-000	RESISTOR-CARBON FILM	22ohm 1/5W 5% T
R630	RCFT-E220J-000	RESISTOR-CARBON FILM	22ohm 1/5W 5% T
R615	RCFT-E221J-000	RESISTOR-CARBON FILM	220ohm 1/5W 5% T
R616	RCFT-E221J-000	RESISTOR-CARBON FILM	220ohm 1/5W 5% T
R679	RCFT-E221J-000	RESISTOR-CARBON FILM	220ohm 1/5W 5% T
R614	RCFT-E222J-000	RESISTOR-CARBON FILM	2.2Kohm 1/5W 5% T
R642	RCFT-E223J-000	RESISTOR-CARBON FILM	22Kohm 1/5W 5% T
R650	RCFT-E223J-000	RESISTOR-CARBON FILM	22Kohm 1/5W 5% T
R619	RCFT-E271J-000	RESISTOR-CARBON FILM	270ohm 1/5W 5% T
R705	RCFT-E271J-000	RESISTOR-CARBON FILM	270ohm 1/5W 5% T
R627	RCFT-E273J-000	RESISTOR-CARBON FILM	27Kohm 1/5W 5% T
R607	RCFT-E331J-000	RESISTOR-CARBON FILM	330ohm 1/5W 5% T
R608	RCFT-E331J-000	RESISTOR-CARBON FILM	330ohm 1/5W 5% T
R609	RCFT-E332J-000	RESISTOR-CARBON FILM	3.3Kohm 1/5W 5% T
R635	RCFT-E332J-000	RESISTOR-CARBON FILM	3.3Kohm 1/5W 5% T
R652	RCFT-E332J-000	RESISTOR-CARBON FILM	3.3Kohm 1/5W 5% T
R672	RCFT-E332J-000	RESISTOR-CARBON FILM	3.3Kohm 1/5W 5% T
R674	RCFT-E332J-000	RESISTOR-CARBON FILM	3.3Kohm 1/5W 5% T
R606	RCFT-E4R7J-000	RESISTOR-CARBON FILM	4.7ohm 1/5W 5% T
R621	RCFT-E471J-000	RESISTOR-CARBON FILM	470ohm 1/5W 5% T
R623	RCFT-E472J-000	RESISTOR-CARBON FILM	4.7Kohm 1/5W 5% T
R631	RCFT-E472J-000	RESISTOR-CARBON FILM	4.7Kohm 1/5W 5% T
R632	RCFT-E472J-000	RESISTOR-CARBON FILM	4.7Kohm 1/5W 5% T
R633	RCFT-E472J-000	RESISTOR-CARBON FILM	4.7Kohm 1/5W 5% T
R646	RCFT-E472J-000	RESISTOR-CARBON FILM	4.7Kohm 1/5W 5% T
R624	RCFT-E473J-000	RESISTOR-CARBON FILM	47Kohm 1/5W 5% T
R647	RCFT-E473J-000	RESISTOR-CARBON FILM	47Kohm 1/5W 5% T
R649	RCFT-E473J-000	RESISTOR-CARBON FILM	47Kohm 1/5W 5% T
R610	RCFT-E561J-000	RESISTOR-CARBON FILM	560ohm 1/5W 5% T
R644	RCFT-E622J-000	RESISTOR-CARBON FILM	6.2Kohm 1/5W 5% T
R617	RCFT-E683J-000	RESISTOR-CARBON FILM	68Kohm 1/5W 5% T
R702	RCFT-E821J-000	RESISTOR-CARBON FILM	820ohm 1/5W 5% T
R645	RCFT-E823J-000	RESISTOR-CARBON FILM	82Kohm 1/5W 5% T
R655	RCFT-G471J-190	RESISTOR-CARBON FILM	470ohm 1/2W 5% 2.3x6.5 T
	RJWT-00000-AA0	RESISTOR-JUMPER WIRE	60mm-TX123 F
R701	RMOH-H820J-100	MOR	PRO1 1W 82ohm 5% R-SHAP
JK801	SKPH-00293-66W	SOCKET-PHONE	HTJ064-05BG GOLD

Ref. No.	Part No.	Description	
<b>BLOCK TUNER PCB</b>			
ANT601	TEAT-00143-02S	TERMINAL ANTENNA	SC021039FN
Q602	TRTA-00940-SD0	TRANSISTOR P-H FREQ	KRA107M W/RESIST TO92M
Q604	TRTA-00940-SD0	TRANSISTOR P-H FREQ	KRA107M W/RESIST TO92M
Q606	TRTA-00940-SD0	TRANSISTOR P-H FREQ	KRA107M W/RESIST TO92M
Q609	TRTA-00940-SD0	TRANSISTOR P-H FREQ	KRA107M W/RESIST TO92M
Q601	TRTC-0010Y-SD0	TRANSISTOR N-H FREQ	KTC3194-Y TO92
Q607	TRTC-0016G-SD0	TRANSISTOR N-H FREQ	KTC3198-GR TO92
Q608	TRTC-0016G-SD0	TRANSISTOR N-H FREQ	KTC3198-GR TO92
Q610	TRTC-0016G-SD0	TRANSISTOR N-H FREQ	KTC3198-GR TO92
Q701	TRTC-01060-SD0	TRANSISTOR N-H FREQ	KTC3203 TO92
Q702	TRTC-01700-SD0	TRANSISTOR N-H FREQ	KRC107M W/RESIST TO92M
Q603	TRTD-00200-SD0	TRANSISTOR N-L FREQ	KTD-1302 TO92
Q605	TRTD-00200-SD0	TRANSISTOR N-L FREQ	KTD-1302 TO92
FE601	TUFF-00232-00K	FM F/E TUNER	FTA3-509HA
	UM08-A1034-000	WIRE-ASS'Y	1533#28/1007#26-200 10P
	U310-2M530-200	WIRE-ASS'Y	1007#22 RED-300 3P
CT601	VCTC-00022-200	TRIMMER	CVCN06C200
VR602	VFEB-A021B-224	RESISTOR-SEMI FIXED	RH0638C-220KB 220Kohm
VR603	VFEB-A021B-472	RESISTOR-SEMI FIXED	RH0638C-4.7KB 4.7Kohm
VR601	VFEB-A021B-473	RESISTOR-SEMI FIXED	RH0638C-47KB 47Kohm
MV701	VWBD-E017A-503	VR-W/MOTOR	RK16812MG-50KAx2

### 3. Circuit Description

CPU(IC401) :uPD780204GF

#### 1. Pin Configuration

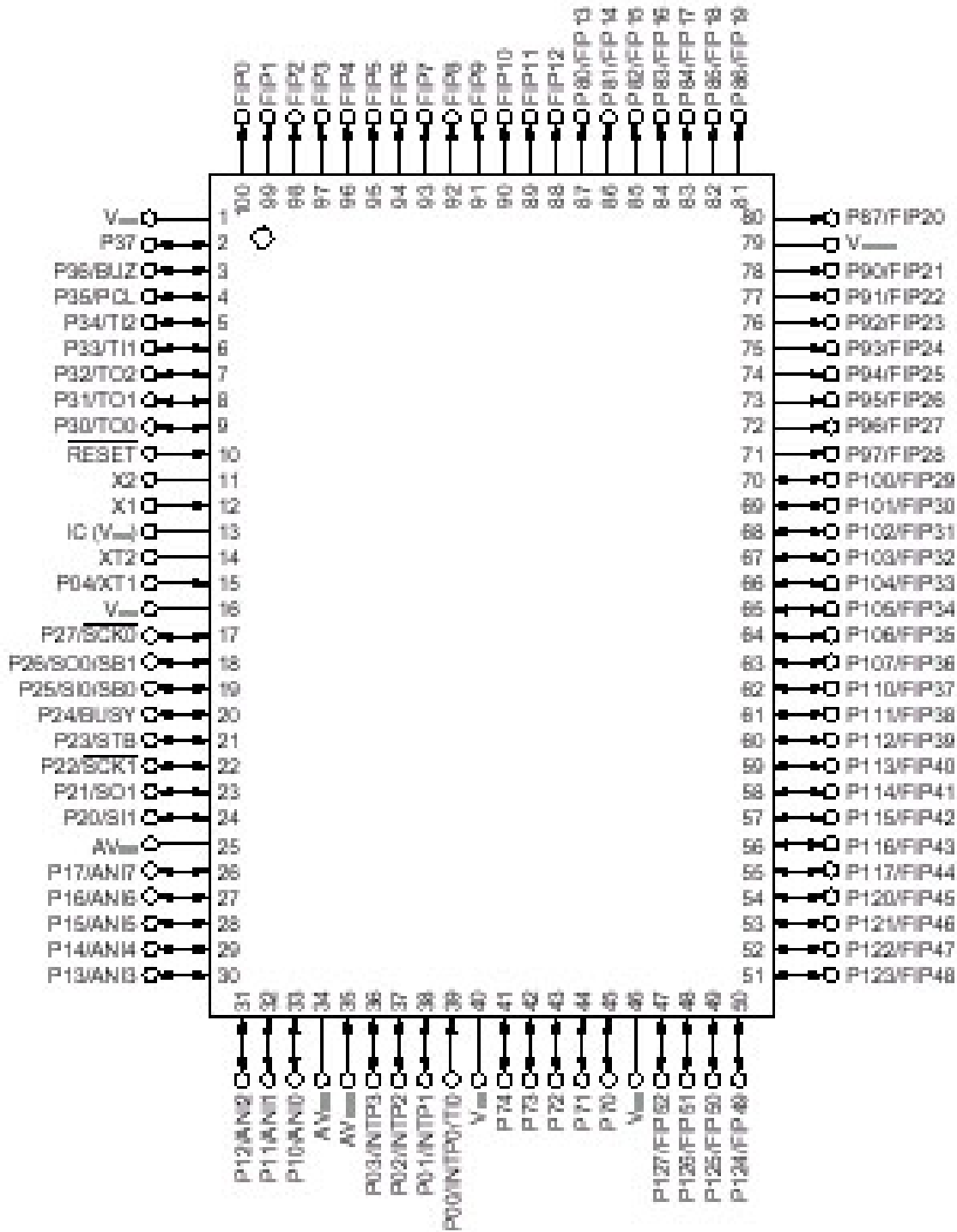

## 2. Pin Description

### uPD780204GF QFP Type

Pin No.	Pin Name	I/O	ACTIVE	PORT NAME	REMARK
1	Vdd	-	H	+5V	System power supply
2	P37	I	H	KR4	Key read 4
3	P36	I	H	KR3	Key read 3
4	P35	I	H	KR2	Key read 2
5	P34	I	H	KR1	Key read 1
6	P33	-	-	-	Not used
7	P32	-	-	-	Not used
8	P31	O	H/L	PWR_LED(RED)	L:AMBER L:GREEN H:RED
9	P30	O	H/L	PWR_LED(GRN)	L:STBY H:OPER L:PROT
10	RESET	I	L	System reset	Low reset
11	X2	-	-	OSC	Main system osc.
12	X1	I	-	OSC	-
13	Vpp	-	-	Connected to Vss	
14	XT2	-	-	-	Not used
15	P04/XT1	I	H/L	OPT_RDS	Rds on/off
16	Vdd	-	H	+5V	System power supply
17	P27	-	-		Not used
18	P26	-	-		Not used
19	P25	I	L	PWR_DOWN	Detect power off
20	P24	O	H	PWR_RLY	Power Relay on/off
21	P23	O	H	VR_UP	Volume up
22	P22	O	H	VR_DOWN	Volume Down
23	P21	I	L	PROTECT	Detect protection
24	P20	O	H	PWR_MUTE	Power Mute
25	AVss	-	L	GND	Analog ground
26	P17	O	H	PRE_MUTE	Pre mute
27	P16	O	H	TUNER_MUTE	Tuner mute
28	P15	I	H/L	IF_IN	IF conter in
29	P15	O	H	PLL CE	
30	P13	O	H	PLL CLOCK	
31	P12	O	H/L	PLL DATA	
32	P11	I	L	TUNED	Tuned in on : L
33	P10	I	L	STEREO	Stereo in on : L
34	Avdd	-	H	+5V	Analog power supply
35	Avref	-	L	GND	
36	P03	-	-		Not used
37	INTP2	I	L	RDS CLK	Rds clock in
38	P01	I	H	RDS DATA	Rds data in
39	P00	I	L	REMOCON IN	Remocon data in
40	Vss	-	L	GND	Ground
41	P74	O	H/L	78211 CLK	
42	P73	O	H/L	78211 CE	
43	P72	-	-		Not used
44	P71	-	-		Not used
45	P70	-	-		Not used
46	Vdd	-	H	+5V	



Pin No.	Pin Name	I/O	ACTIVE	PORT NAME	REMARK
47	P127	-	-		Not used
48	P127	-	-		Not used
49	P125	-	-		Not used
50	P124	O	H/L	78211 DATA	
51	P123	-	-		Not used
52	P122	-	-		Not used
53	P121	-	-		Not used
54	P120	-	-		Not used
55	P117	O	H	VMAX	VMAx on/off
56	P116	O	H	SPK1_RLY	Speaker1 relay on/off
57	P115	O	H	SPK2_RLY	Speaker2 relay on/off
58	P114	O	H	SPK1_LED	Speaker1 led on/off
59	P113	O	H	SPK2_LED	Speaker2 led on/off
60	P112	O	H	SPK12_LED	Speaker1/2 led on/off
61	P111	-	-		
62	P110	-	-		
63	P107	O	H	VR_LED	Volume led on/off
64	P106	I	H/L	OPT_STEP	L:E.U. , H:USA
65	P105	I	H/L	OPT_3400/3700	L:3400, H:3370
66	FIP33	O	H	S18	FIP segment output
67	FIP32	O	H	S17	FIP segment output
68	FIP31	O	H	S16	FIP segment output
69	FIP30	O	H	S15	FIP segment output
70	FIP29	O	H	S14	FIP segment output
71	FIP28	O	H	S13	FIP segment output
72	FIP27	O	H	S12	FIP segment output
73	FIP26	O	H	S11	FIP segment output
74	FIP25	O	H	S10	FIP segment output
75	FIP24	O	H	S9	FIP segment output
76	FIP23	O	H	S8	FIP segment output
77	FIP22	O	H	S7	FIP segment output
78	FIP21	O	H	S6	FIP segment output
79	Vload	-	-	Vload	FIP DRIVER VOLTAGE
80	FIP20	O	H	S5	FIP segment output
81	FIP19	O	H	S4	FIP segment output
82	FIP18	O	H	S3	FIP segment output
83	FIP17	O	H	S2	FIP segment output
84	FIP16	O	H	S1	FIP segment output
85	FIP15	O	H	G16	FIP grid output
86	FIP14	O	H	G15	FIP grid output
87	FIP13	O	H	G14	FIP grid output
88	FIP12	O	H	G13	FIP grid output
89	FIP11	O	H	G12	FIP grid output
90	FIP10	O	H	G11	FIP grid output
91	FIP9	O	H	G10	FIP grid output
92	FIP8	O	H	G9	FIP grid output
93	FIP7	O	H	G8	FIP grid output
94	FIP6	O	H	G7	FIP grid output
95	FIP5	O	H	G6	FIP grid output

Pin No.	Pin Name	I/O	ACTIVE	PORT NAME	REMARK
96	FIP4	O	H	G5	FIP grid output
97	FIP3	O	H	G4	FIP grid output
98	FIP3	O	H	G3	FIP grid output
99	FIP1	O	H	G2	FIP grid output
100	FIP0	O	H	G1	FIP grid output

**3. Timing Chart (IF Count)**

- ① PLL MODE 1
- ② PLL MODE 2
- ③ PLL MODE 3
- ④ PLL MODE 2
- ⑤ PLL MODE 3
- ⑥ PLL MODE 1

A dotted line (.....) : In case that IF COUNT is not proper, follow PLL MODE of ④ ⑤ ⑥

When changing BAND, selecting the PRESET STATION using TEN KEY and selecting the PRESET STATION using PRESET CHANNEL UP/DOWN

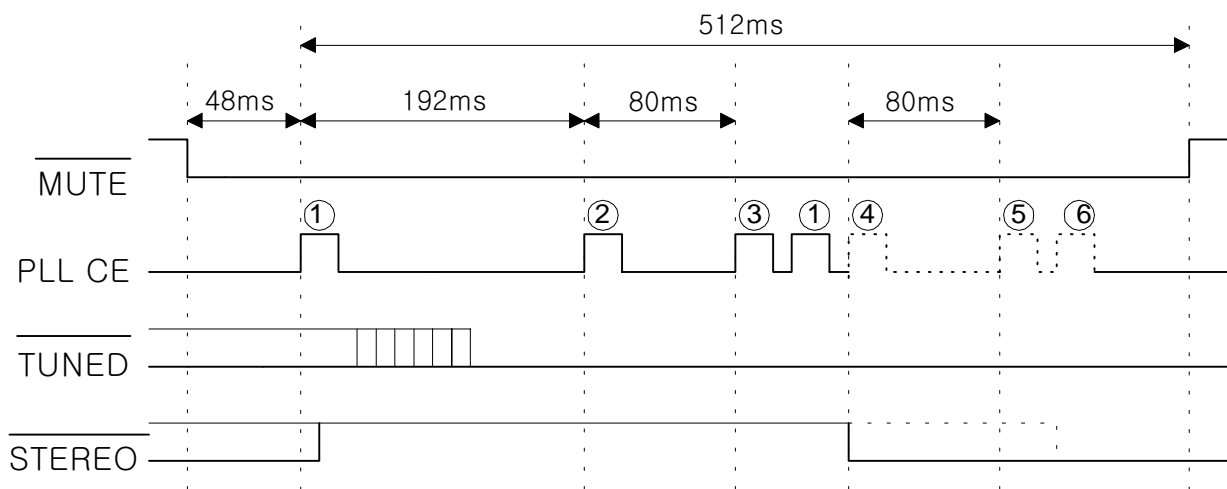

When IF COUNT is not proper in case that the frequency is not tuned

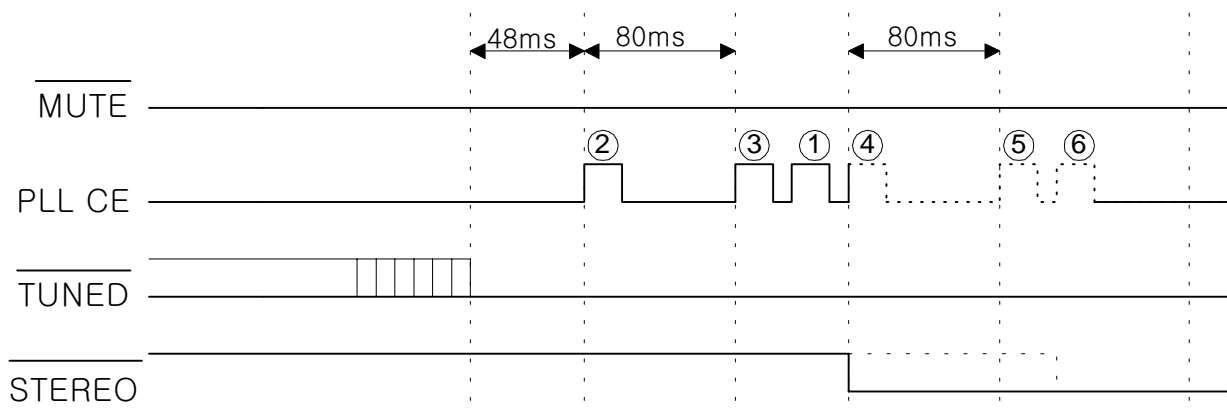

**MANUAL TUNING UP/DOWN**

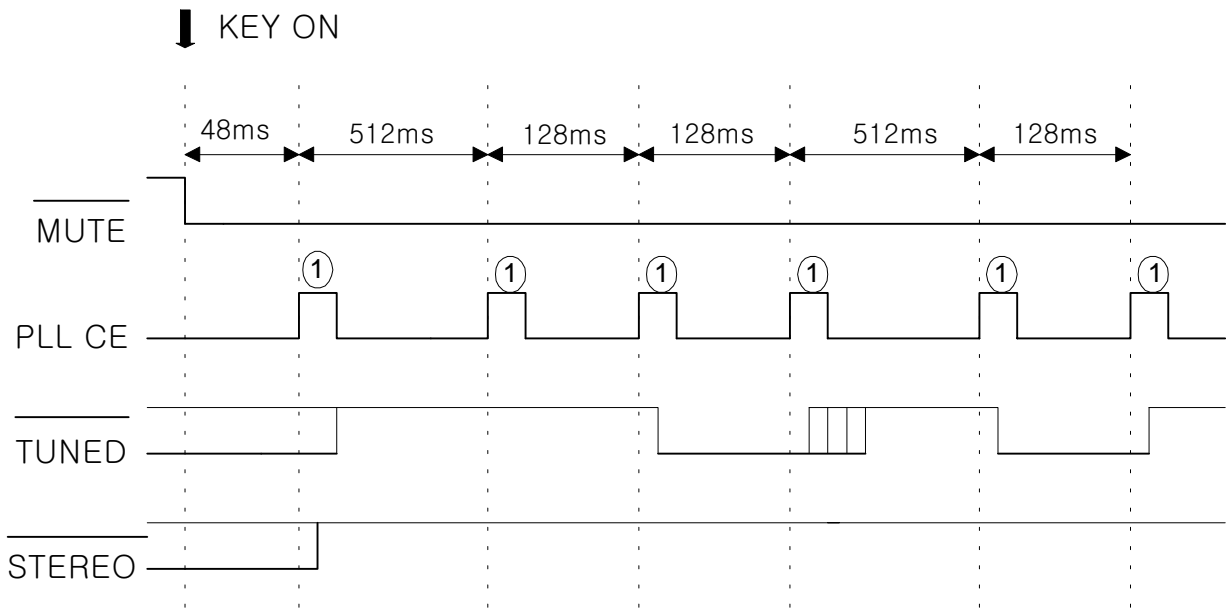

**MANUAL TUNING UP/DOWN KEY OFF**

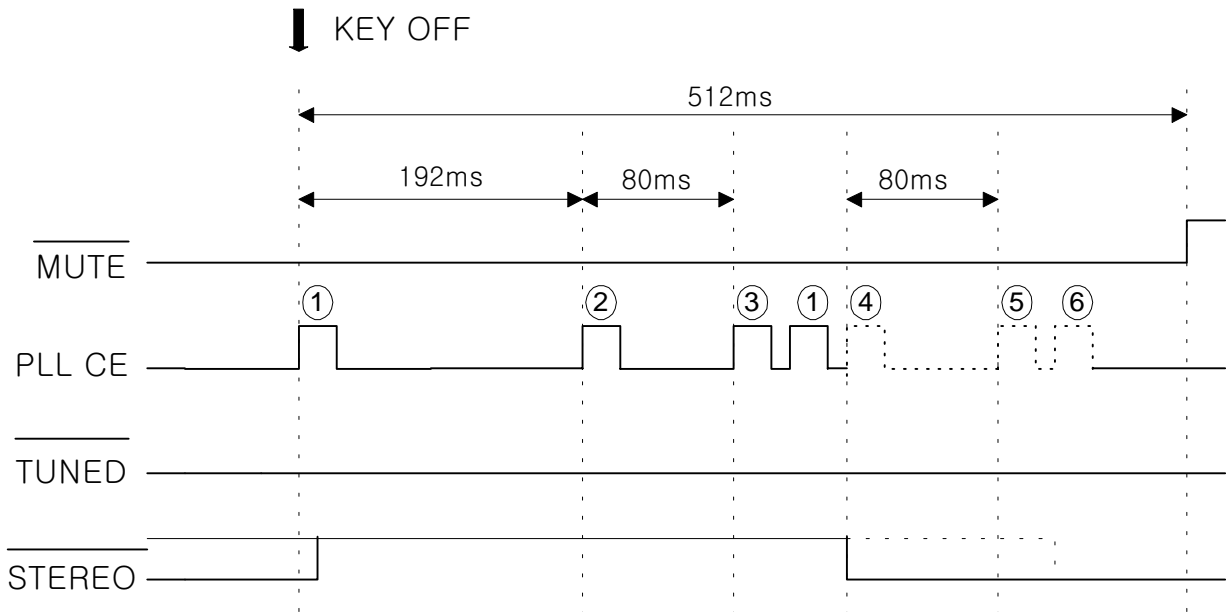

- POWER ON

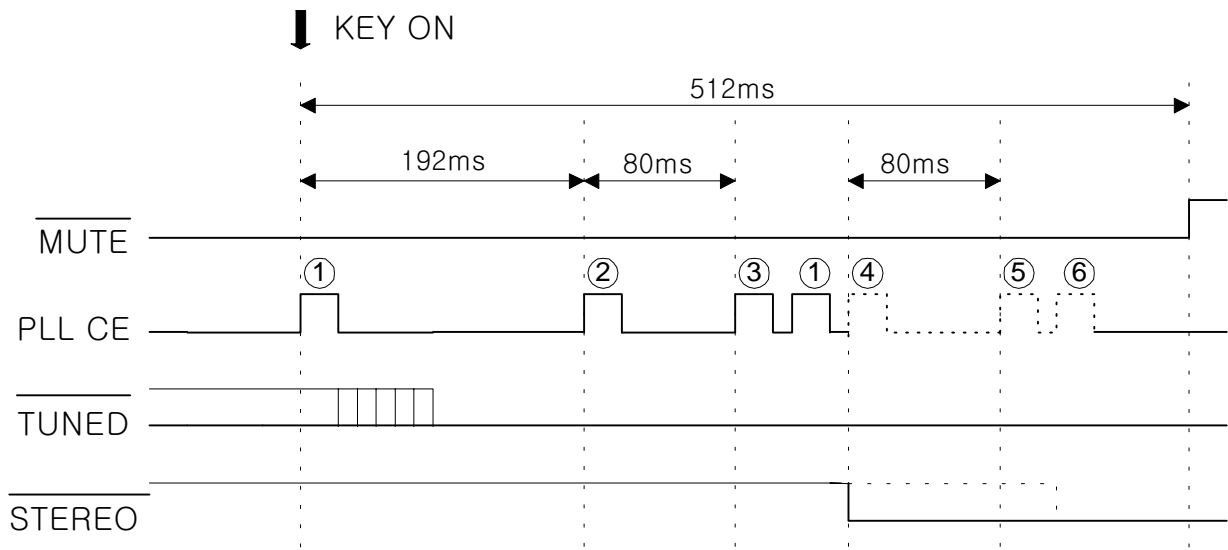

- AUTO TUNING UP/DOWN

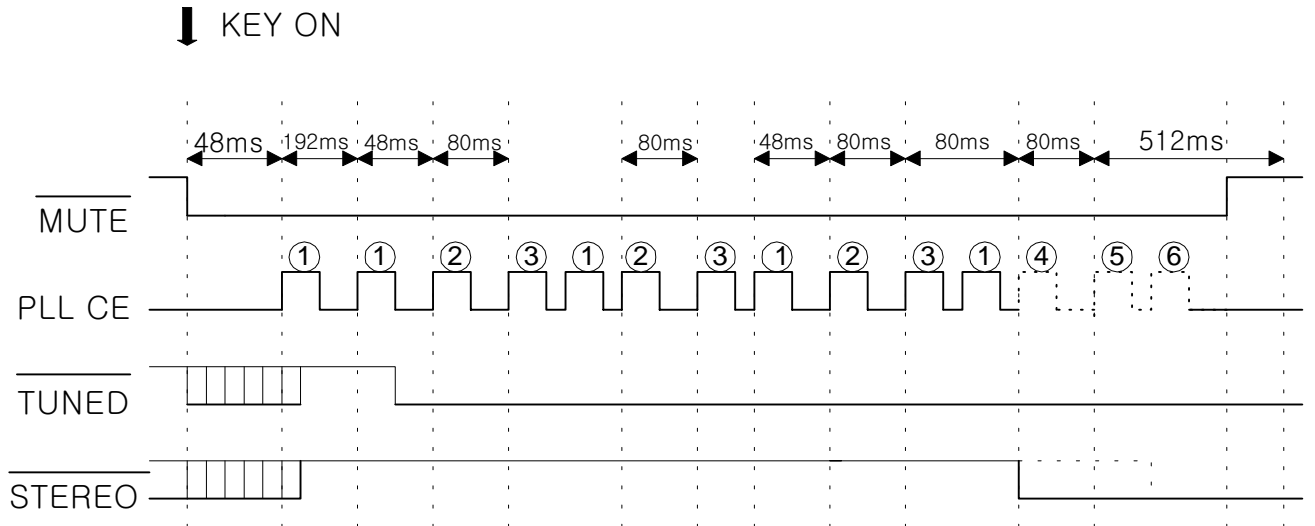

TUNED = HIGH  
IFCNT = NG

TUNED = LOW  
IFCNT = OK

### 4. Pheriperal IC Operation

1) FUNCTION IC. : LC7821-1/3

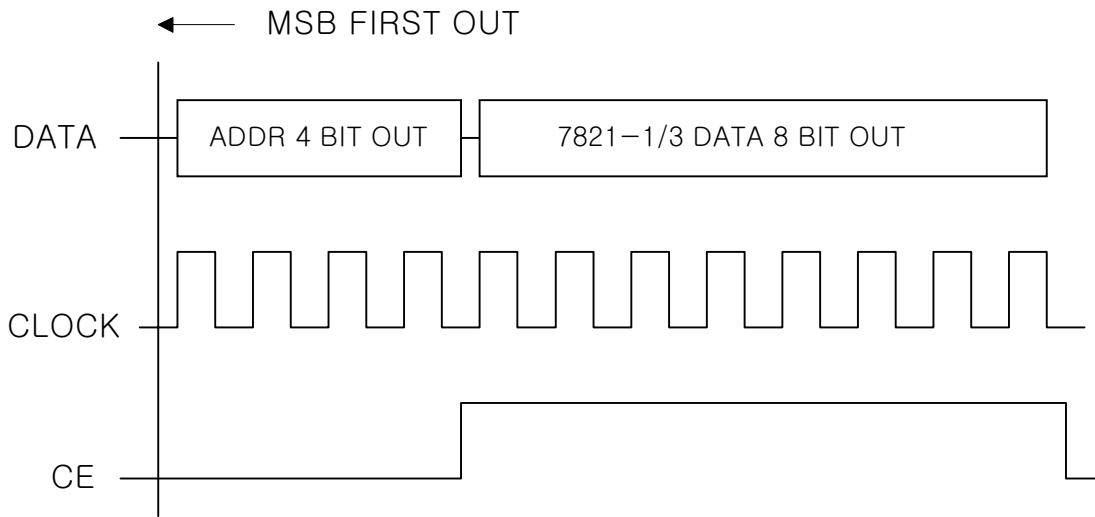

2) PLL IC. (LC7218)

1) MODE 1 : FREQUENCY OUT/ TUNED CHECK

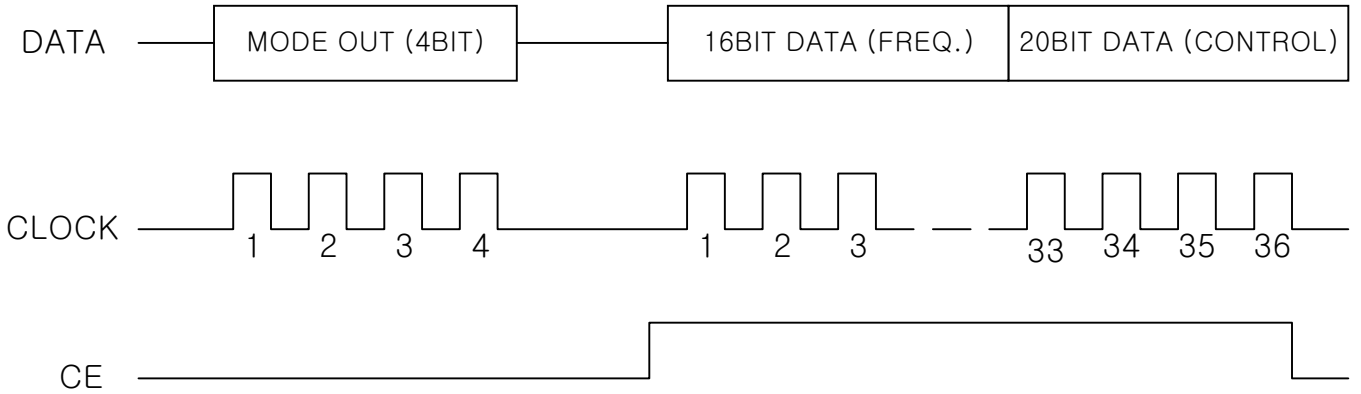

2) MODE 2 : FREQUENCY OUT/ OUTPUT CONTROL

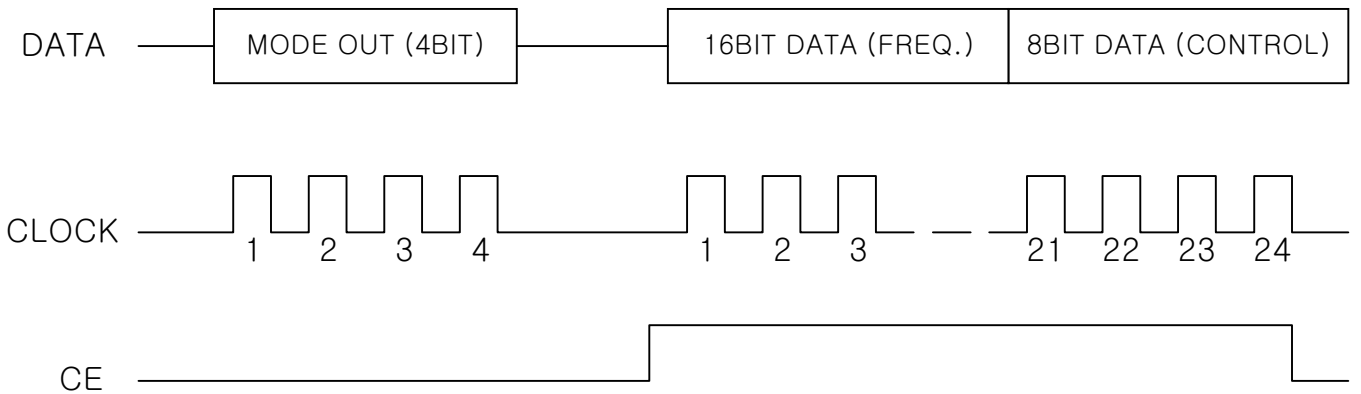

3) MODE 3 : IF COUNT READ

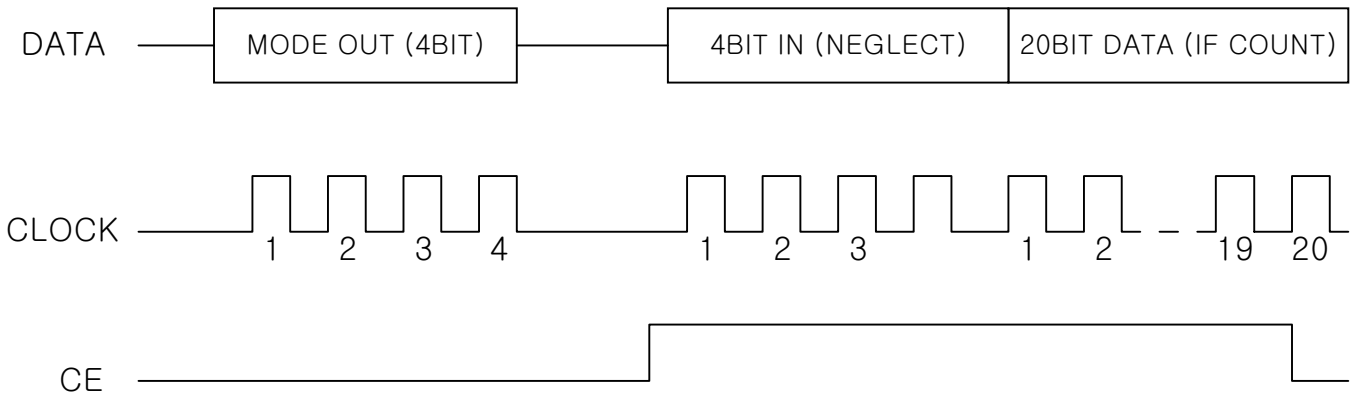

## Motor driver ICs

## Reversible motor driver

## BA6208 / BA6208F

The BA6208 and BA6208F are monolithic ICs used for driving reversible motors. They allow control of reversible motors in cassette players and other electrical equipment by using TTL-level logic signals.

The ICs contain a logic section, which controls forward and reverse rotations as well as forced stop, and an output power section, which can supply an output current of up to 100mA (typical) according to the logic control.

## ●Features

- 1) Motor driving power transistors are built in (100mA typically).
- 2) Brake is applied when stopping the motor (when inputs A and B are both HIGH level).
- 3) Built-in diode to absorb surge currents.
- 4) Very low standby circuit current when inputs A and B are both LOW level.
- 5) Wide range of operating supply voltage (4.5 ~ 15.0V).
- 6) Direct control with the TTL logic.

## ●Absolute maximum ratings (Ta = 25°C)

Parameter	Symbol	Limits	Unit
Power supply voltage	V <sub>CC</sub>	18	V
Power dissipation	BA6208	P <sub>d</sub>	700*1
	BA6208F	P <sub>d</sub>	450*2
Operating temperature	T <sub>opr</sub>	-20~+60	°C
Storage temperature	T <sub>stg</sub>	-55~+125	°C
Maximum output current	I <sub>OUT</sub>	500	mA

\*1 Reduced by 7 mW for each increase in Ta of 1°C over 25°C.

\*2 Reduced by 4.5 mW for each increase in Ta of 1°C over 25°C.

## ●Recommended operating conditions (Ta = 25°C)

Parameter	Symbol	Min.	Typ.	Max.	Unit
Power supply voltage	V <sub>CC</sub>	4.5	—	15	V

## ●Input truth table

3pin (Ain)	2pin (Bin)	8pin (Aout)	7pin (Bout)
H	L	H	L
L	H	L	H
H	H	L	L
L	L	OPEN	OPEN

Note : HIGH level input is 2.0 V or more.

LOW level input is 0.8 V or less.

Motor driver ICs

BA6208 / BA6208F

●Electrical characteristics (unless otherwise noted, Ta = 25°C and Vcc = 9V)

Parameter	Symbol	Min.	Typ.	Max.	Unit	Conditions
Output current	Io	200	—	—	mA	
Output saturation voltage	VCE	—	—	1.6	V	Io=100mA
Input high level voltage	VIH	2.0	—	—	V	
Input low level voltage	VIL	—	—	0.8	V	
Standby supply current	IST	—	—	0.4	mA	When inputs A and B are both LOW level
Input high level current	IiH	—	—	400	μA	VIH=4.5V

A diode that absorbs at least 500 mA is built in to give protection against surge currents with a pulse width of 10 ms and a duty ratio of 10% or less.

●Internal circuit configuration

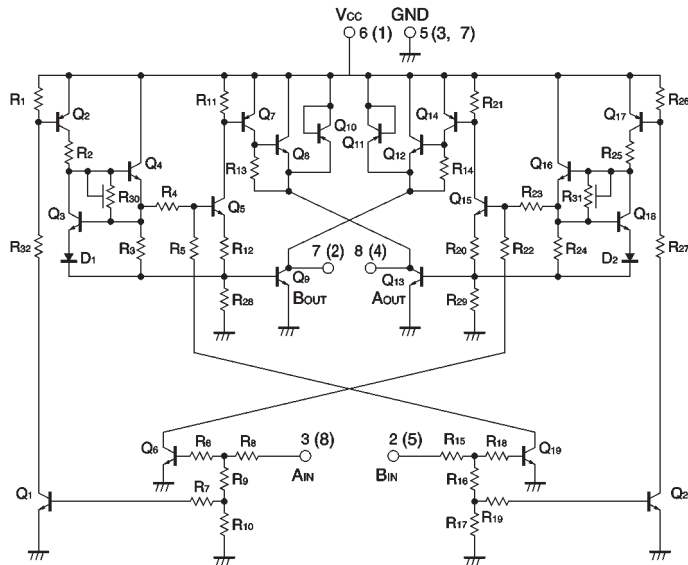

Note : Figures in parentheses are for the BA6208F

Fig.1

●External dimensions (Units: mm)

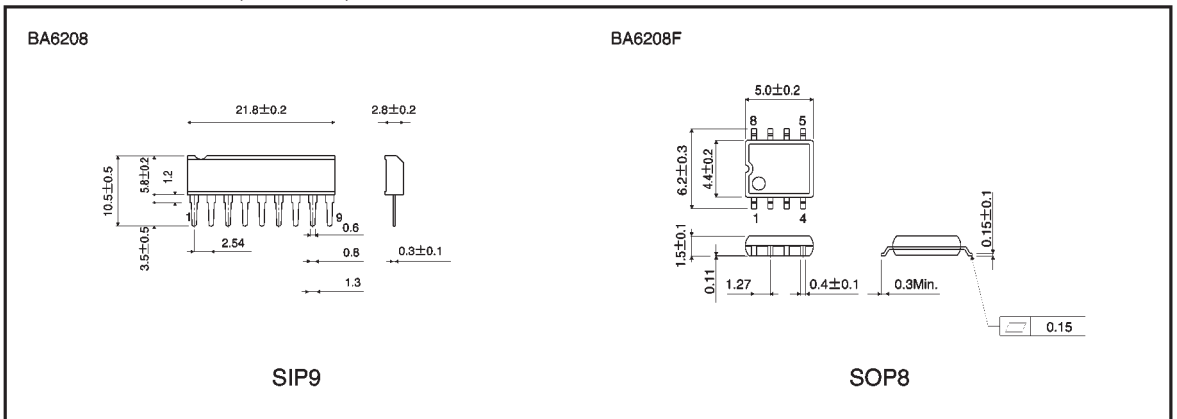



# KA4558

## Dual Operational Amplifier

### Features

- No frequency compensation required.
- No latch up.
- Large common mode and differential voltage range.
- Parameter tracking over temperature range.
- Gain and phase match between amplifiers.
- Internally frequency compensated.
- Low noise input transistors.

### Descriptions

The KA4558 is a monolithic integrated circuit designed for dual operational amplifier.

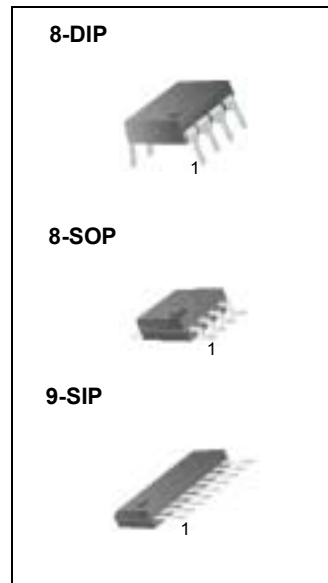

### Internal Block Diagram

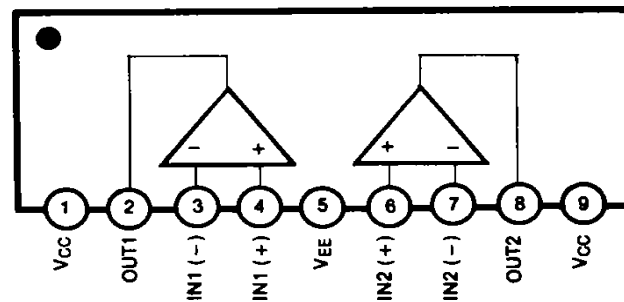
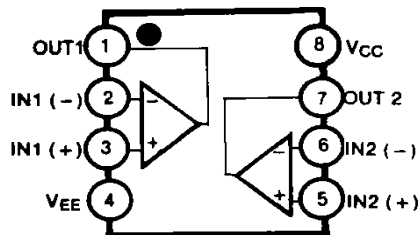

HI-M602H0 REMOTE RECEIVER

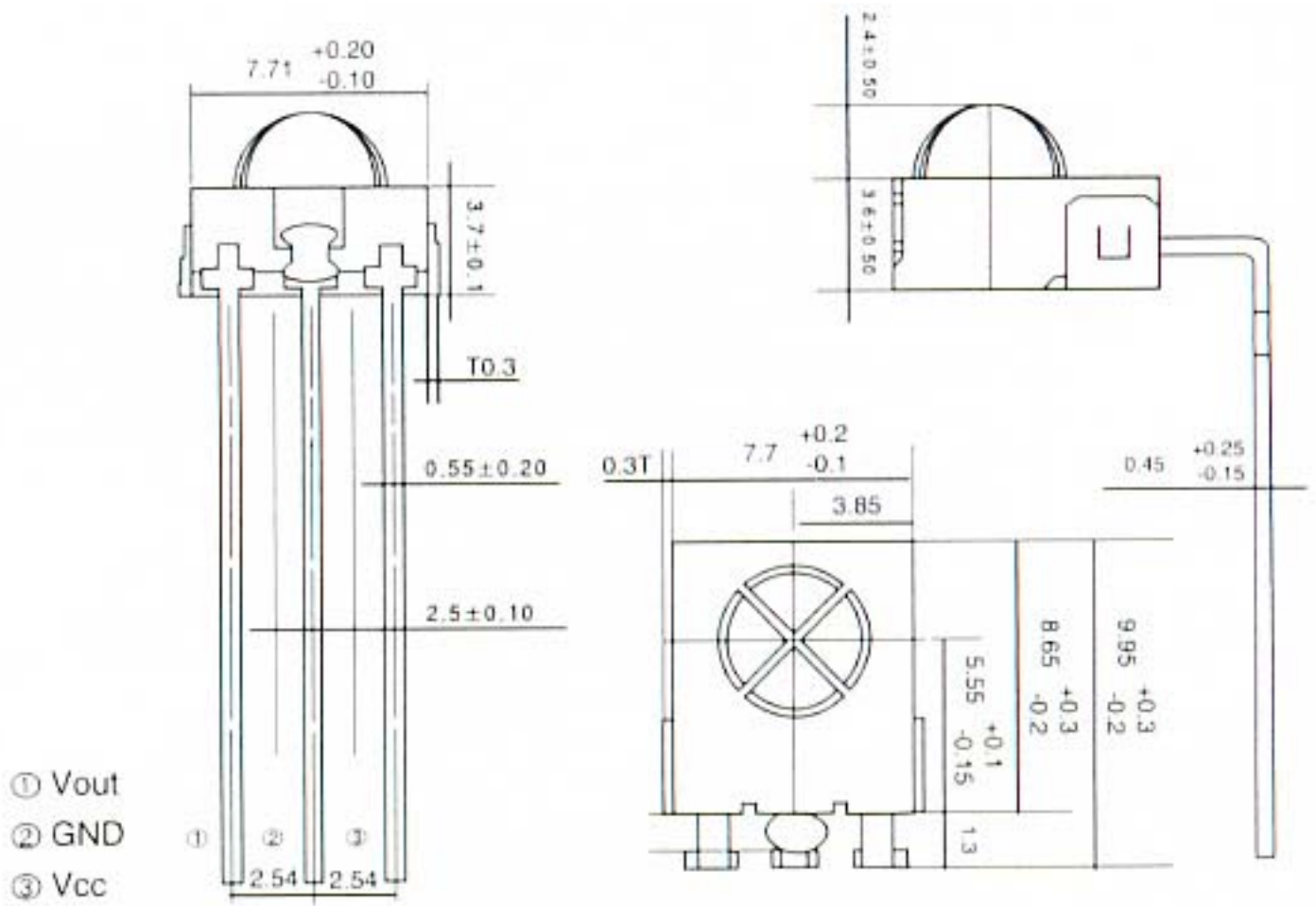

# KEC

# KIA7042

**BIPOLAR LINEAR INTEGRATED CIRCUIT**

**VOLTAGE DETECTOR**

Function of this IC is accurately resetting the system after detecting voltage at the time of switching power on and instantaneous power off in various CPU systems and other logic systems.

**FEATURES**

- Current Consumption is Low.  $I_{CCL}=300\mu$   $\mu$ A Typ.
- Resetting Output Minimum Guarantee Voltage is Low 0.8V Typ.
- Hysteresis Voltage is Provided. 50mV Typ.
- Reset Signal Generation Starting Voltages :
  - KIA7019 1.9V Typ. KIA7033 3.3V Typ.
  - KIA7021 2.1V Typ. KIA7034 3.4V Typ.
  - KIA7023 2.3V Typ. KIA7035 3.5V Typ.
  - KIA7025 2.5V Typ. KIA7036 3.6V Typ.
  - KIA7027 2.7V Typ. KIA7039 3.9V Typ.
  - KIA7029 2.9V Typ. KIA7042 4.2V Typ.
  - KIA7031 3.1V Typ. KIA7045 4.5V Typ.
  - KIA7032 3.2V Typ.
- Taping Type is also Available.

**APPLICATIONS**

- (1) As Control Circuit of Battery-Backed Memory.
- (2) As Measure Against Erroneous Operations at Power ON-OFF.
- (3) As Measure Against System Runaway at Instantaneous Break of Power Supply etc.
- (4) As Resetting Function for the CPU-Mounted Equipment, such as Personal Computers, Printers, VTRs and so forth.

**EQUIVALENT CIRCUIT**

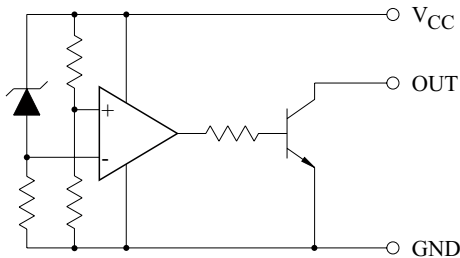

**Marking**

Type No.	Marking	Type No.	Marking	Type No.	Marking
KIA7019AF/AT	6A	KIA7029AF/AT	6F	KIA7035AF/AT	6L
KIA7021AF/AT	6B	KIA7031AF/AT	6G	KIA7036AF/AT	6M
KIA7023AF/AT	6C	KIA7032AF/AT	6H	KIA7039AF/AT	6N
KIA7025AF/AT	6D	KIA7033AF/AT	6J	KIA7042AF/AT	6P
KIA7027AF/AT	6E	KIA7034AF/AT	6K	KIA7045AF/AT	6R

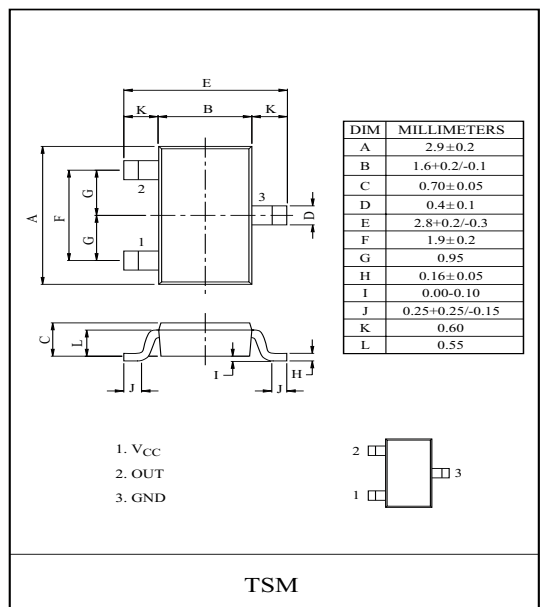
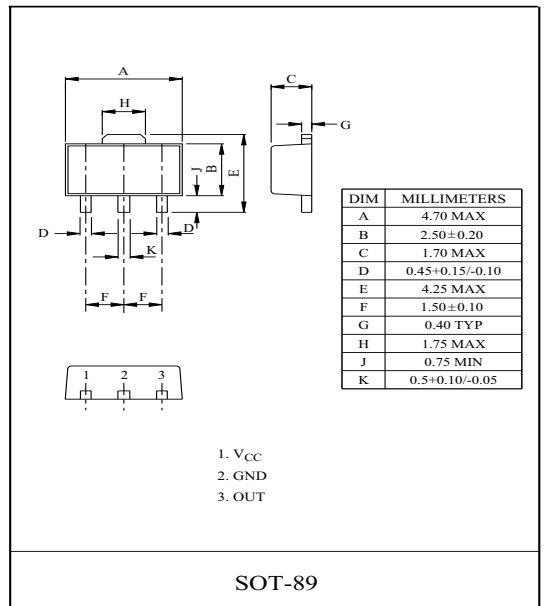
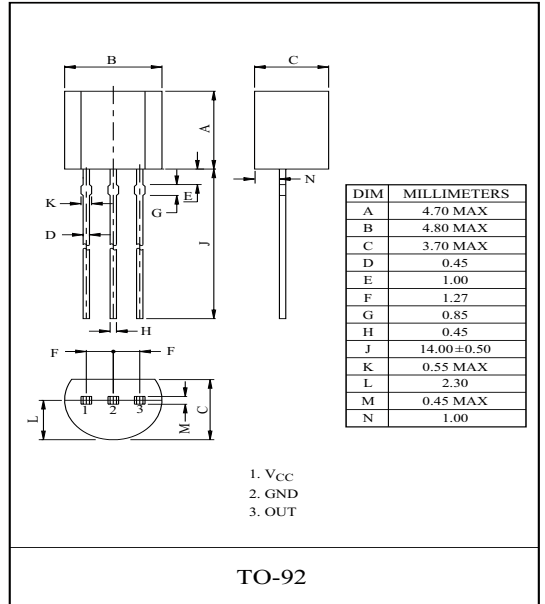

Ordering number: EN 1868C

Monolithic Linear IC

<b>SANYO</b>	No. 1868C	<b>LA3401</b>
	VCO NON-ADJUSTING PLL FM MPX STEREO DEMODULATOR WITH FM ACCESSORIES	

The LA3401 is a multifunctional MPX demodulator IC designed for FM stereo electronic tuning. It features the VCO non-adjusting function that eliminates the need to adjust free-running frequency of VCO and the accessory functions such as FM/AM input, FM/AM input changeover, muting.

### Applications

Home stereos, portable hi-fi sets

### Functions

- . VCO non-adjusting function
- . Gain variable type post amp
- . Muting at the FM-AM changeover mode (changeover mute)
- . Muting function
- . VCO stop function
- . Muting at the  $V_{CC}$ -ON mode
- . PLL MPX stereo demodulator
- . FM-AM changeover
- . Drive pin for external muting
- . Separation adjust function

### Features

- . Non-adjusting VCO: Eliminates the need to adjust free-running frequency.
- . Good temperature characteristic of VCO:  $\pm 0.1\%$  typ. for  $\pm 50^\circ\text{C}$  change.
- . Less high frequency distortion of stereo main signal (0.07% typ. at  $f=10\text{kHz}$ ) (Non-adjusting PLL makes it possible to make the capture range narrower, providing less high frequency beat distortion of stereo main signal.)
- . Low distortion: Mono 0.01% typ.  
Main 0.025% typ.
- . High S/N: 91dB typ./mono 300mV input, LPF  
94dB typ./mono 400mV input, LPF
- . High voltage gain: Approximately 13dB (Common to FM, AM at standard constants)  
This gain can be varied by external constants.
- . Wide dynamic range: Distortion 1.0%/mono 800mV, 1kHz input  
(Post amp gain: Approximately 13dB)
- . The semifixed resistor (pin 4) for separation adjust can be changed to a fixed resistor or can be removed.
- . High ripple rejection: 34dB typ.

### Package Dimensions 3059

(unit: mm)

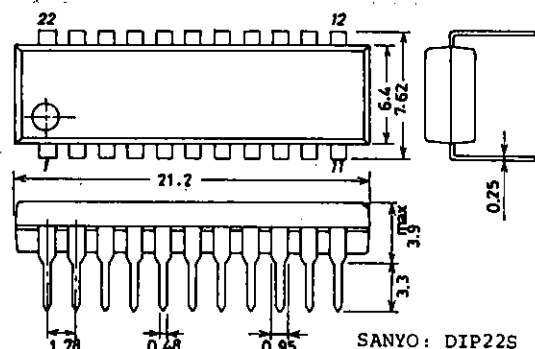

IC 603 : LA3401

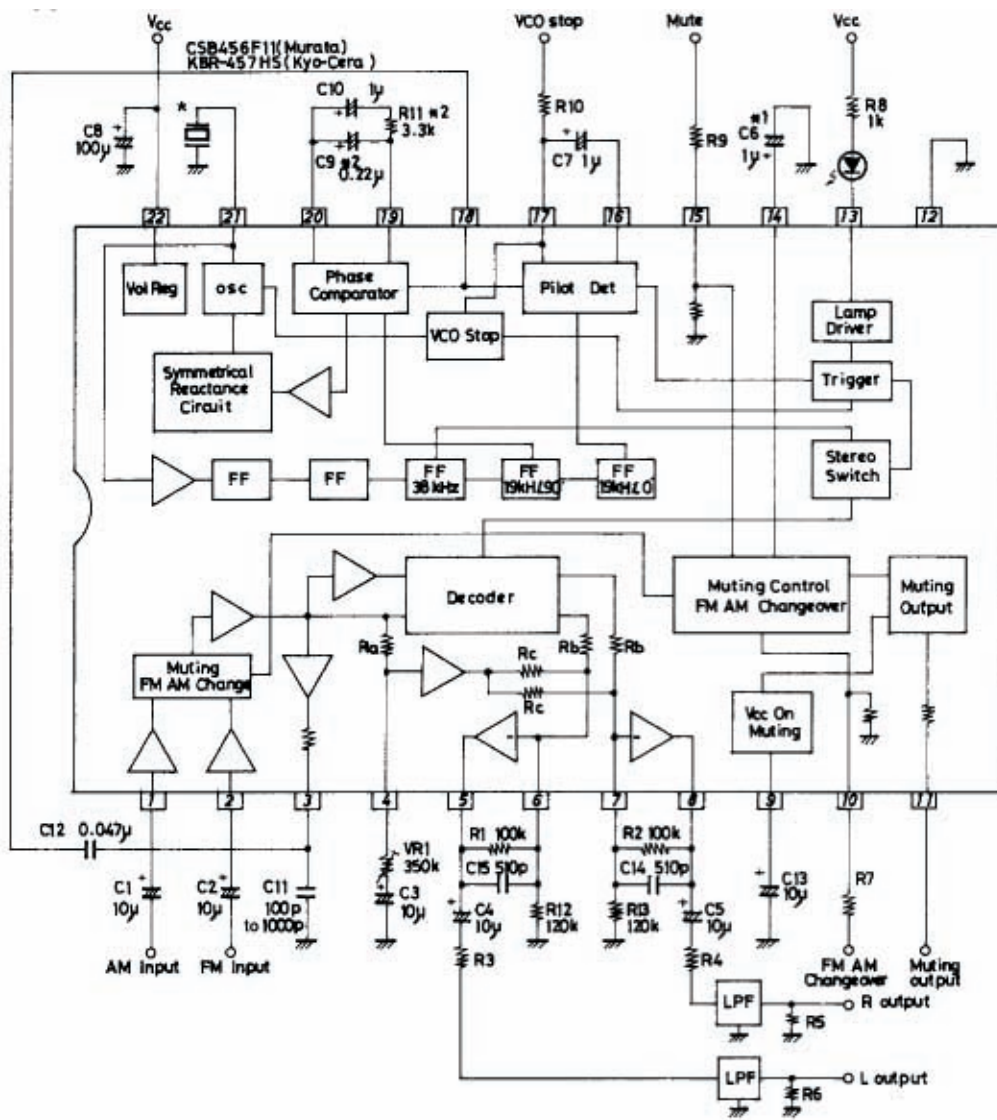

## LA3401

## External Parts

Part No.	Description	Remarks
C1	DC cut	
C2	"	Decreasing the value worsens separation at low frequencies.
C3	"	Decreasing the value worsens separation at low frequencies.
C4,5	"	
C6	Time constant for muting at changeover mode	Even when no FM/AM changeover muting is provided, a capacitor of 0.01 $\mu$ F or greater is connected.
C7	Sync detect filter	
C8	Power supply ripple filter	
C9	PLL loop filter	A capacitor value from 0.1 to 0.22 $\mu$ F is selected according to demodulation output of FM IF.(Note 1)
C10	PLL loop filter	Decreasing the value widens capture range; increasing the value delays stereo operation start timing after release of VCO stop.
C11	Improvement in low frequency stereo distortion	(L-R) signal and decoder 38kHz switching signal are phased with each other by a capacitor of 100 to 1000pF (differs with each audio set) connected.
C12	DC cut	
C13	Time constant for muting at $V_{CC}$ -ON mode	Output signal is muted for a certain time after application of power.
C14,15	De-emphasis constant	The values of C14, C15 are determined so that $R1 \cdot C15 = R2 \cdot C14 = 50\mu s (75\mu s)$ is yielded.
R1,2	Post amp feedback resistor	
R3,4	de-emphasis constant LPF input resistor	$R1 \cdot C15 = R2 \cdot C14 = 50\mu s (75\mu s)$ 3.3kohms or greater (If less than this, the maximum output voltage cannot be obtained.) Wiring between pin 5 and R3 and between pin 8 and R4 must be made as short as possible.
R5,6	LPF output resistor	
R7	Limiting resistor	The value of R7 is determined so that voltage applied to pin 10 becomes a value from 4.3V to $V_{CC} - 2V$ (not exceeding 10V).
R8	Limiting resistor	Current flowing into pin 13 must not exceed 30mA.
R9	Limiting resistor	The value of R9 is determined so that voltage applied to pin 15 becomes a value from 3.5V to $V_{CC} - 3V$ .
R10	Limiting resistor	The value of R10 is determined so that voltage applied to pin 17 becomes a value from 5V to $V_{CC} - 2V$ . For how to obtain R10, refer to VCO stop application mentioned later.

Continued on next page.

## LA3401

Continued from preceding page.

Part No.	Description	Remarks
R11	Loop filter	A resistor value from 3.3 to 10kohms is selected according to demodulation output of FM IF (Note 1). Increasing the value widens capture range, but delays stereo operation start timing after release of VCO stop (Note 2).
R12,13	Output DC voltage setting	Post amp output DC voltage $3.3(1+R_1/R12)$ or $3.3(1+R_2/R13)$ , extension in output dynamic range .
VR1	Separation adjust	Separation is adjusted by changing (L+R) signal level with VR1.
X	Free-running frequency setting	CSB456F11(Murata),KBR-457HS(Kyocera)

Note 1 : For C9, R11 setting, refer to Sample Application Circuit (Note 2) and Note 2 for Using IC.

Note 2 : To advance stereo operation start timing, the value of C10 is decreased. Decreasing the value of C10 narrows capture range. This narrowing also depends on the value of C9. It is recommended to use C10 of 0.47 $\mu$ F or greater.

## Pin Voltage, Name, Remarks

Pin No.	Voltage[V]	Pin Name	Remarks
1	3.3	AM input	Input resistor 20kohms
2	3.3	FM input	Input resistor 20kohms
3	3.3	Composite amp output	Output resistor 1kohm
4	3.3	Separation adjust	
5	3.3	Post amp output	L output
6	3.3	Post amp input	Minus input
7	3.3	Post amp input	Minus input
8	3.3	Post amp output	R output
9	3.3	V <sub>CC</sub> -ON muting	
10	-	FM/AM changeover	Input resistor 80kohms
11	-	Muting output	
12	0	GND	
13	-	Stereo indicator	Open collector
14	0 or 4.9	Changeover mute	Gnd through a capacitor of 0.01 $\mu$ F or greater
15	-	Muting	Input resistor 80kohms
16	2.7	Pilot sync detect filter	
17	2.7	Pilot sync detect filter, VCO stop	
18	2.7	PLL input	
19	2.7	Loop filter	
20	2.7	Loop filter	
21	-	OSC	 -4.2V
22	Vcc	Power supply	-2.5V

## Note for Using IC

## 1. Ceramic resonator

(1) Shown below are ceramic resonators recommended for use in the LA3401.

Type No.	Supplier
CSB456F11	Murata
KBR-457HS	Kyocera

# NJM2068

## LOW-NOISE DUAL OPERATIONAL AMPLIFIER

### ■ GENERAL DESCRIPTION

The NJM2068 is a high performance, low noise dual operational amplifier. This amplifier features popular pin-out, superior noise performance, and superior total harmonic distortion. This amplifier also features guaranteed noise performance with substantially higher gain-bandwidth product and slew rate, which far exceeds that of the 4558 type amplifier. The specially designed low noise input transistors allow the NJM2068 to be used in very low noise signal processing applications such as audio preamplifiers and servo error amplifier.

### ■ PACKAGE OUTLINE

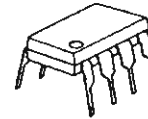

NJM2068D



NJM2068M



NJM2068V

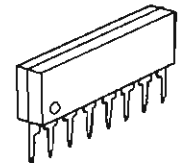

NJM2068L

### ■ FEATURES

- Operating Voltage (  $\pm 4V \sim \pm 18V$  )
- Low Total Harmonic Distortion ( 0.001% typ. )
- Low Noise Voltage ( FLAT+JISA,  $0.56\mu V$  typ. )
- High Slew Rate (  $6V/\mu s$  typ. )
- Unity Gain Bandwidth ( 27MHz @  $f=10kHz$  )
- Package Outline DIP8, DMP8, SIP8, SSOP8
- Bipolar Technology

### ■ PIN CONFIGURATION

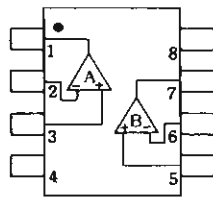

NJM2068D  
NJM2068M  
NJM2068V

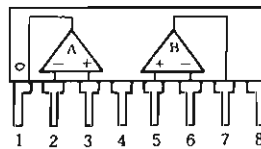

NJM2068L

- PIN FUNCTION**
- 1.A OUTPUT
  - 2.A -INPUT
  - 3.A +INPUT
  - 4.V<sup>-</sup>
  - 5.B +INPUT
  - 6.B -INPUT
  - 7.B OUTPUT
  - 8.V<sup>+</sup>

### ■ EQUIVALENT CIRCUIT ( 1/2 Shown )

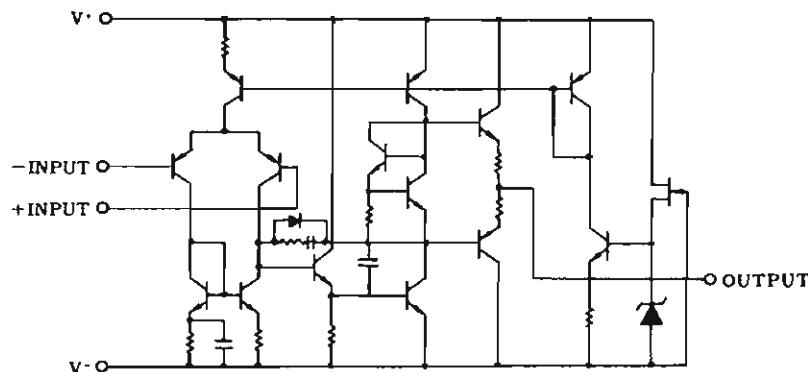



CMOS LSI



No.2294A

# LC7821, 7822, 7823

## Analog Function Switch

**Use**

- . Serial data-controlled function select switch suited for use in amplifiers, receivers.

**Features**

- . Analog switches of 8 channels x 2 (LC7823: 7 channels x 2) are contained. Three types are available according to the internal connection.
- . Control is exercised by serial data. The LC7821,7822,7823 may be interfaced with a microcomputer (5V-operated) easily.
- . Even if two ICs of the same type are used, they may be connected to the common bus line because the S (selector) pin is provided.
- . Reset pin used to turn OFF all analog switches
- . Wide dynamic range because of  $\pm 20V$  breakdown voltage

**Absolute Maximum Ratings at Ta=25°C**

				unit
Maximum Supply Voltage	$V_{DDmax}$	$V_{DD}$	-0.3 to +20	V
	$V_{EEmax}$	$V_{EE}$	-20 to +0.3	V
Maximum Input Voltage	$V_{I1}$	DI, CL, CE, S, $\overline{RES}$	-0.3 to +20	V
	$V_{I2}$	L1toL8, R1toR8, $V_{EE}-0.3toV_{DD}+0.3$ LCOM1 to LCOM4, RCOM1 to RCOM4		V
Analog Switch ON-State Voltage Difference	$\Delta V_{ON}$	Switch ON	0.5	V
Allowable Power Dissipation	$P_{dmax}$	$T_a \leq 75^\circ C$	100	mW
Operating Temperature	$T_{opr}$		-30 to +75	°C
Storage Temperature	$T_{stg}$		-40 to +125	°C

**Pin Assignment**

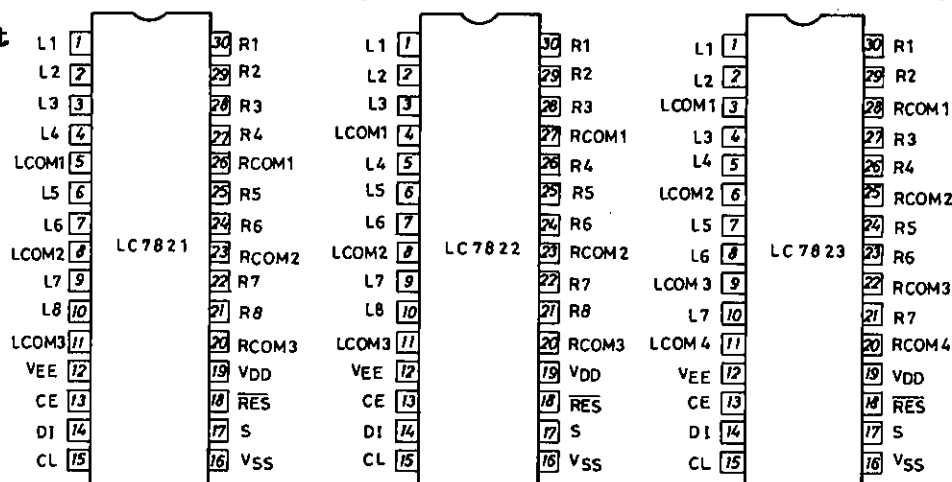

**Package Dimensions 3047A**  
(unit: mm)

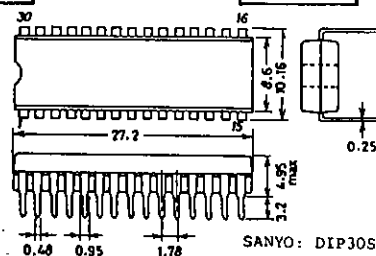

LC7821,7822,7823

Equivalent Circuit Block Diagram

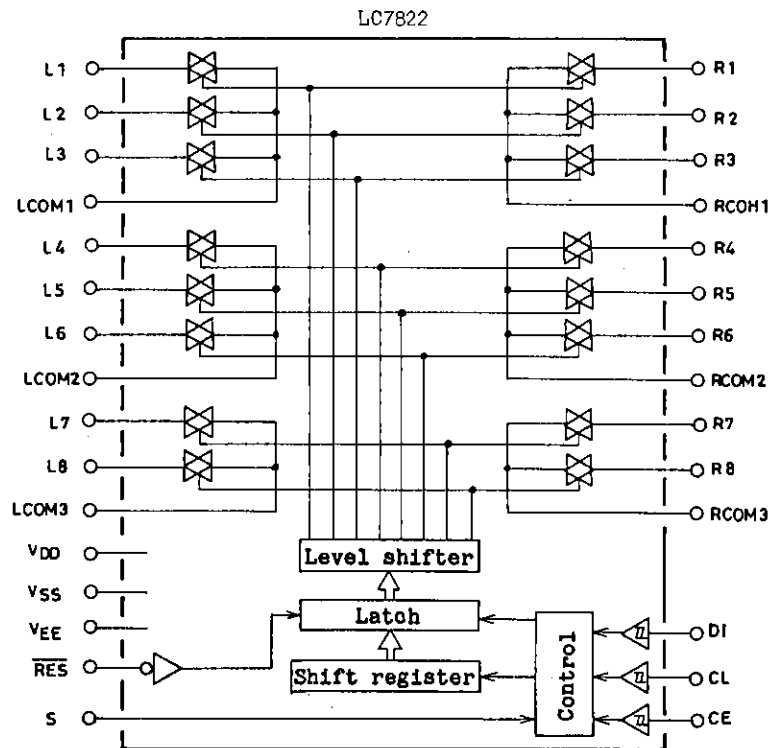
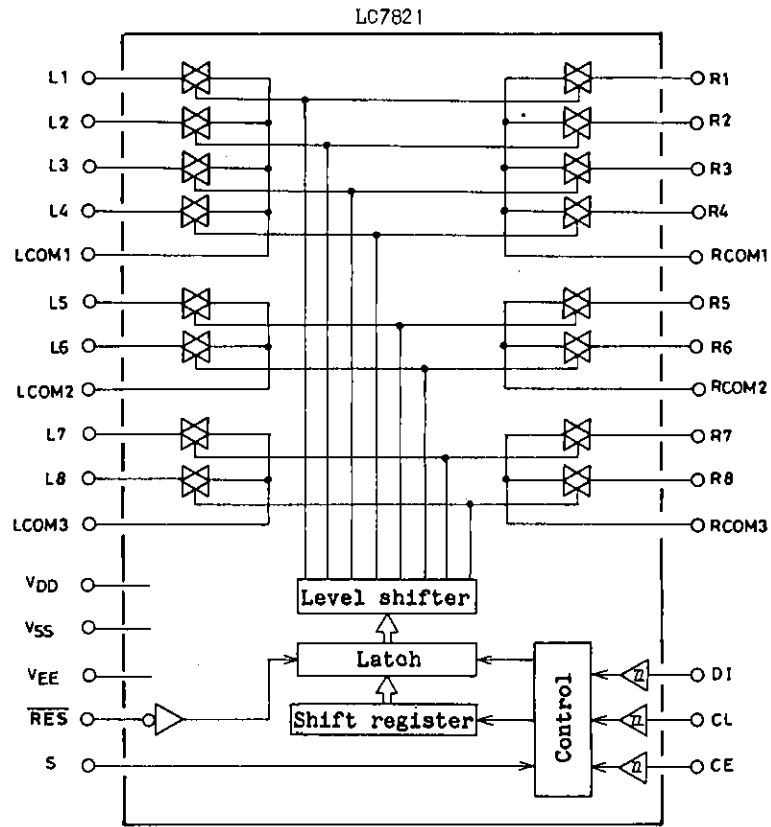

LC7821,7822,7823

Equivalent Circuit Block Diagram

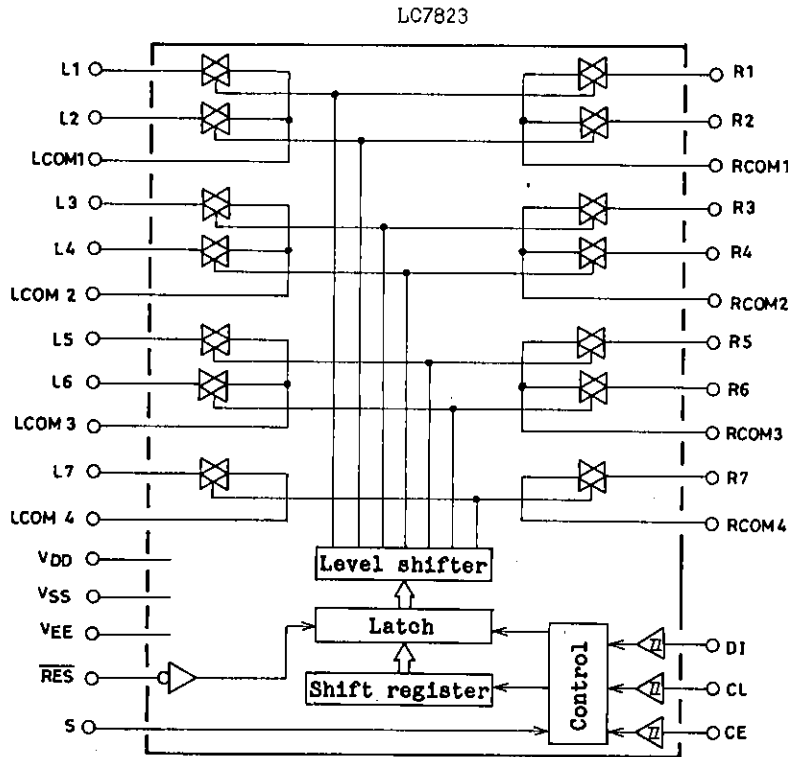

Pin Description

Pin Name	I/O	Internal Equivalent Circuit	Function																																											
VDD, VSS, VEE			Power supply pins																																											
L1 to L8, R1 to R8, LCOM1 to LCOM4, RCOM1 to RCOM4		See Block Diagram.	Input/output pins for analog switches.																																											
CL, DI, CE	I		Serial data input pins (Schmitt buffer) CL --- Clock input pin DI --- Data input pin CE --- Chip enable pin																																											
S	I		Select pin in the two ICs-used mode When the S pin is brought to "L" or "H" level, the addresses will become as shown below. <table border="1" style="margin-left: auto; margin-right: auto;"> <thead> <tr> <th rowspan="2">Type No.</th> <th rowspan="2">S Pin</th> <th colspan="4">Address</th> </tr> <tr> <th>A<sub>0</sub></th> <th>A<sub>1</sub></th> <th>A<sub>2</sub></th> <th>A<sub>3</sub></th> </tr> </thead> <tbody> <tr> <td rowspan="2">LC7821</td> <td>L</td> <td>0</td> <td>1</td> <td>0</td> <td>1</td> </tr> <tr> <td>H</td> <td>1</td> <td>1</td> <td>0</td> <td>1</td> </tr> <tr> <td rowspan="2">LC7822</td> <td>L</td> <td>0</td> <td>0</td> <td>1</td> <td>1</td> </tr> <tr> <td>H</td> <td>1</td> <td>0</td> <td>1</td> <td>1</td> </tr> <tr> <td rowspan="2">LC7823</td> <td>L</td> <td>0</td> <td>1</td> <td>1</td> <td>1</td> </tr> <tr> <td>H</td> <td>1</td> <td>1</td> <td>1</td> <td>1</td> </tr> </tbody> </table>	Type No.	S Pin	Address				A <sub>0</sub>	A <sub>1</sub>	A <sub>2</sub>	A <sub>3</sub>	LC7821	L	0	1	0	1	H	1	1	0	1	LC7822	L	0	0	1	1	H	1	0	1	1	LC7823	L	0	1	1	1	H	1	1	1	1
Type No.	S Pin	Address																																												
		A <sub>0</sub>	A <sub>1</sub>	A <sub>2</sub>	A <sub>3</sub>																																									
LC7821	L	0	1	0	1																																									
	H	1	1	0	1																																									
LC7822	L	0	0	1	1																																									
	H	1	0	1	1																																									
LC7823	L	0	1	1	1																																									
	H	1	1	1	1																																									
RES	I		Reset pin When power is applied, the state of the analog switches will be indeterminate. When this pin is brought to "L" level, all analog switches will be turned OFF.																																											



## LC7218, 7218M, 7218JM

### PLL Frequency Synthesizer for Electronic Tuning in AV Systems



#### Overview

The LC7218, LC7218M and LC7218JM are PLL frequency synthesizers for electronic tuning. The LC7218, LC7218M and LC7218JM are optimal for AM/FM tuner circuits that require high mounting densities.

#### Features

- These products feature a rich set of built-in functions for AV applications, including reference frequency and unlock detection circuits, I/O ports and a general-purpose counter.

#### Functions

- Programmable dividers
  - FMIN pin: 130 MHz at 70 mVrms and 160 MHz at 100 mVrms input (built-in prescaler)
  - AMIN pin: Pulse swallower and direct division techniques
- Reference frequencies: Ten selectable frequencies: 1, 5, 9, 10, 3.125, 6.25, 12.5, 25, 50 and 100 kHz
- Output ports: 7 pins  
Complementary outputs: 2 pins  
N-channel open drain outputs: 5 pins
- Input ports: 2 pins
- General-purpose counter: For measuring IF and other signals (Also used for station detection when functioning as an IF counter.)
  - HCTR pin: Frequency measurement (for inputs up to 70 MHz)
  - LCTR pin: Frequency and period measurement
- PLL unlock detection circuit  
Detects phase differences of 0.55, 1.11, 2.22 and 3.33  $\mu$ s.
- Controller clock output: 400 kHz
- Clock time base output: 8 Hz
- Serial data I/O
  - Supports CCB format communication with the system controller.
- Package: LC7218: DIP24S  
LC7218M: MFP24  
LC7218JM: MFP24S

#### Package Dimensions

unit: mm

3067-DIP24S

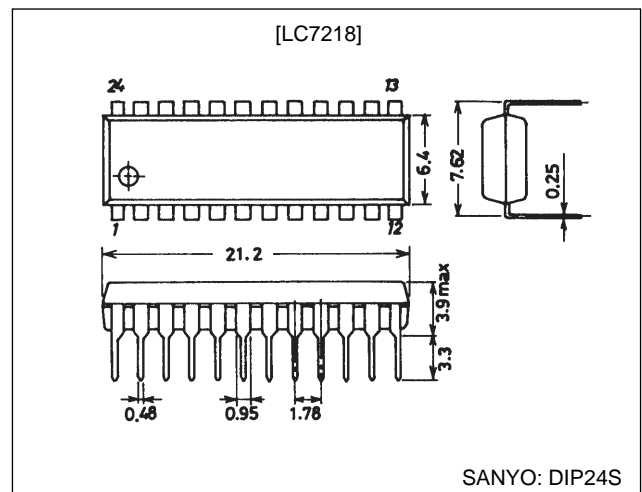

- CCB is a trademark of SANYO ELECTRIC CO., LTD.
- CCB is SANYO's original bus format and all the bus addresses are controlled by SANYO.

**SANYO Electric Co., Ltd. Semiconductor Business Headquarters**

TOKYO OFFICE Tokyo Bldg., 1-10, 1 Chome, Ueno, Taito-ku, TOKYO, 110 JAPAN

LC7218, 7218M, 7218JM

Package Dimensions

unit: mm

3045B-MFP24

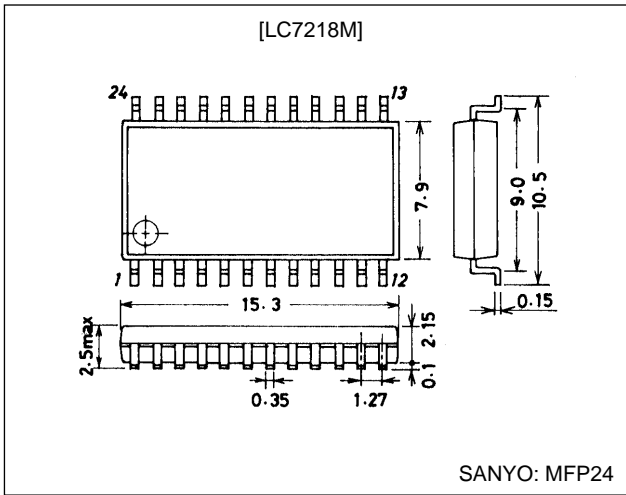

unit: mm

3112-MFP24S

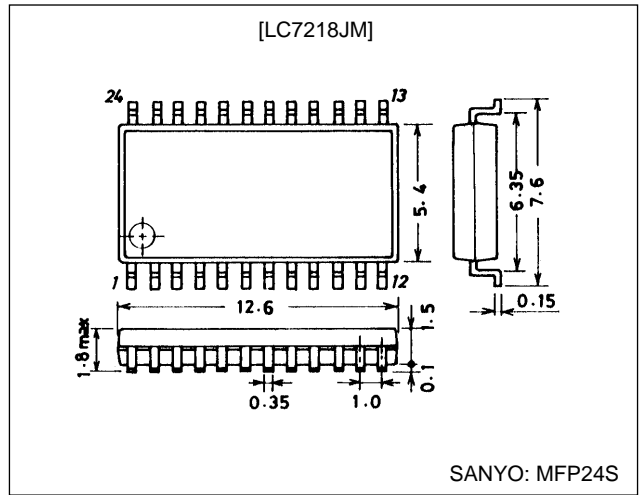

Pin Assignments

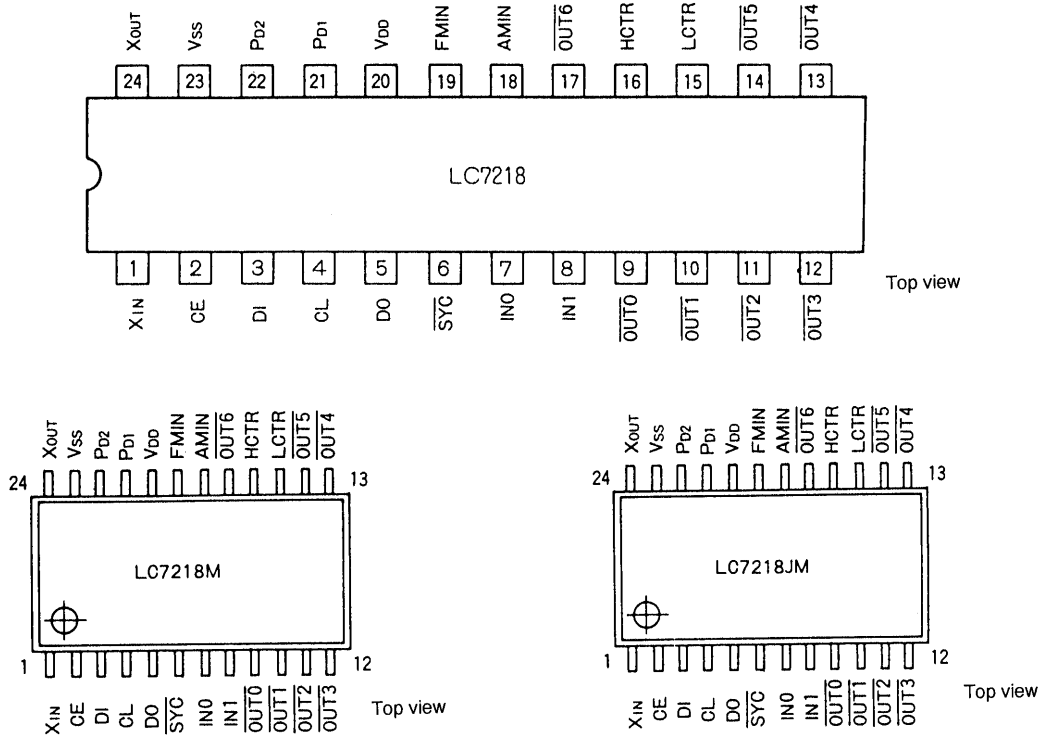

LC7218, 7218M, 7218JM

Block Diagram

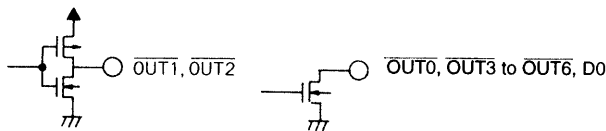
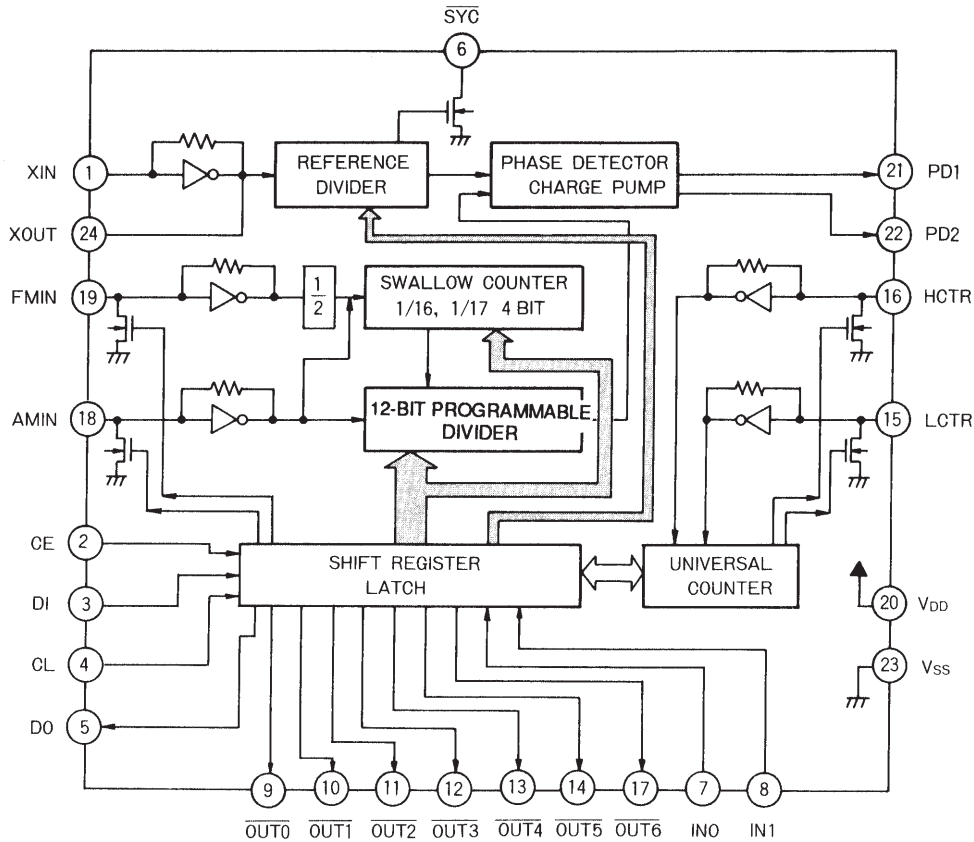

Note: Crystal oscillator example: 7.200 MHz, CL16pF (C = 27 pF)  
 • LN-X-0702(NR-18 type)  
 • LN-P-0001 (AT-51 type)

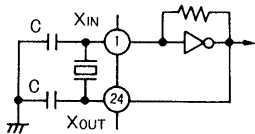

Manufactured by:  
 NIHON DENPA KOGYO CO., LTD.

Pin Symbols

- XIN, XOUT: Crystal oscillator (7.2 MHz)
- FMIN, AMIN: Local oscillator signal input
- CE, CL, DI, DO: Serial data I/O
- OUT0 to OUT6: Output ports
- IN0, IN1: Input ports
- HCTR, LCTR: General-purpose counter inputs
- PD1, PD2: Charge pump outputs
- SYC: Control clock (400 kHz)

Specifications

Absolute Maximum Ratings at Ta = 25°C, VSS = 0 V

Parameter	Symbol	Conditions	Ratings	Unit
Maximum supply voltage	V <sub>DD</sub> max	V <sub>DD</sub>	-0.3 to +7.0	V
Input voltage	V <sub>IN</sub> (1)	CE, CL, DI, IN0, IN1	-0.3 to +7.0	V
	V <sub>IN</sub> (2)	Input pins other than V <sub>IN</sub> (1)	-0.3 to V <sub>DD</sub> + 0.3	V
Output voltage	V <sub>OUT</sub> (1)	DO, SYC	-0.3 to +7.0	V
	V <sub>OUT</sub> (2)	OUT1, OUT2	-0.3 to V <sub>DD</sub> + 0.3	V
	V <sub>OUT</sub> (3)	OUT3 to OUT6, OUT0	-0.3 to +15	V
	V <sub>OUT</sub> (4)	Output pins other than V <sub>OUT</sub> (1), V <sub>OUT</sub> (2) and V <sub>OUT</sub> (3)	-0.3 to V <sub>DD</sub> + 0.3	V
Allowable power dissipation	Pd max	Ta ≤ 85°C :LC7218	350	mW
		:LC7218M	300	
		:LC7218JM	200	
Operating temperature	Topr		-40 to +85	°C
Storage temperature	Tstg		-55 to +125	°C

## LC7218, 7218M, 7218JM

## Pin Functions

Pin No.	Symbol	I/O	Type	Function
1 24	X <sub>IN</sub> X <sub>OUT</sub>	Input Output	Xtal OSC	<ul style="list-style-type: none"> <li>Connections for a 7.2 MHz crystal oscillator</li> </ul>
19	FMIN	Input	Local oscillator signal input	<ul style="list-style-type: none"> <li>FMIN is selected when DV in the serial input data is set to 1.</li> <li>Input frequency range: 10 to 130 MHz (70 mVrms minimum)</li> <li>The signal passes through an internal divide-by-two prescaler and is then supplied to the swallow counter.</li> <li>Although the divisor setting is in the range 256 to 65,536, the actual divisor will be twice the set value due to the presence of the internal divide-by-two prescaler.</li> </ul>
18	AMIN	Input	Local oscillator signal input	<ul style="list-style-type: none"> <li>AMIN is selected when DV in the serial input data is set to 0.</li> <li>When SP in the serial input data is set to 1: <ul style="list-style-type: none"> <li>Input frequency range: 2 to 40 MHz (70 mVrms minimum).</li> <li>The signal is supplied directly to the swallow counter without passing through the internal divide-by-two prescaler.</li> <li>The divisor setting is in the range 256 to 65,536 and the actual divisor will be the value set.</li> </ul> </li> <li>When SP in the serial input data is set to 0: <ul style="list-style-type: none"> <li>Input frequency range: 0.5 to 10 MHz (70 mVrms minimum).</li> <li>The signal is supplied directly to a 12-bit programmable divider.</li> <li>The divisor setting is in the range 4 to 4,096 and the actual divisor will be the value set.</li> </ul> </li> </ul>
21 22	PD1 PD2	Three-state	Charge pump outputs	<ul style="list-style-type: none"> <li>PLL charge pump outputs. High levels are output from PD1 and PD2 when the local oscillator frequency divided by n is higher than the reference frequency, and low levels are output when that frequency is lower than the reference frequency. These pins go to the floating state when the frequencies agree.</li> </ul>
6	$\overline{\text{SYC}}$	N-channel open drain	Controller clock	<ul style="list-style-type: none"> <li>SYC is a controller clock source. The LC7218 outputs a 400 kHz 66% duty signal from this pin after power is applied.</li> </ul>
20	V <sub>DD</sub>	—	Power supply	<ul style="list-style-type: none"> <li>The LC7218 power supply pin. A voltage of between 4.5 and 6.5 V must be provided when the PLL is operating. The supply voltage can be lowered to 3.5 V when only operating the crystal oscillator circuit to acquire the controller clock and the clock time base outputs.</li> </ul>
23	V <sub>SS</sub>	—	Ground	<ul style="list-style-type: none"> <li>The LC7218 ground pin</li> </ul>
2	CE	Input*	Chip enable	<ul style="list-style-type: none"> <li>This pin must be set high when inputting serial data (via DI) or when outputting serial data (via DO).</li> </ul>
4	CL	Input*	Clock	<ul style="list-style-type: none"> <li>The clock input used for data signal synchronization during serial data input (via DI) or output (via DO).</li> </ul>
3	DI	Input*	Input data	<ul style="list-style-type: none"> <li>Input pin used when transferring serial data from the controller to the LC7218.</li> <li>A total of 36 bits of data must be supplied to set up the LC7218 initial state.</li> </ul>
5	DO	Output (N-channel open drain)	Output data	<ul style="list-style-type: none"> <li>Output pin used when transferring serial data to the controller from the LC7218.</li> <li>A total of 28 bits from an internal shift register can be output in synchronization with the CL signal.</li> </ul>

Note: \* The high and low level input voltages for the CE, CL, DI, IN0 and IN1 pins are  $V_{IH} = 2.2$  to 6.5 V and  $V_{IL} = 0$  to 0.7 V, regardless of the power supply voltage  $V_{DD}$ .

Continued on next page.

LC7218, 7218M, 7218JM

Continued from preceding page.

Pin No.	Symbol	I/O	Type	Function
9 10 11 12 13 14 17	$\overline{\text{OUT0}}$ $\overline{\text{OUT1}}$ $\overline{\text{OUT2}}$ $\overline{\text{OUT3}}$ $\overline{\text{OUT4}}$ $\overline{\text{OUT5}}$ $\overline{\text{OUT6}}$	Output*1	Output port	<ul style="list-style-type: none"> <li>These pins latch bits <math>O_0</math> to <math>O_6</math> in the serial data transferred from the controller, invert that data and output the inverted data in parallel.</li> <li>The <math>\overline{\text{OUT0}}</math> pin can also be used to output an 8 Hz clock time base signal. (When TB is 1.)</li> <li><math>\overline{\text{OUT1}}</math> and <math>\overline{\text{OUT2}}</math> are complementary outputs.</li> <li><math>\overline{\text{OUT0}}</math>, <math>\overline{\text{OUT3}}</math>, <math>\overline{\text{OUT4}}</math>, <math>\overline{\text{OUT5}}</math> and <math>\overline{\text{OUT6}}</math> are N-channel open drain outputs that can handle up to 13 V.</li> </ul>
7 8	IN0 IN1	Input*2	Input port	<ul style="list-style-type: none"> <li>The values of the IN0 and IN1 input ports can be converted from parallel to serial and output from the DO output pin.</li> </ul>
16	HCTR	Input	General-purpose counter Frequency measurement signal input pin	<ul style="list-style-type: none"> <li>HCTR is selected when SC in the serial input data is set to 1.</li> <li>Input frequency range: 10 to 60 MHz (70 mVrms minimum)</li> <li>The signal is supplied to a general-purpose 20-bit binary counter after passing through a divide-by-eight circuit. Therefore, the value of the counter is 1/8 of the frequency actually input to HCTR.</li> <li>When HCTR is selected the LC7218 will function in frequency measurement mode and the measurement period can be selected to be either 60 or 120 ms. (GT = 0: 60 ms, 1: 120 ms)</li> <li>The result of the measurement (the value of the general-purpose counter) can be output MSB first from the DO output pin.</li> </ul>
15	LCTR	Input	General-purpose counter Frequency or period measurement signal input pin	<ul style="list-style-type: none"> <li>LCTR is selected when SC in the serial input data is set to 0.</li> <li>When SF in the serial input data is set to 1:                             <ul style="list-style-type: none"> <li>Frequency measurement mode is selected.</li> <li>Input frequency range: 15 to 500 kHz (70 mVrms minimum).</li> <li>The signal is supplied directly to the general-purpose counter without passing through the internal divide-by-eight circuit.</li> <li>The measurement period is the same as for HCTR.</li> </ul> </li> <li>When SF in the serial input data is set to 0:                             <ul style="list-style-type: none"> <li>Period measurement mode is selected.</li> <li>Input frequency range: 1 Hz to 20 kHz (<math>V_{IH} = 0.7 V_{DD}</math> minimum, <math>V_{IL} = 0.3 \cdot V_{DD}</math> maximum)</li> <li>The measurement can be selected to be for one or two cycles. If two cycle measurement is selected the input frequency range becomes 2 Hz to 20 kHz. (GT = 0: one cycle, 1: two cycles)</li> </ul> </li> <li>Measurement results are output in the same manner as HCTR measurement results.</li> </ul>

Note: \*1. Since the output port states are undefined when power is first applied, transfer the control data quickly.  
 \*2. The high and low level input voltages for the CE, CL, DI, IN0 and IN1 pins are  $V_{IH} = 2.2$  to 6.5 V and  $V_{IL} = 0$  to 0.7 V, regardless of the power supply voltage  $V_{DD}$ .

Control Data Format (serial input data)

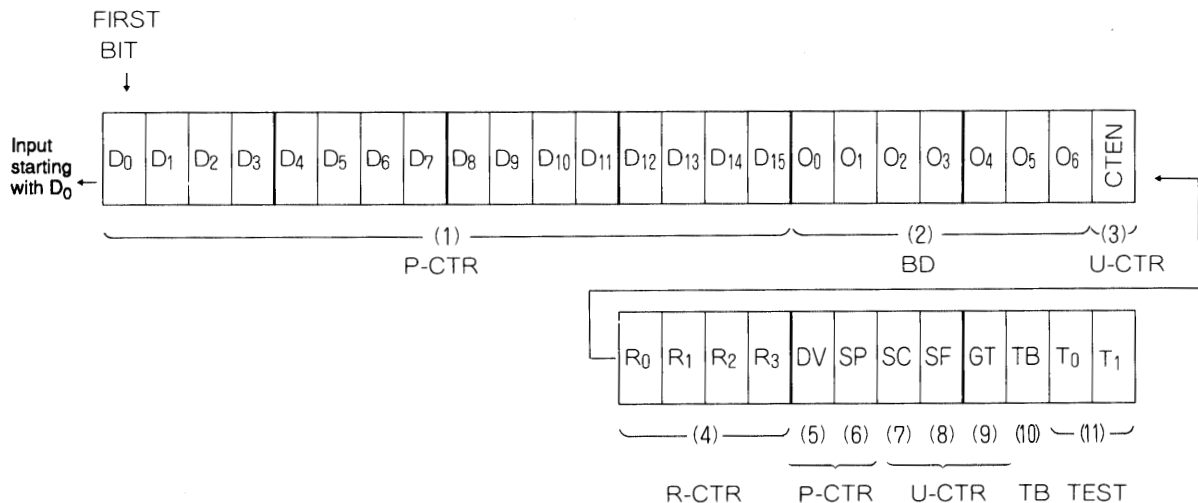



BR24C01A-W / BR24C01AF-W / BR24C01AFJ-W / BR24C01AFV-W / BR24C02-W / BR24C02F-W /

Memory ICs BR24C02FJ-W / BR24C02FV-W / BR24C04-W / BR24C04F-W / BR24C04FJ-W / BR24C04FV-W

# I<sup>2</sup>C BUS compatible serial EEPROM

## BR24C01A-W / BR24C01AF-W / BR24C01AFJ-W / BR24C01AFV-W / BR24C02-W / BR24C02F-W / BR24C02FJ-W / BR24C02FV-W / BR24C04-W / BR24C04F-W / BR24C04FJ-W / BR24C04FV-W

The BR24C01A-W, BR24C02-W, and BR24C04-W series are 2-wire (I<sup>2</sup>C BUS type) serial EEPROMs which are electrically programmable.

\* I<sup>2</sup>C BUS is a registered trademark of Philips.

### ●Applications

VCRs, TVs, printers, car stereos, cordless telephones, short wave radios, programmable DIP switches

### ●Features

- 1) 128×8bits (1k) serial EEPROM.  
(BR24C01A-W / AF-W / AFJ-W / AFV-W)
- 256×8bits (2k) serial EEPROM.  
(BR24C02-W / F-W / FJ-W / FV-W)
- 512×8bits (4k) serial EEPROM.  
(BR24C04-W / F-W / FJ-W / FV-W)
- 2) Two wire serial interface.
- 3) Operating voltage range : 2.7V~5.5V
- 4) Low current consumption  
Active (at 5V) : 1.5mA (Typ.)  
Standby (at 5V) : 0.1μA (Typ.)
- 5) Auto erase and auto complete functions can be used during write operations.
- 6) Page write function.  
BR24C01A-W / AF-W / AFJ-W / AFV-W : 8 bytes  
BR24C02-W / F-W / FJ-W / FV-W : 8 bytes  
BR24C04-W / F-W / FJ-W / FV-W : 16 bytes
- 7) DATA security  
Write protect feature  
Inhibit to WRITE at low V<sub>CC</sub>
- 8) Noise filters at SCL and SDA pins.
- 9) Address can be incremented automatically during read operations.
- 10) Compact packages.
- 11) Rewriting possible up to 100,000 times
- 12) Data can be stored for ten years without corruption.

### ●Absolute maximum ratings (Ta = 25°C)

Parameter	Symbol	Limits	Unit
Applied voltage	V <sub>CC</sub>	-0.3~+6.5	V
Power dissipation	Pd	300(SSOP-B8) *1	mW
		450(SOP8, SOP-J8) *2	
		800(DIP8) *3	
Storage temperature	T <sub>stg</sub>	-65~+125	°C
Operating temperature	T <sub>opr</sub>	-40~+85	°C
Input voltage	-	-0.3~V <sub>CC</sub> +0.3	V

\*1 Reduced by 3.0mW for each increase in Ta of 1°C over 25°C.

\*2 Reduced by 4.5mW for each increase in Ta of 1°C over 25°C.

\*3 Reduced by 8.0mW for each increase in Ta of 1°C over 25°C.

BR24C01A-W / BR24C01AF-W / BR24C01AFJ-W / BR24C01AFV-W / BR24C02-W / BR24C02F-W /

**Memory ICs** BR24C02FJ-W / BR24C02FV-W / BR24C04-W / BR24C04F-W / BR24C04FJ-W / BR24C04FV-W

●Recommended operating conditions (Ta = 25°C)

Parameter	Symbol	Limits	Unit
Power supply voltage	V <sub>CC</sub>	2.7~5.5 (WRITE)	V
		2.7~5.5 (READ)	V
Input voltage	V <sub>IN</sub>	0~V <sub>CC</sub>	V

●Block diagram

BR24C01A-W / AF-W / AFJ-W / AFV-W

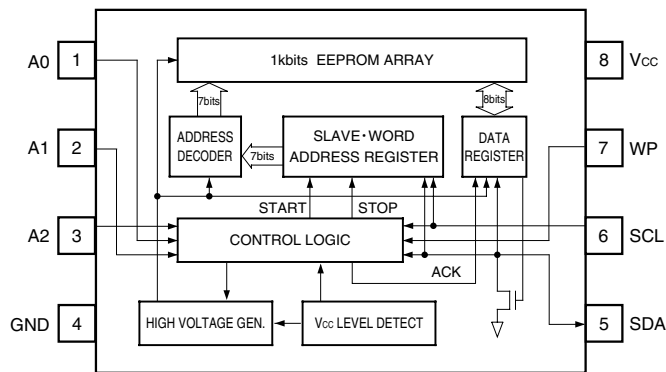

●Pin descriptions

Pin name	Function
A0, A1, A2	Slave address setting pin
SCL	Serial data clock
SDA	Serial data input / output *
WP	Write protect pin
V <sub>CC</sub>	Power supply
GND	Ground

\* An open drain output requires a pull-up resistor.

BR24C02-W / F-W / FJ-W / FV-W

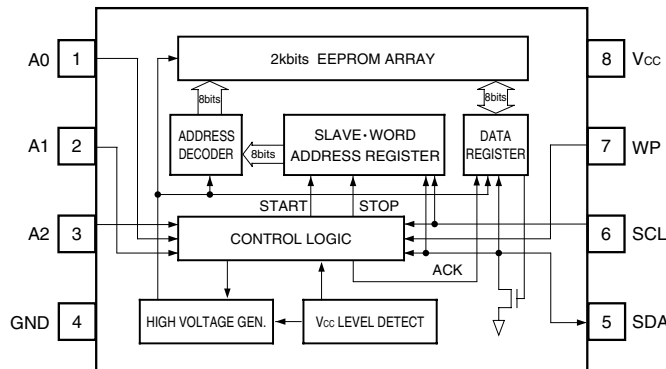

Pin name	Function
A0, A1, A2	Slave address setting pin
SCL	Serial data clock
SDA	Serial data input / output *
WP	Write protect pin
V <sub>CC</sub>	Power supply
GND	Ground

\* An open drain output requires a pull-up resistor.

BR24C04-W / F-W / FJ-W / FV-W

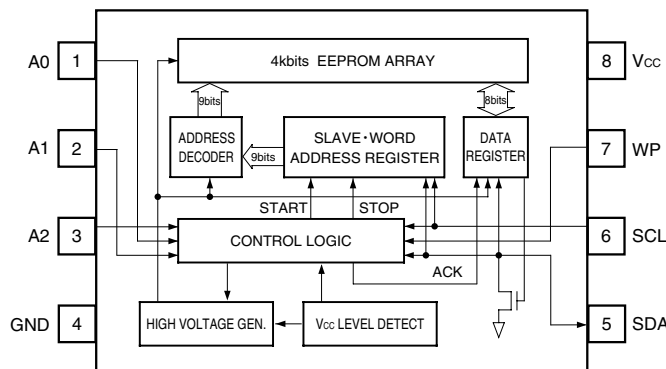

Pin name	Function
A0	N.C.
A1, A2	Slave address setting pin
SCL	Serial data clock
SDA	Serial data input / output *
WP	Write protect pin
V <sub>CC</sub>	Power supply
GND	Ground

\* An open drain output requires a pull-up resistor.

BR24C01A-W / BR24C01AF-W / BR24C01AFJ-W / BR24C01AFV-W / BR24C02-W / BR24C02F-W /

Memory ICs BR24C02FJ-W / BR24C02FV-W / BR24C04-W / BR24C04F-W / BR24C04FJ-W / BR24C04FV-W

●External dimensions (Units : mm)

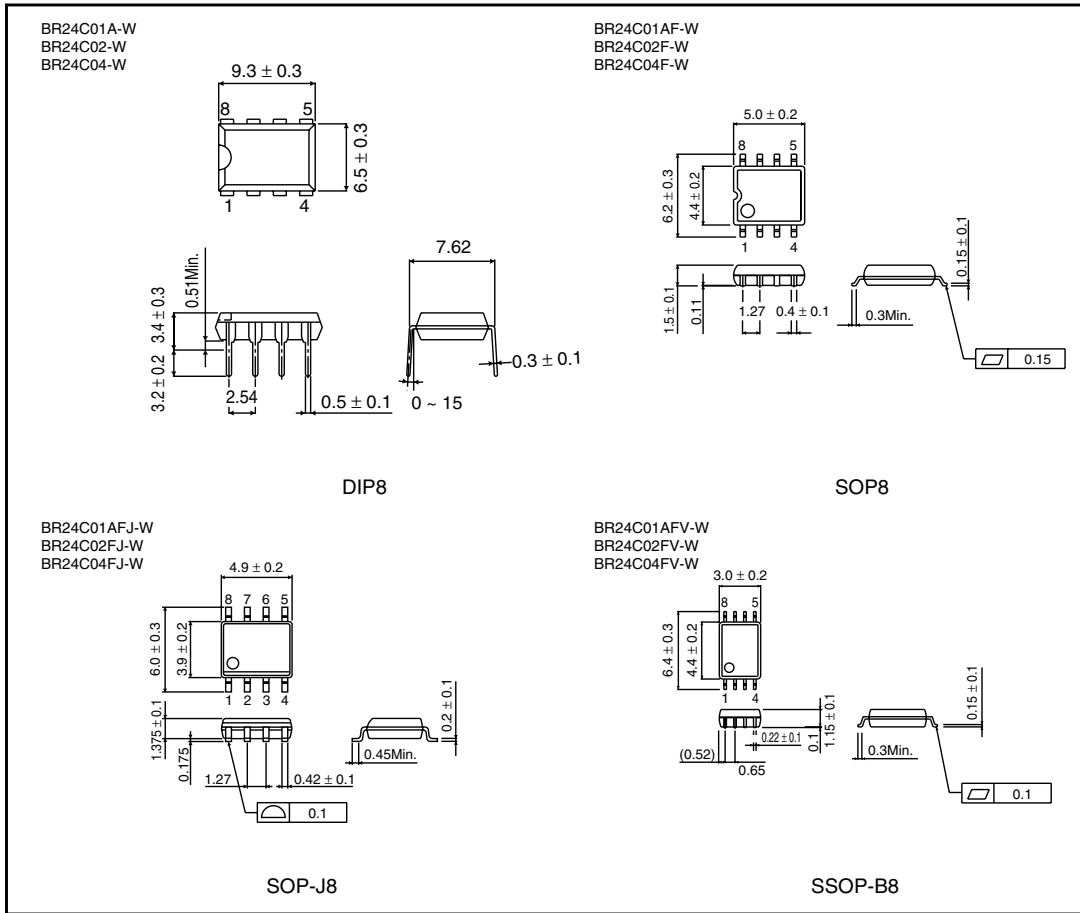

Monolithic Linear IC

**LA1266**

## AM/FM Tuner System Of Electronic Tuning Type

### Functions

FM: IF amplifier, quadrature detector, AF preamplifier, signal meter, IF count output, IF output, tuning indicator drive output (common with stop signal, muting drive output)

AM: RF amplifier, MIX, OSC (with ALC), IF amplifier, detector, AGC, signal meter, tuning indicator drive output (common with stop signal), IF count output, local OSC buffer.

### Features

- Minimum number of external parts required.
- Excellent S/N
- Local OSC with ALC
- Local OSC buffer
- Tuning indicator pin (common with narrow-band stop signal and muting drive output)
- Variable stop sensitivity (variable separately for FM, AM)
- Less tweet interference
- Signal meter pin
- IF count output

### Specifications

#### Maximum Ratings at $T_a=25^\circ\text{C}$

Parameter	Symbol	Conditions	Ratings	Unit
Maximum supply voltage	$V_{CC \text{ max}}$	Pins 7,8,20	16	V
Flow-in current	$I_8$	Pin 8	20	mA
Flow-out current	$I_{22}$	Pin 22	1	mA
	$I_{24}$	Pin 24	2	mA
Allowable power dissipation	$P_d \text{ max}$	$T_a \leq 60^\circ\text{C}$	700	mW
Operating temperature	$T_{opr}$		-20 to +70	$^\circ\text{C}$
Storage temperature	$T_{stg}$		-40 to +125	$^\circ\text{C}$

#### Operating Conditions at $T_a=25^\circ\text{C}$

Parameter	Symbol	Conditions	Ratings	Unit
Recommended supply voltage	$V_{CC}$		8.5	V
Operating voltage range	$V_{CC \text{ op}}$		6 to 14	V

### Package Dimensions

unit : mm

#### 3067-DIP24S

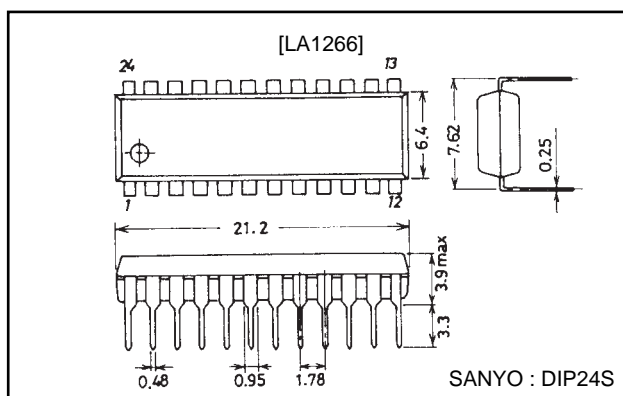

## LA1266

**Operating Characteristics** at  $T_a=25^\circ\text{C}$ ,  $V_{CC}=8.5\text{V}$ , See Test Circuit.

Parameter	Symbol	Conditions	Ratings			Unit
			min	typ	max	
[AM : $f_c=1\text{MHz}$ , $f_m=1\text{kHz}$ ]						
Quiescent current	$I_{CCO}$	No input		22	30	mA
Detection output	$V_{O1}$	$V_{IN}=20\text{dB}\mu$ , 30% mod.	30	60	110	mV
	$V_{O2}$	$V_{IN}=80\text{dB}\mu$ , 30% mod.	90	150	210	mV
Signal to noise ratio	S/N1	$V_{IN}=20\text{dB}\mu$	15	19		dB
	S/N2	$V_{IN}=80\text{dB}\mu$	49	54		dB
Total harmonic distortion	THD1	$V_{IN}=80\text{dB}\mu$ , 30% mod.		0.3	1.0	%
	THD2	$V_{IN}=107\text{dB}\mu$ , 30% mod.		0.3	1.0	%
Signal meter output	$V_{SM1}$	No input	0	0	0.2	V
	$V_{SM2}$	$V_{IN}=80\text{dB}\mu$	1.8	2.8	3.5	V
LED drive sensitivity	LED-ON	$I_{LED}=1\text{mA}$	13	23	33	dBm
Local OSC buffer output	$V_{OSC}$	$f_{osc}=1.45\text{MHz}$	220	280	340	mV
IF buffer output	$V_{IF}$	$V_{IN}=20\text{dB}\mu$	120	180	250	mV
[FM : $f_c=10.7\text{MHz}$ , $f_m=1\text{kHz}$ ]						
Quiescent current	$I_{CCO}$	No input		29	40	mA
Input limiting sensitivity	-3dBLS.	3dB down, 100% mod.		31	37	dB $\mu$
Demodulation output	$V_O$	$V_{IN}=100\text{dB}\mu$ , 100% mod.	270	390	540	mV
S/N ratio	S/N	$V_{IN}=100\text{dB}\mu$	78	84		dB
Total harmonic distortion	THD	$V_{IN}=100\text{dB}\mu$ , 100% mod.		0.03	0.3	%
Signal meter output	$V_{SM1}$	No input	0	0	0.2	V
	$V_{SM2}$	$V_{IN}=100\text{dB}\mu$	1.7	2.3	3.1	V
LED drive sensitivity	LED-ON	$I_{LED}=1\text{mA}$	46	61	76	dB $\mu$
LED drive bandwidth	LED-BW	$V_{IN}=100\text{dB}\mu$ , $I_{LED}=1\text{mA}$	70	105	140	kHz
AM rejection ratio	AMR	$V_{IN}=100\text{dB}\mu$ , 100% mod. AM-1kHz, 30% mod.	45	58		dB
IF buffer output	$V_{IF}$	$V_{IN}=50\text{dB}\mu$	110	160	230	mV

## Equivalent Circuit Block Diagram

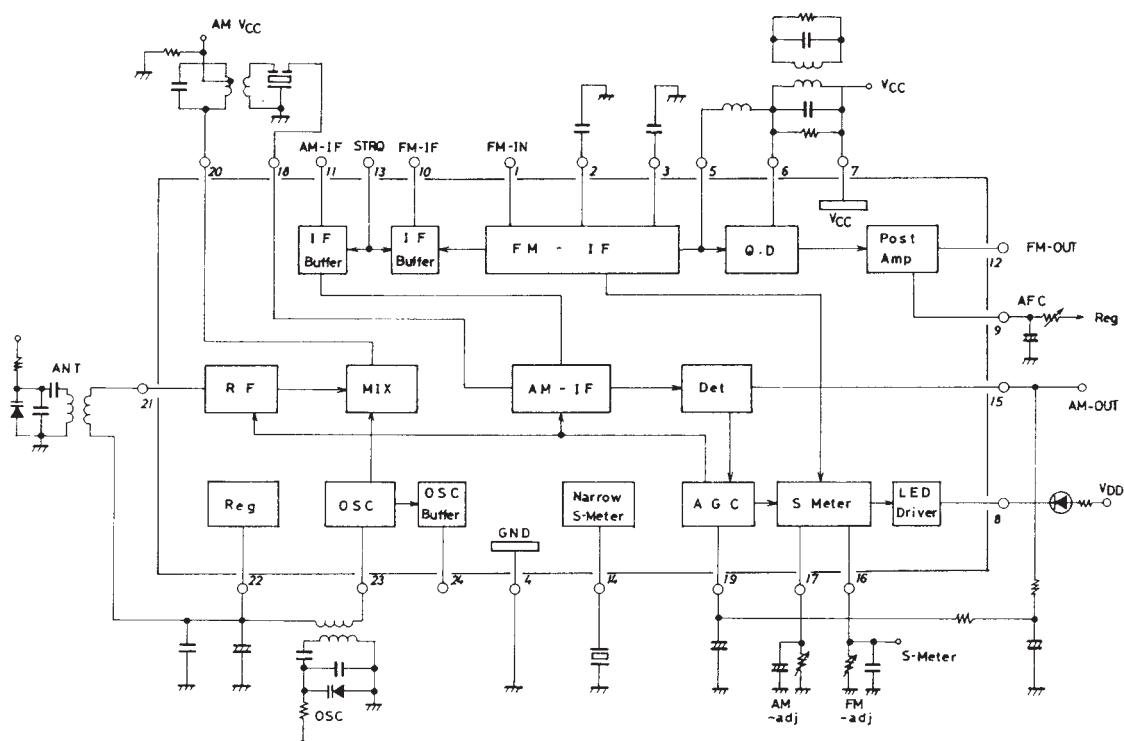

Front End : FE601 (FTA3-509HA) U.S.A. Version

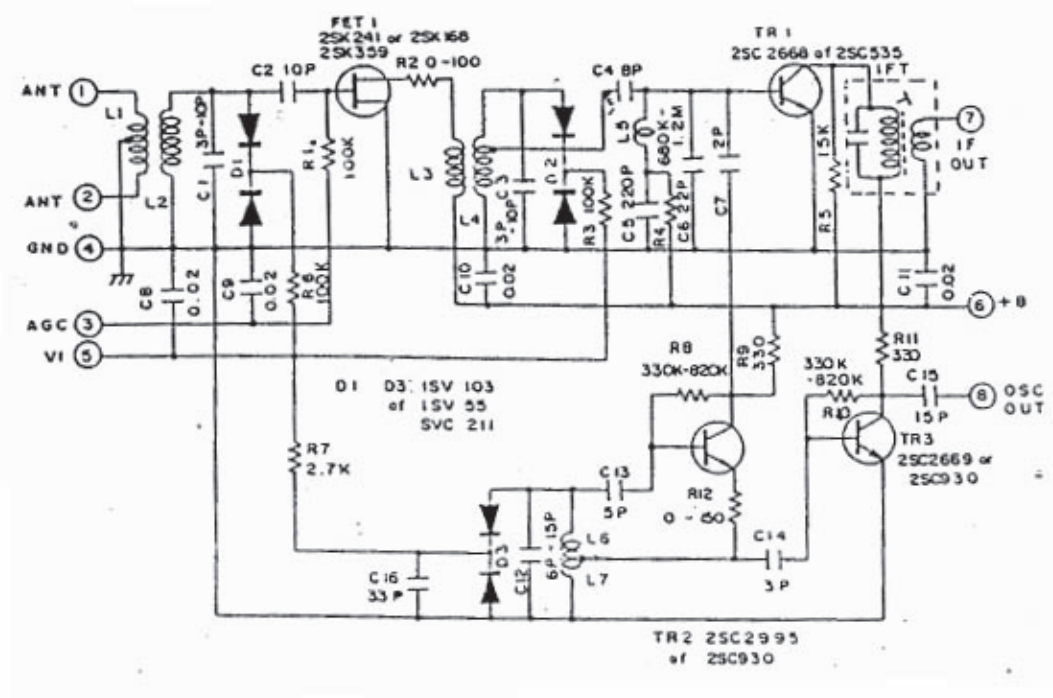

Front End : FE601 (FTA4-460H) E.U. Version

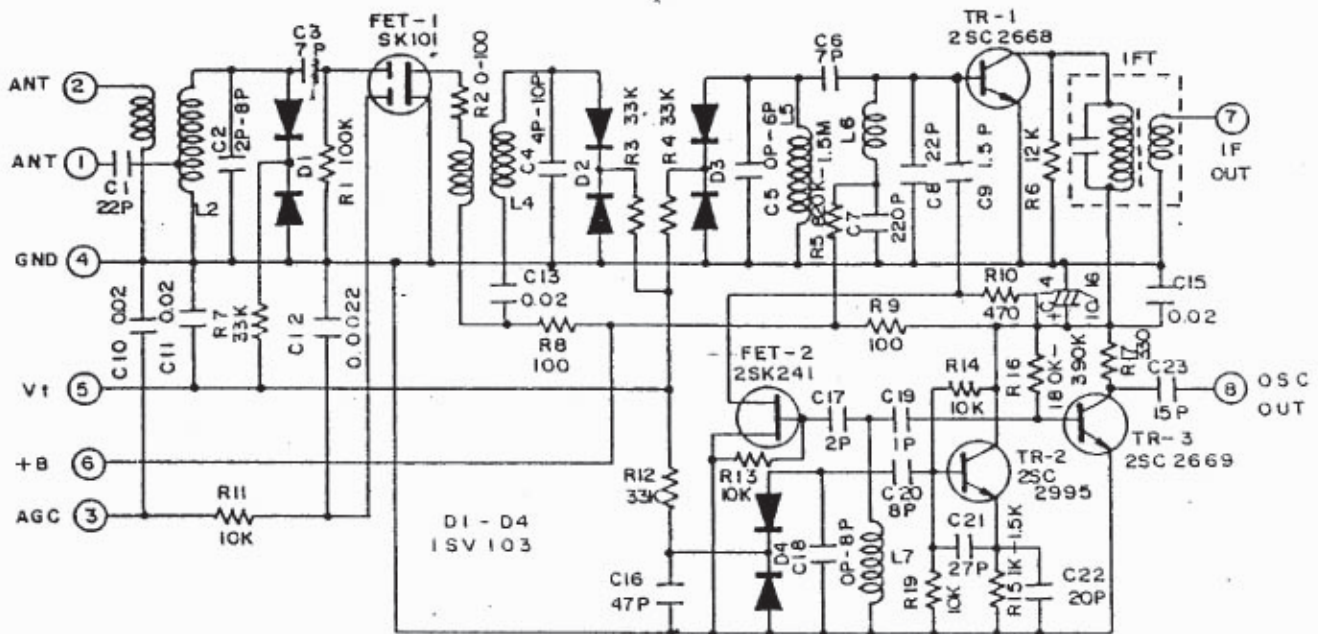

Silicon Transistor

2SA1859 PNP  
2SC4883 NPN

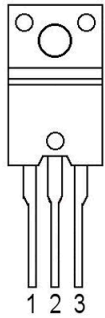

1 Base  
2 Collector  
3 Emitter

2SA1943  
2SC5200

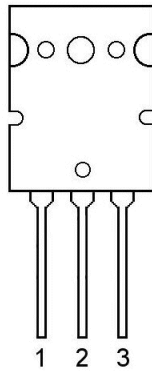

1 Base  
2 Collector (Heat Sink)  
3 Emitter

Silicon Transistor

2SA1492  
2SC3856

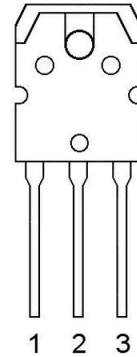

1 Base  
2 Collector (Heat Sink)  
3 Emitter

KTC3206

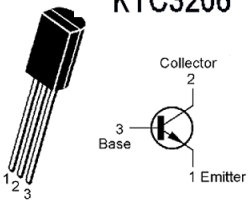

KTA1273

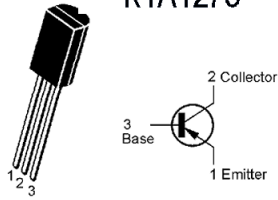

KRA107M  
KTA1268  
KTA1024

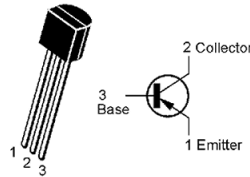

KTC3203  
KRC107  
KTC3200  
KTC3198  
KTD1302  
KTC3194

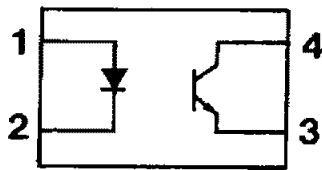
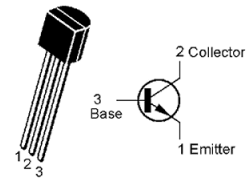

1. Anode  
2. Cathode  
3. Emitter  
4. Collector

2SC4137

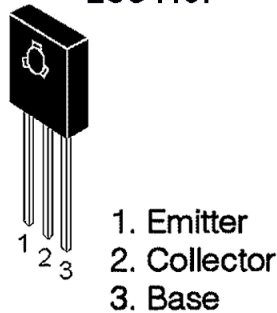

KA7805, 7815

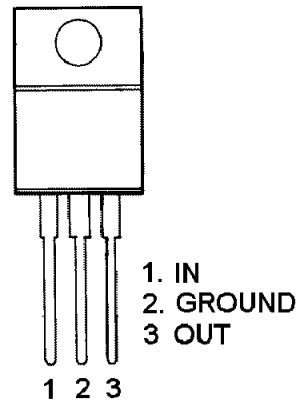

KA7915

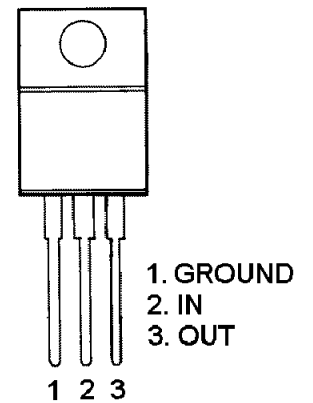

2SA1759

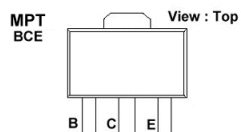

# 10. P. C. Board

12 | 11 | 10 | 9 | 8 | 7 | 6 | 5 | 4 | 3 | 2 | 1

P. C. BOARD  
MAIN

MAIN

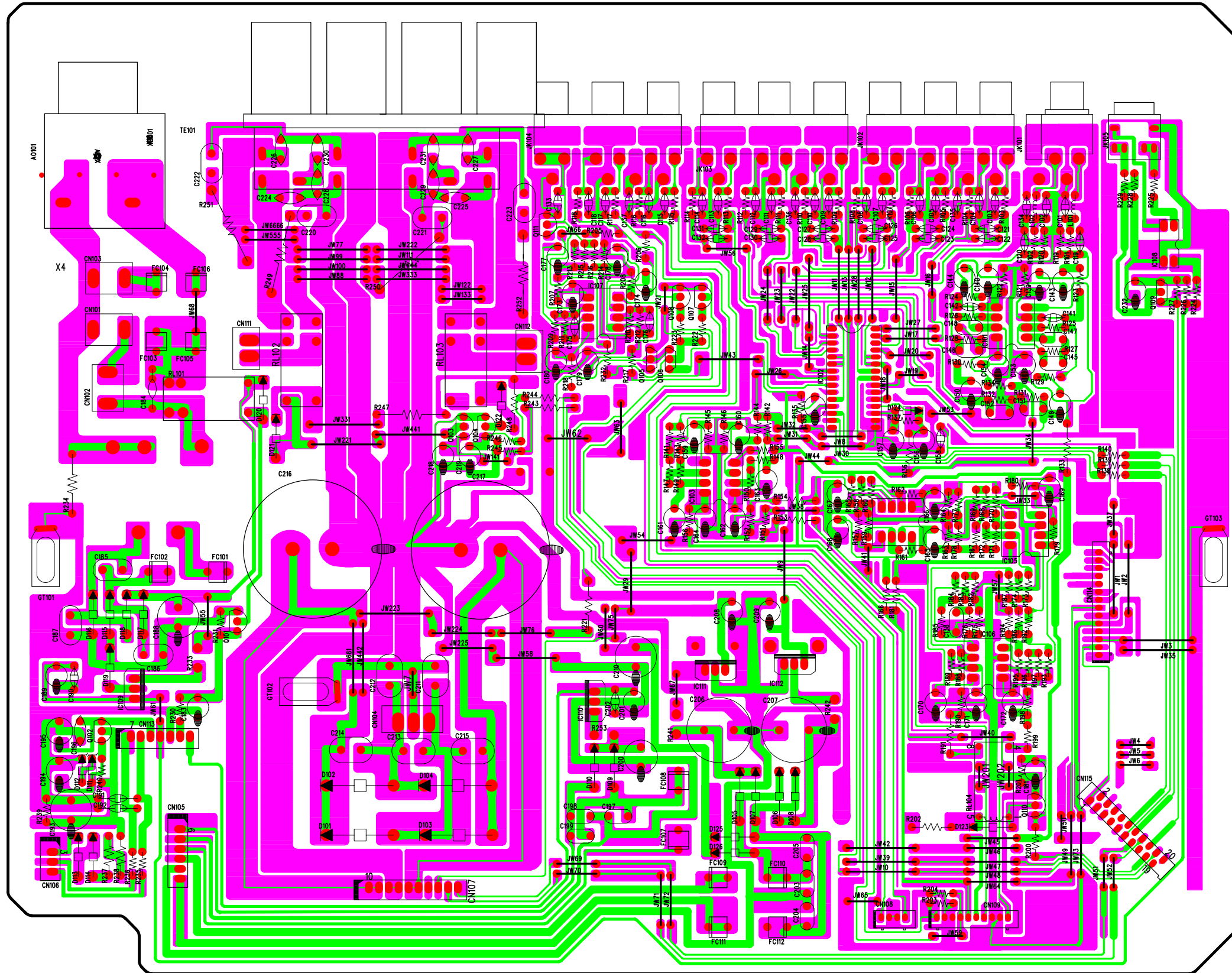

H  
G  
F  
E  
D  
C  
B  
A



P. C. BOARD  
AMP

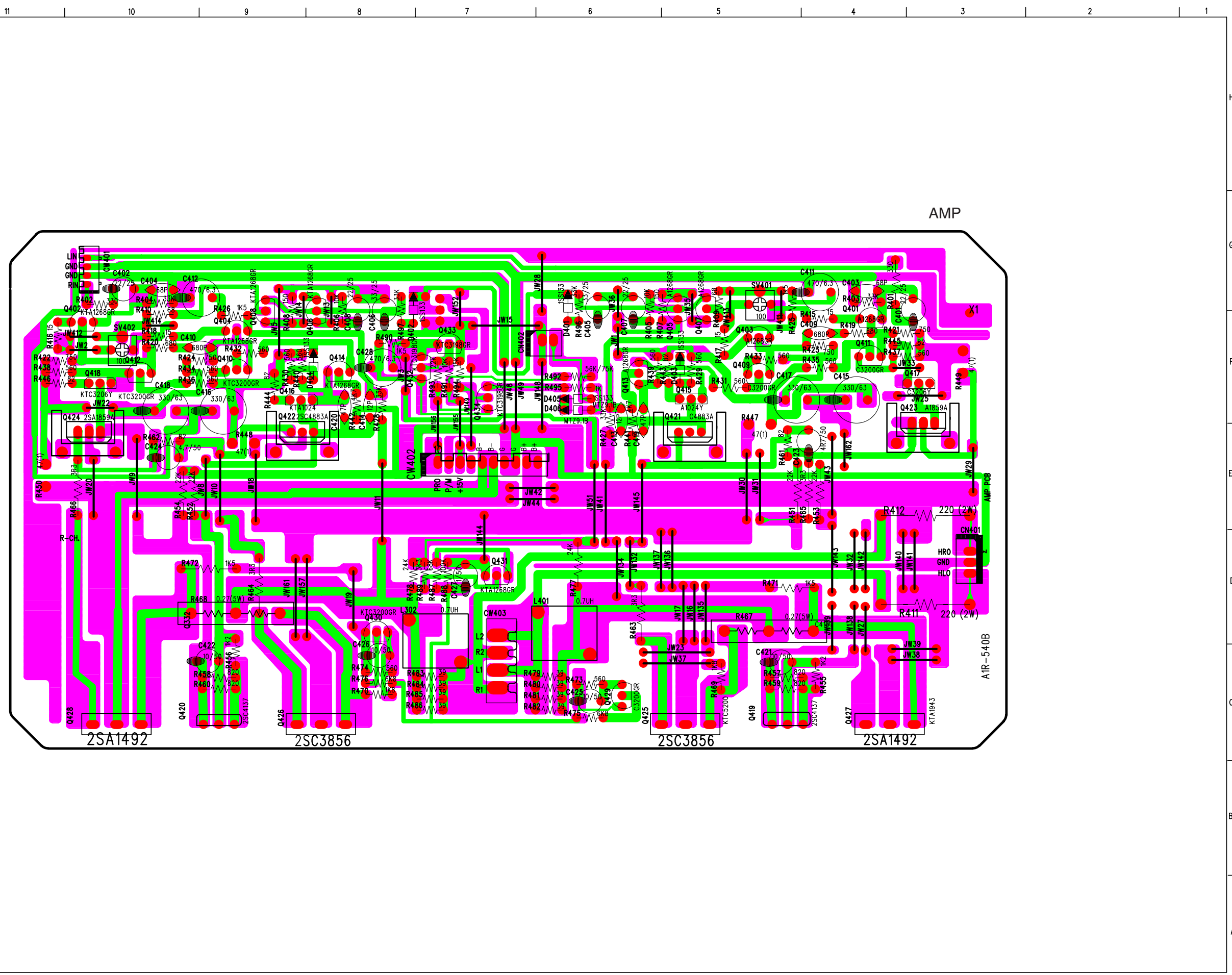

P. C. BOARD  
AMP

AMP

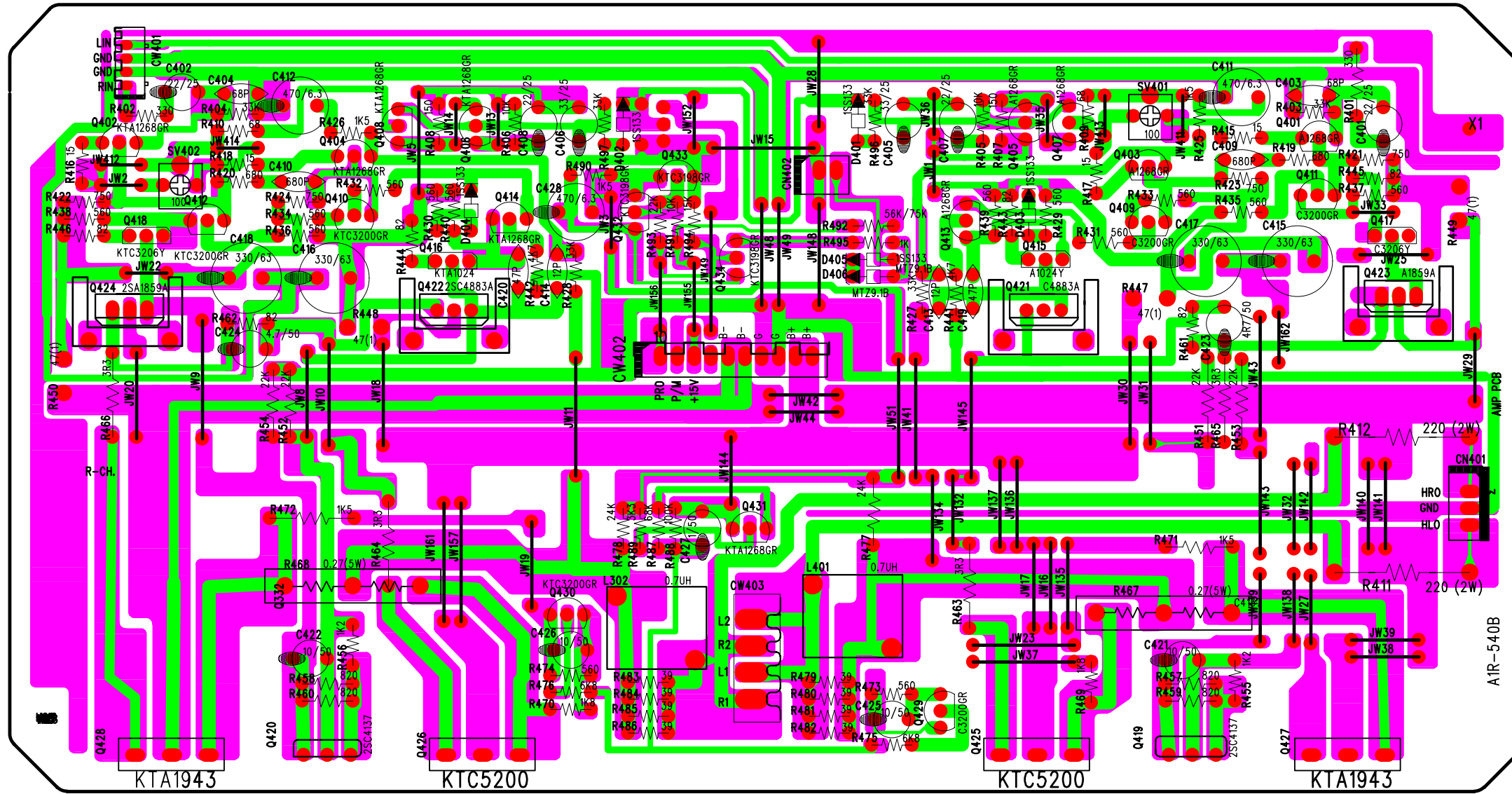

H  
G  
F  
E  
D  
C  
B  
A

P. C. BOARD  
FRONT

FRONT

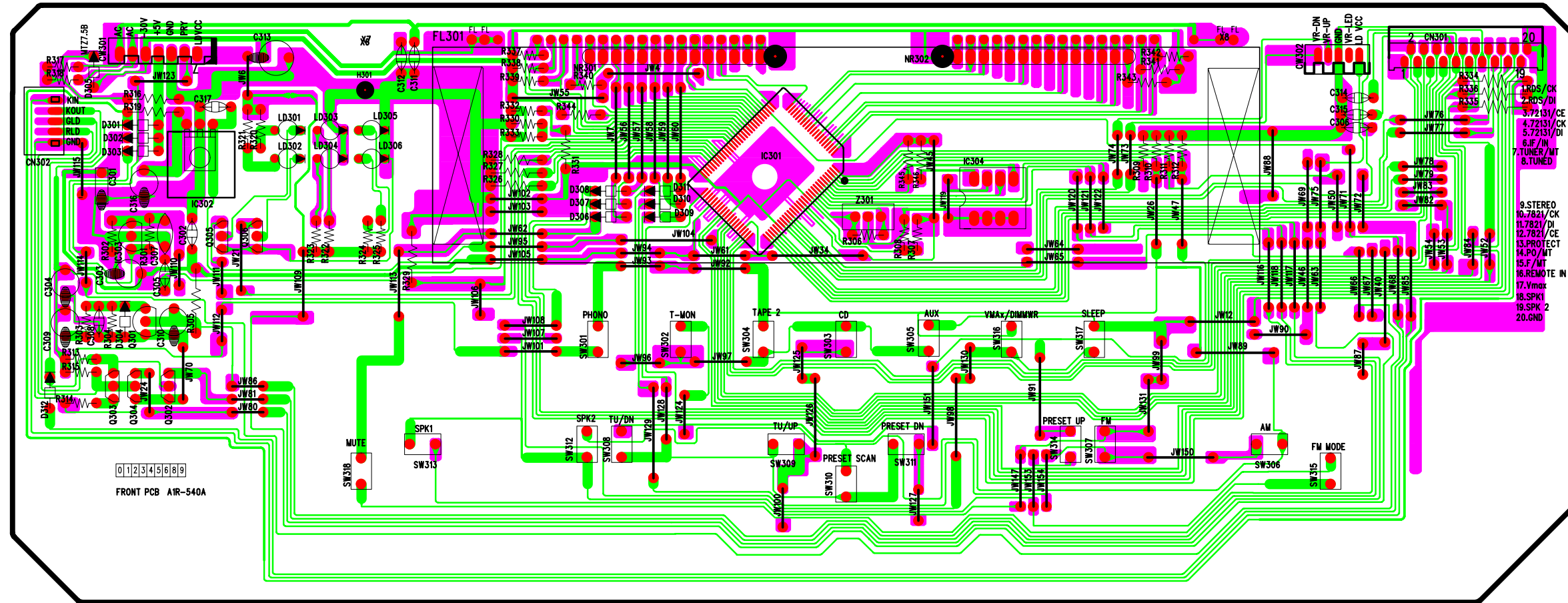

P. C. BOARD  
TUNER/VR/HP/COIL

12 11 10 9 8 7 6 5 4 3 2 1

H  
G  
F  
E  
D  
C  
B  
A

TUNER

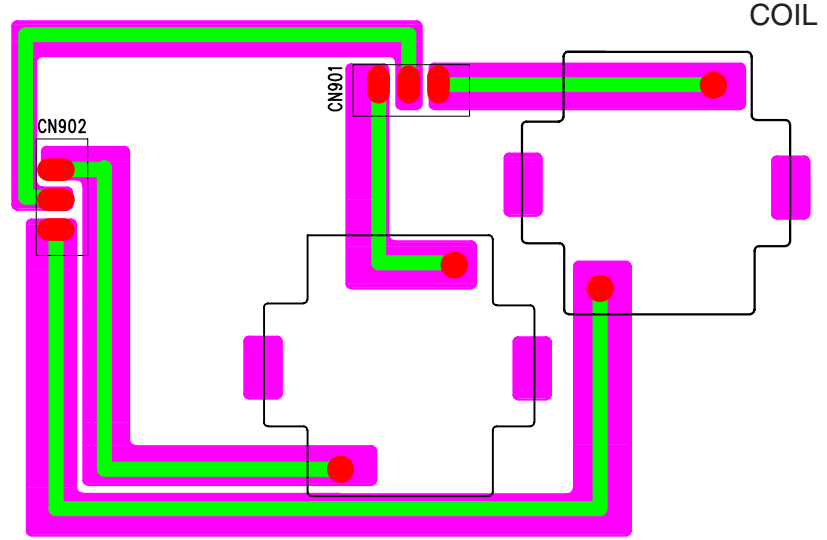
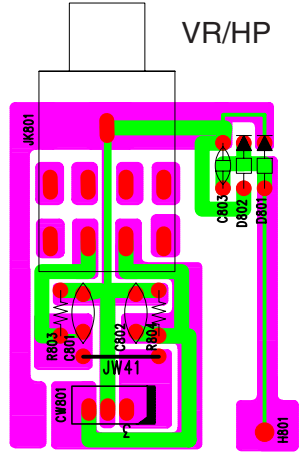
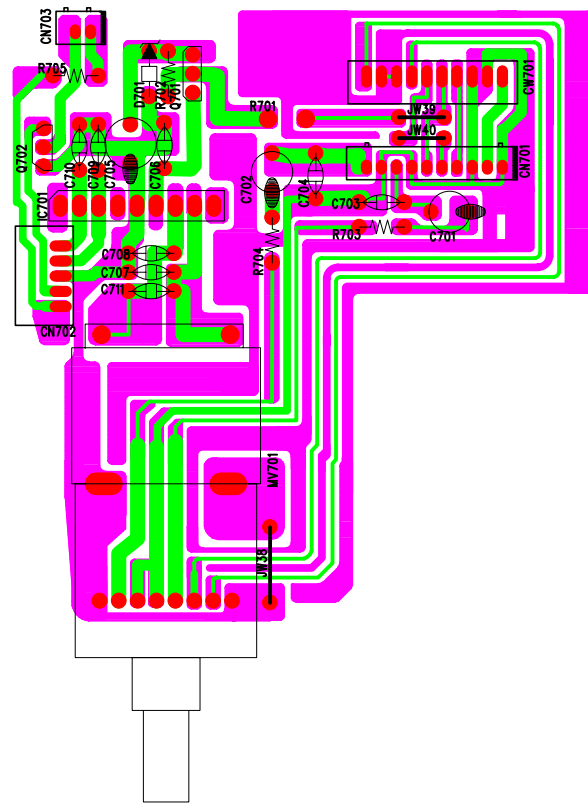
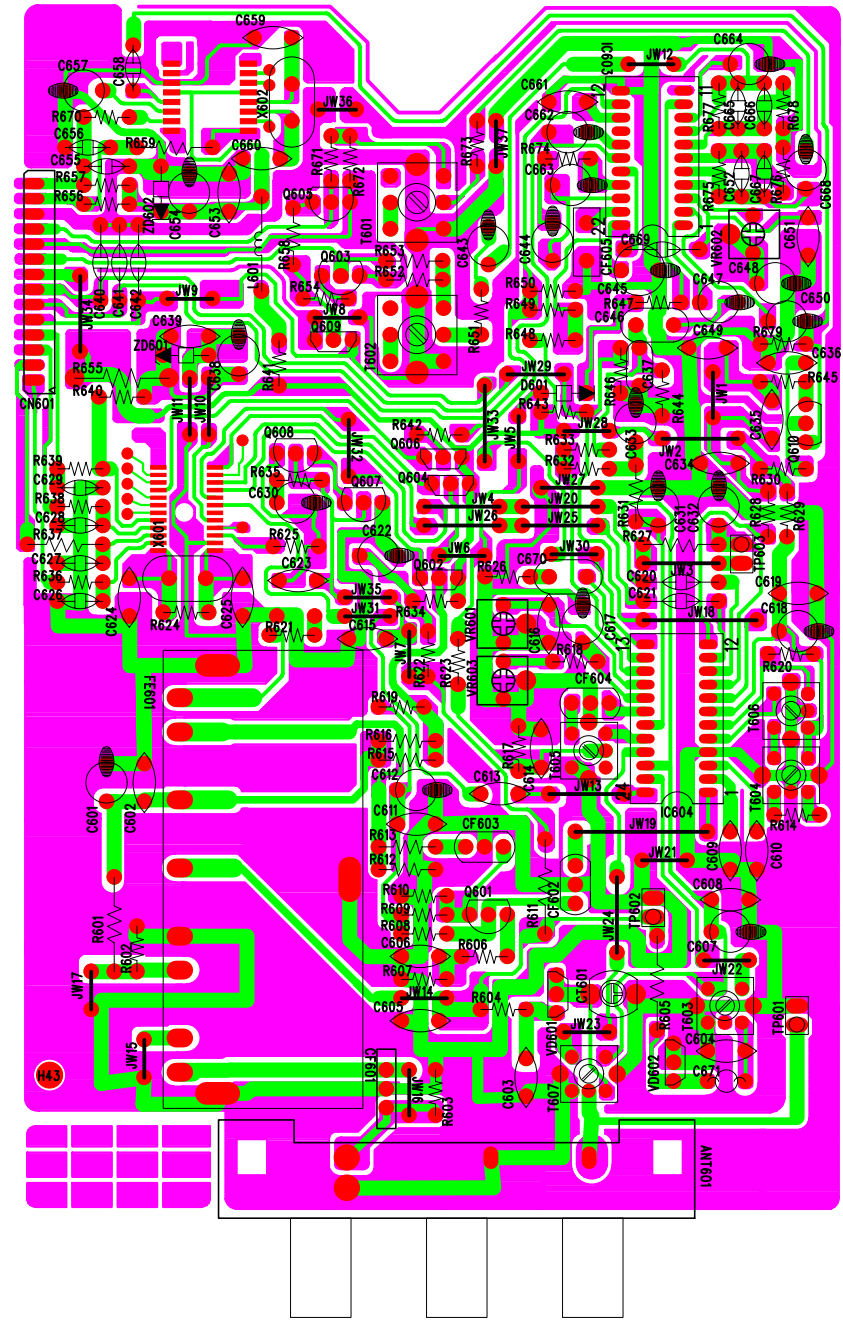

12 | 11 | 10 | 9 | 8 | 7 | 6 | 5 | 4 | 3 | 2 | 1

P. C. BOARD  
TONE/POWER SW/LED

H  
G  
F  
E  
D  
C  
B  
A

TONE

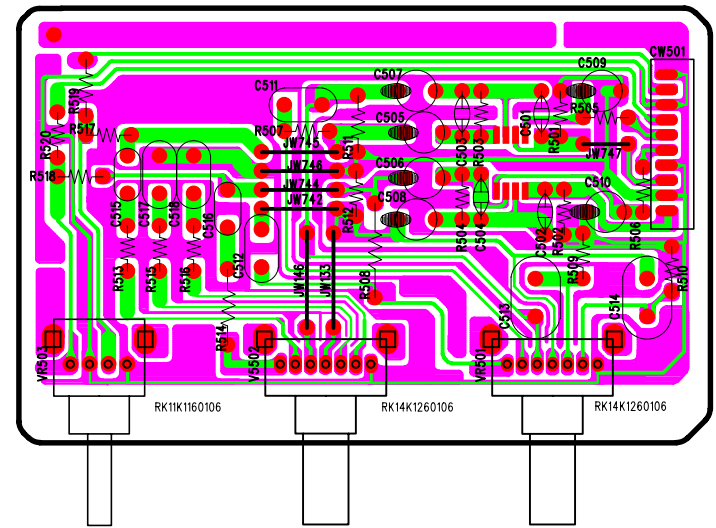

POWER SW / LED

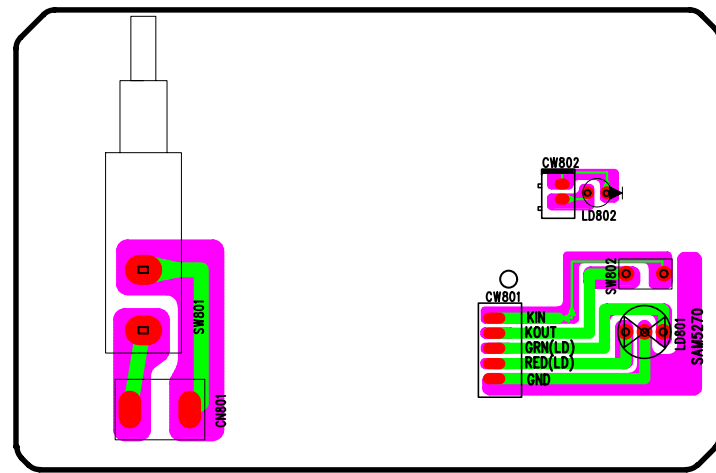

# 11. Schematic Diagram

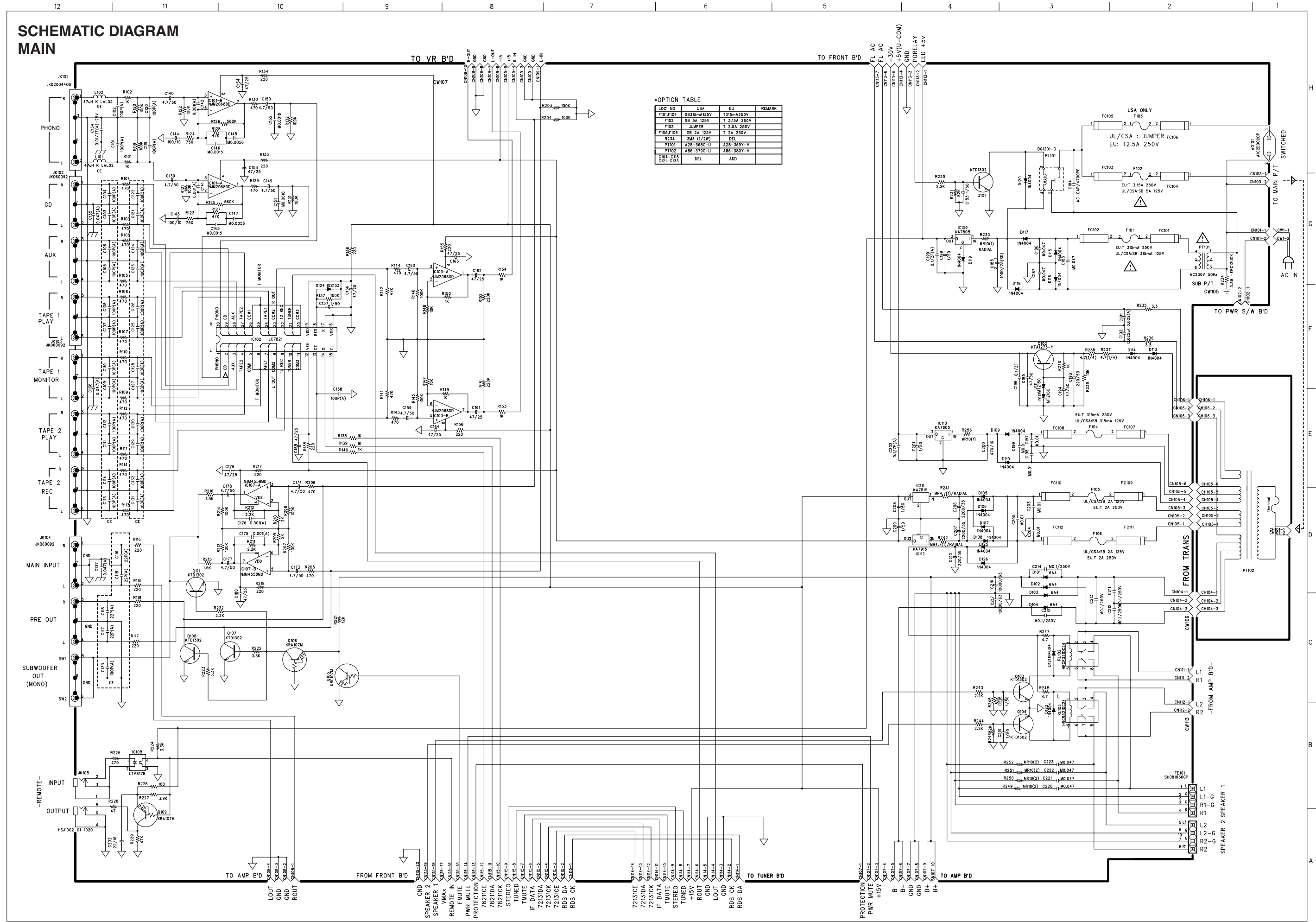

**\*OPTION TABLE**

LOC. NO.	USA	EU	REMARK
F101/F104	SB 5A 125V	1.35A 250V	
F102	SB 5A 125V	T 3.15A 250V	
F103	JUMPER	T 2.5A 250V	
F105/F108	SB 2A 125V	T 2A 250V	
R234	3M3 (1/2W)	DEL	
PT101	A28-368C-U	A28-368Y-V	
PT102	A86-379C-U	A86-380Y-V	
C104-C108	DEL	ADD	

# 11. Schematic Diagram

12 11 10 9 8 7 6

## SCHEMATIC DIAGRAM MAIN

### HK 3370

TO VR B'D

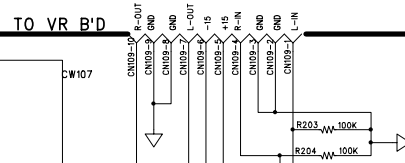

#### OPTION TABLE

LOC. NO	USA	EU	REMARK
F101,F104	SB515mA125V	T315mA250V	
F102	SB 5A 125V	T 3.15A 250V	
F103	JUMPER	T 2.5A 250V	
F105,F106	SB 2A 125V	T 2A 250V	
R234	3M3 (1/2W)	DEL	
PT101	A28-368C-U	A28-369Y-V	
PT102	A86-379C-U	A86-380Y-V	
C104-C108 C121-C133	DEL	ADD	

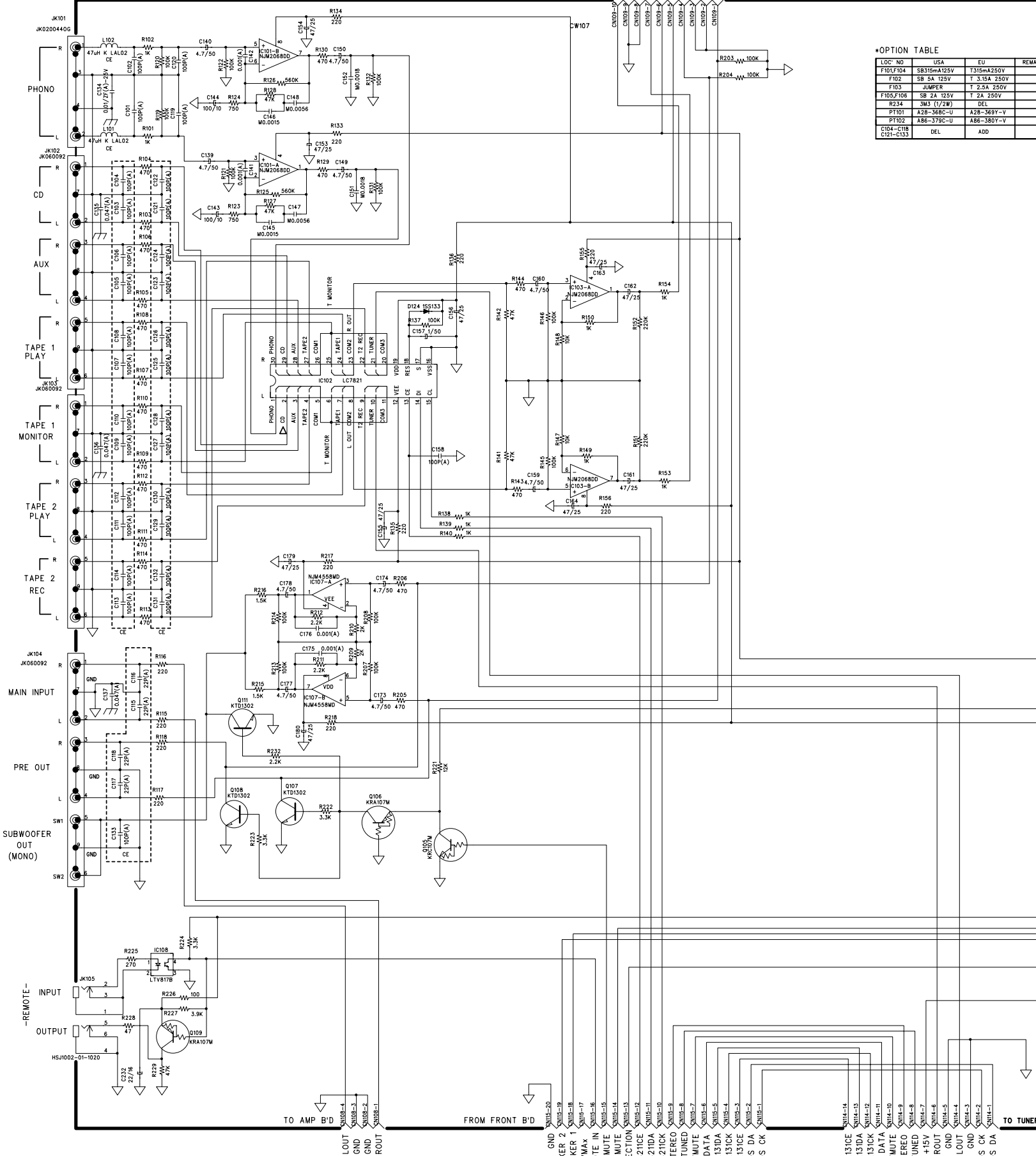

LOUT  
GND  
ROUT

TO AMP B'D



TO TUNER

6 5 4 3 2 1

\*OPTION TABLE

LOC. NO	USA	EU	REMARK
F101,F104	SB315mA125V	T315mA250V	
F102	SB 5A 125V	T 3.15A 250V	
F103	JUMPER	T 2.5A 250V	
F105,F106	SB 2A 125V	T 2A 250V	
R234	3M3 (1/2W)	DEL	
PT101	A28-368C-U	A28-369Y-V	
PT102	A86-379C-U	A86-380Y-V	
C104-C118	DEL	ADD	
C121-C133	DEL	ADD	

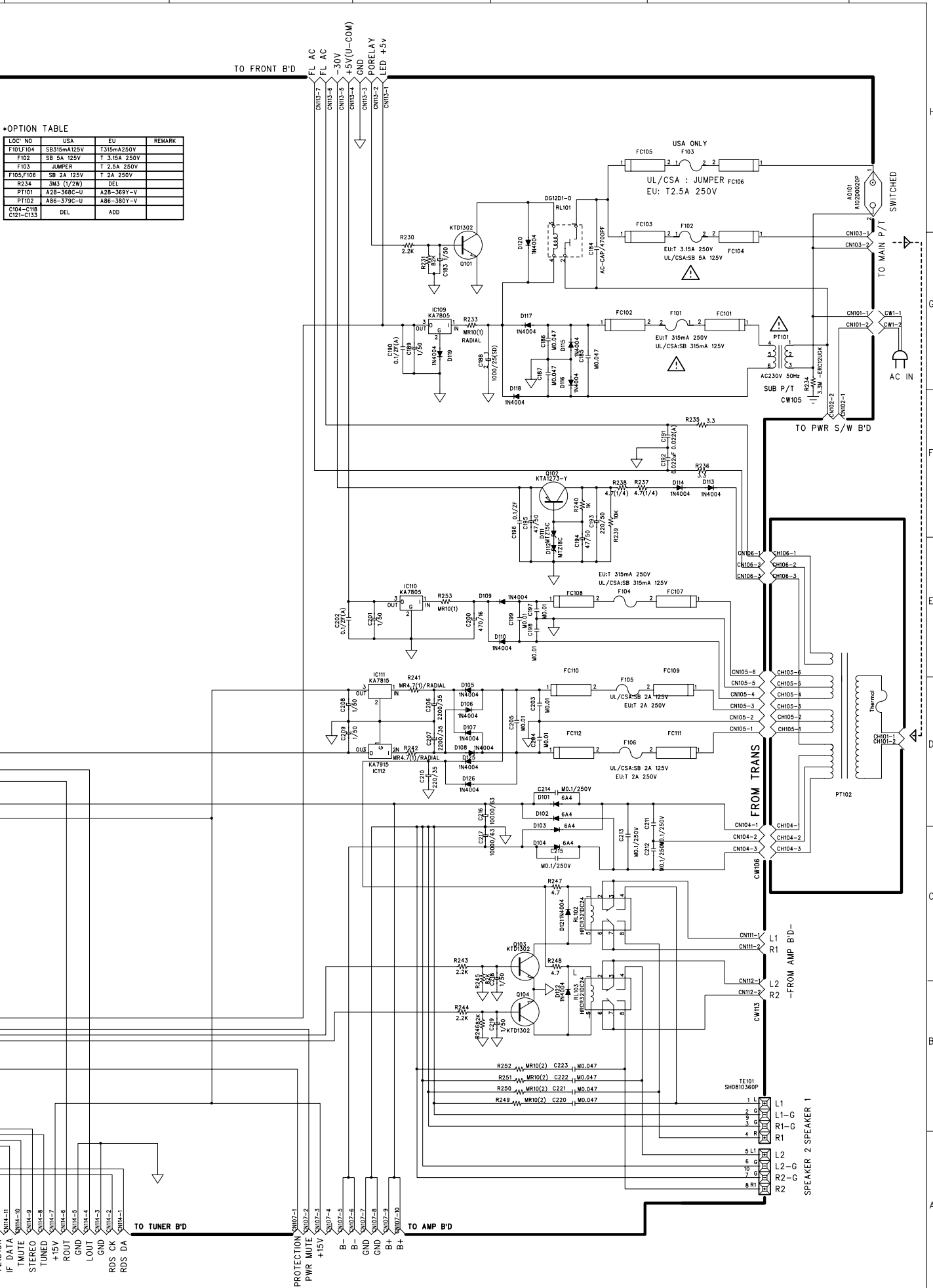

H  
G  
F  
E  
D  
C  
B  
A



# SCHEMATIC DIAGRAM MAIN

**\*OPTION TABLE**

LOC	USA	EU	REMARK
F10,F104	SB315A125V	T315A250V	
F102	SB 8A 125V	T 4A 250V	
F103	JUMPER	T 2.5A 250V	
F105,F106	SB 2A 125V	T 2A 250V	
R234	3M3 (1/2W)	DEL	
PT101	A28-369C-U	A28-369T-V	
PT102	A36-377C-U	A36-378V-V	
C103-C118	DEL	ADD	
C121-C133	DEL	ADD	
C224-C231	DEL	ADD	
EC90LEC902	DEL	ADD	

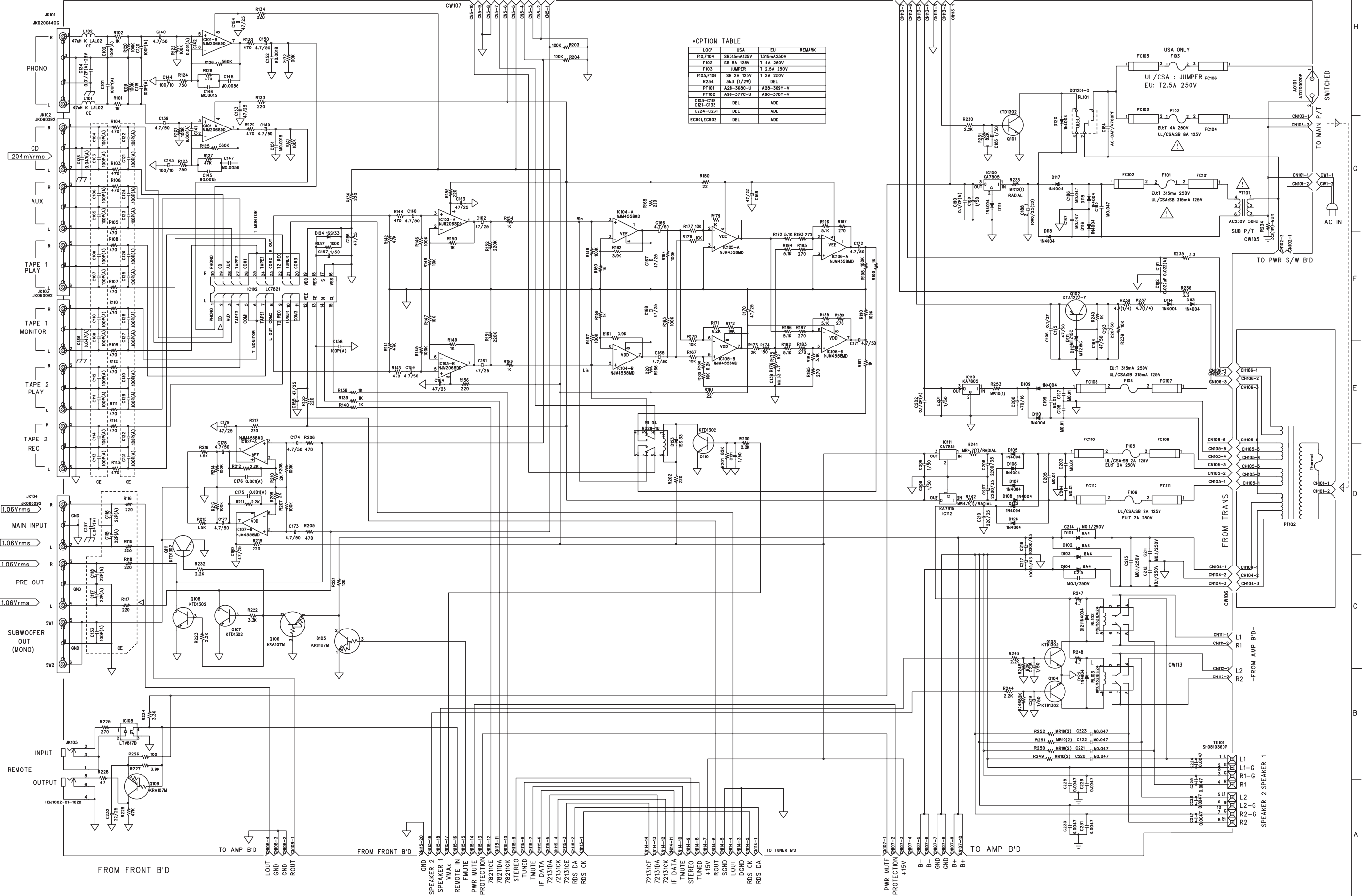

# SCHEMATIC DIAGRAM MAIN

**HK3470**

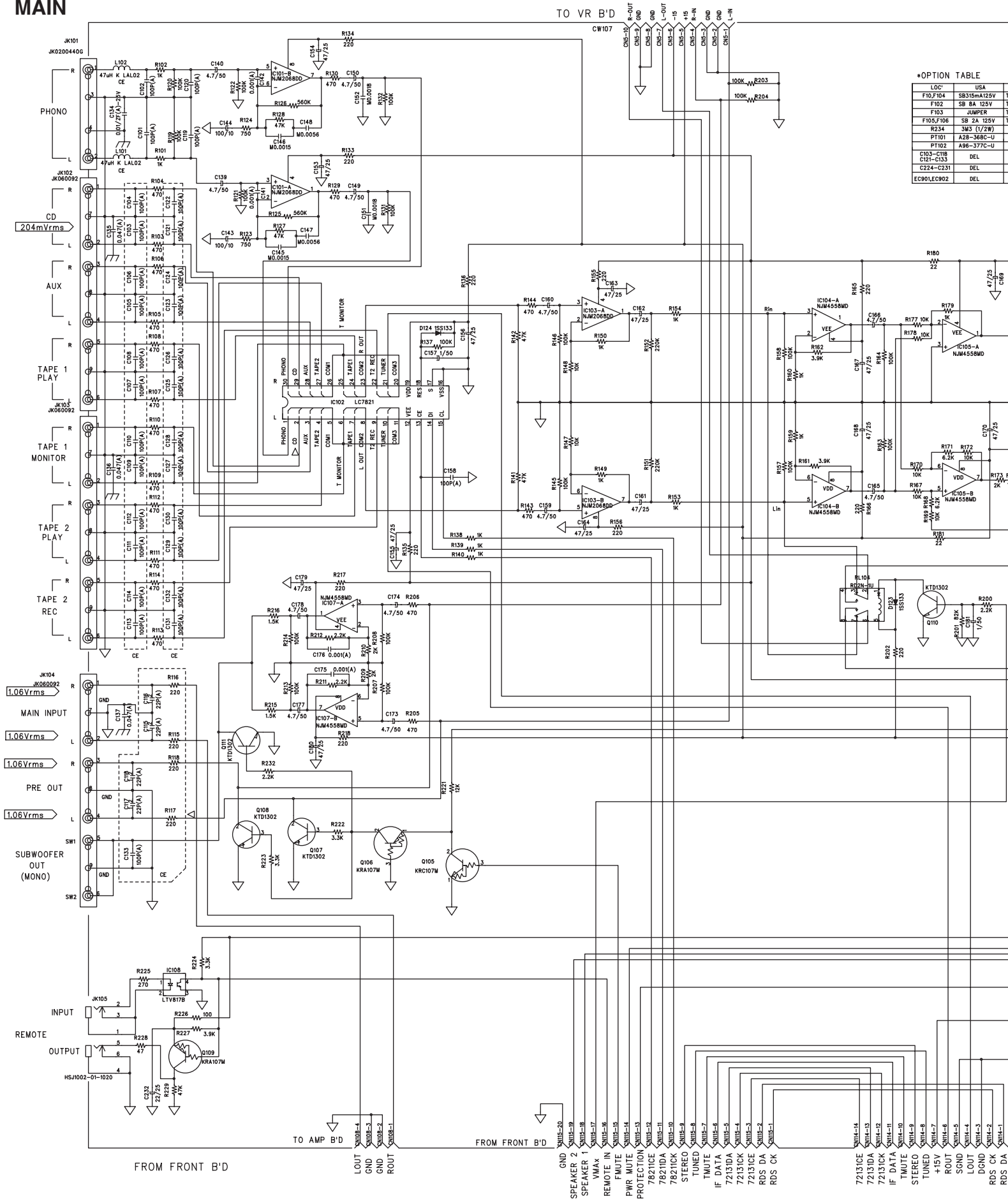

**\*OPTION TABLE**

LOC	USA	T3
F10,F104	SB315m125V	T
F102	SB 8A 125V	T
F103	JUMPER	T
F105,F106	SB 2A 125V	T
R234	3M3 (1/2W)	A
PT101	A28-368C-U	A
PT102	A96-377C-U	A
C103-C108	DEL	
C121-C133	DEL	
C224-C231	DEL	
EC901,EC902	DEL	

6 5 4 3 2 1

**\*OPTION TABLE**

LOC	USA	EU	REMARK
F10,F104	S835M425V	T315M4250V	
F102	SB 8A 125V	T 4A 250V	
F103	JUMPER	T 2.5A 250V	
F105,F106	SB 2A 125V	T 2A 250V	
R234	3M3 (1/2W)	DEL	
PT101	A28-369C-U	A28-369Y-Y	
PT102	A96-377C-U	A96-378Y-Y	
C103-C108	DEL	ADD	
C224-C231	DEL	ADD	
EC901,EC902	DEL	ADD	

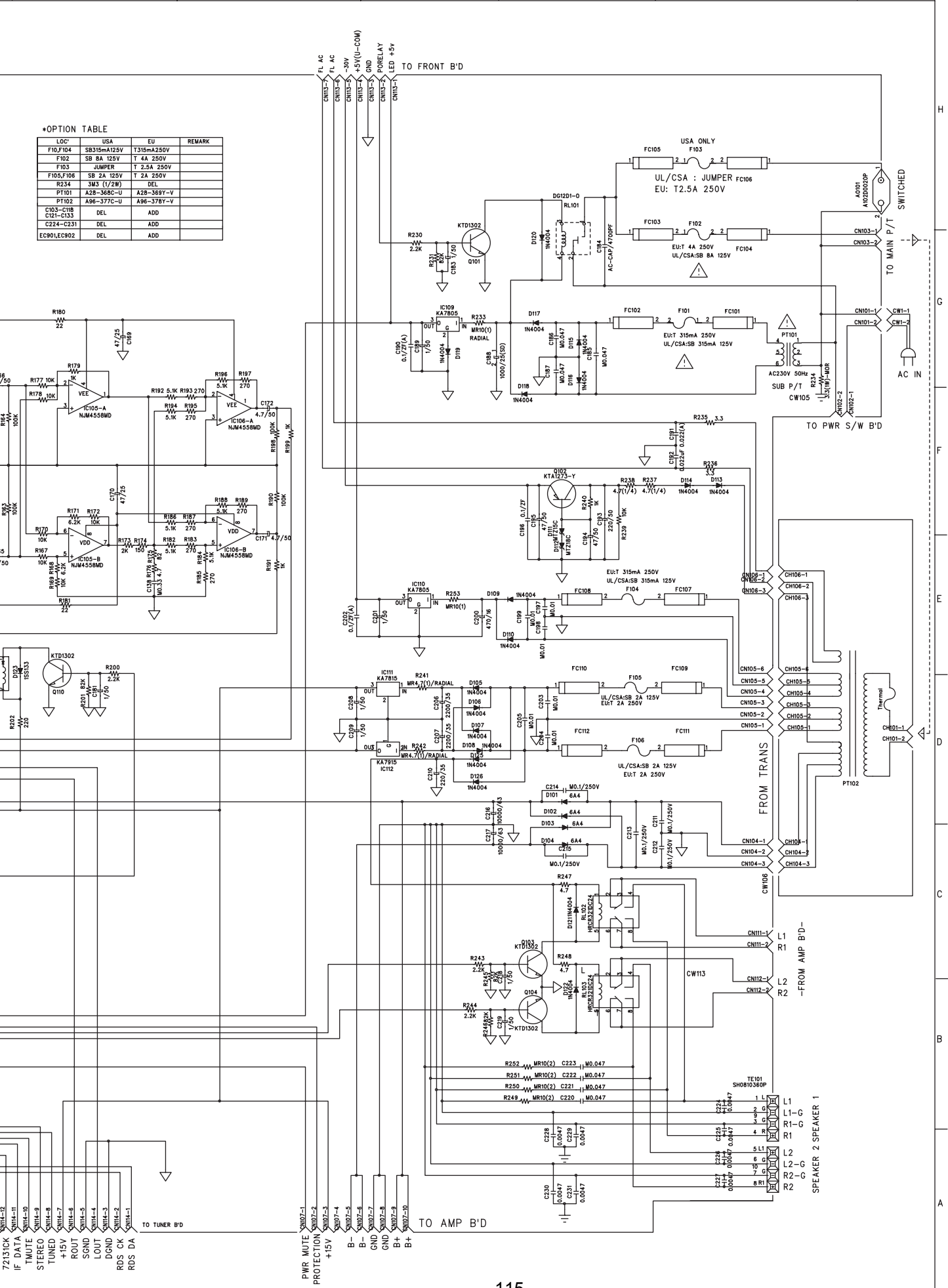

SCHEMATIC DIAGRAM  
AMP/TONE/ETC.

HK 3370 / HK 3470

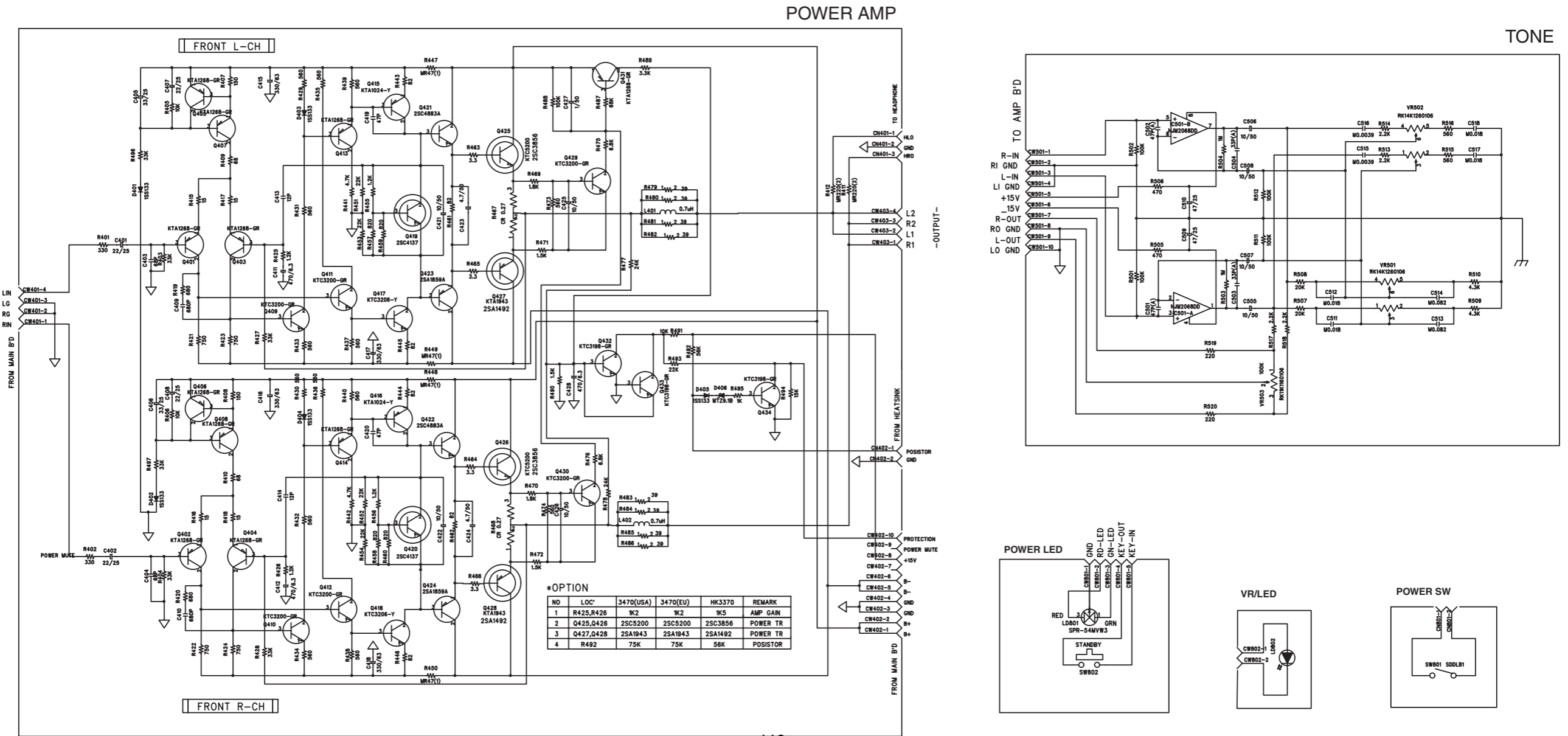

\*OPTION

NO	LC'	3470(USA)	3470(EU)	HK3370	REMARK
1	R425,R426	K2	K2	K5	AMP GAIN
2	Q425,Q426	2SC5200	2SC5200	2SC3856	POWER TR
3	Q427,Q428	2SA1943	2SA1943	2SA1492	POWER TR
4	R492	75K	75K	56K	POSISTOR

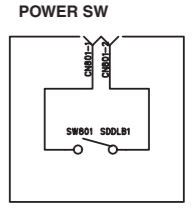
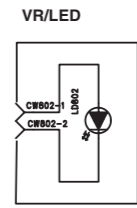
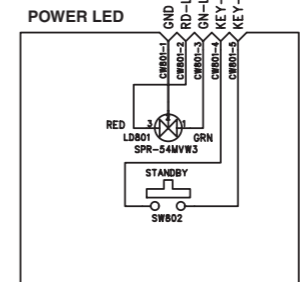

**SCHEMATIC DIAGRAM  
FRONT**

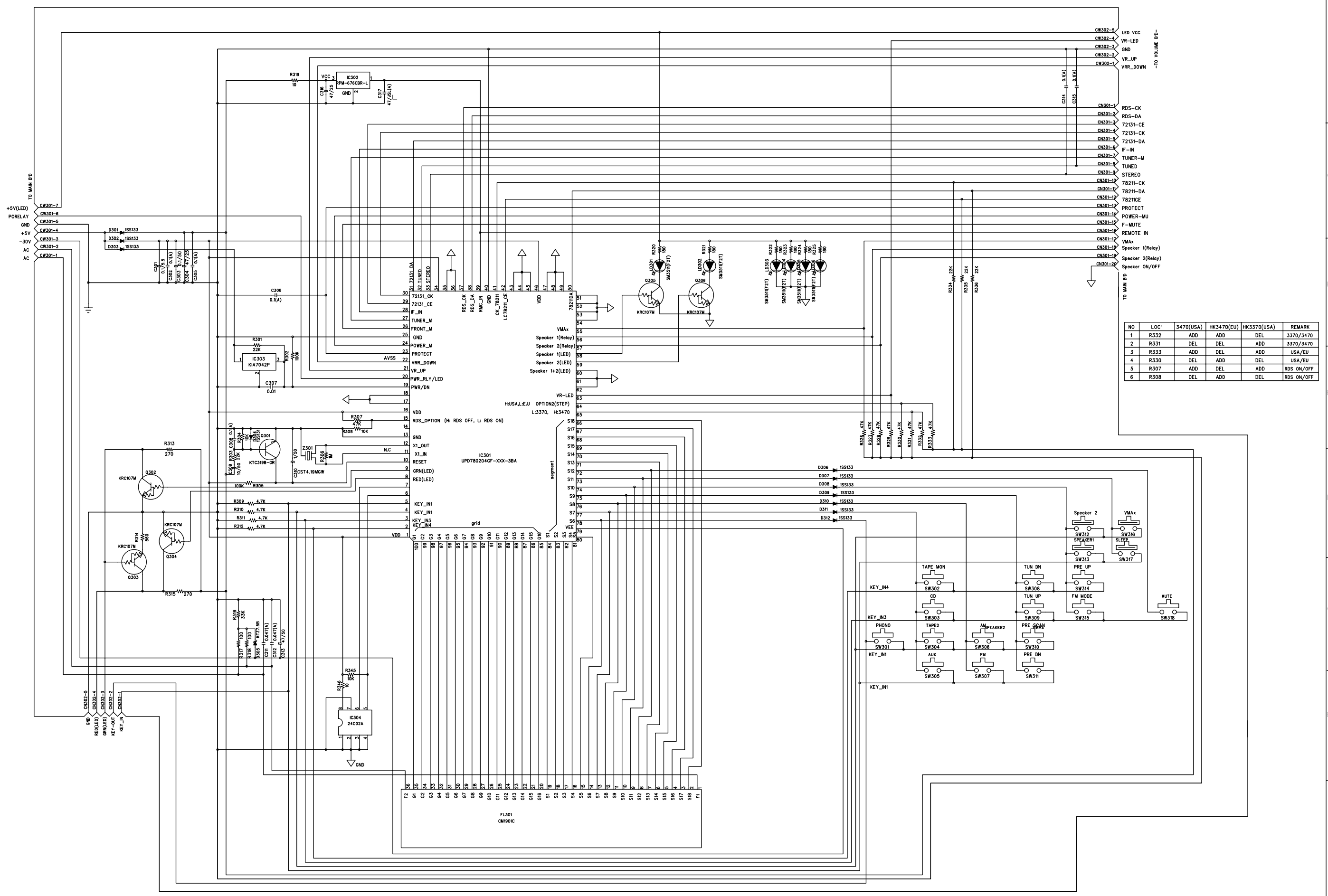

NO	LOC'	3470(USA)	HK3470(EU)	HK3370(USA)	REMARK
1	R332	ADD	DEL	ADD	3370/3470
2	R331	DEL	DEL	ADD	3370/3470
3	R333	ADD	DEL	ADD	USA/EU
4	R330	DEL	ADD	DEL	USA/EU
5	R307	ADD	DEL	ADD	RDS ON/OFF
6	R308	DEL	ADD	DEL	RDS ON/OFF

# SCHEMATIC DIAGRAM FRONT

## HK3370 / HK3470

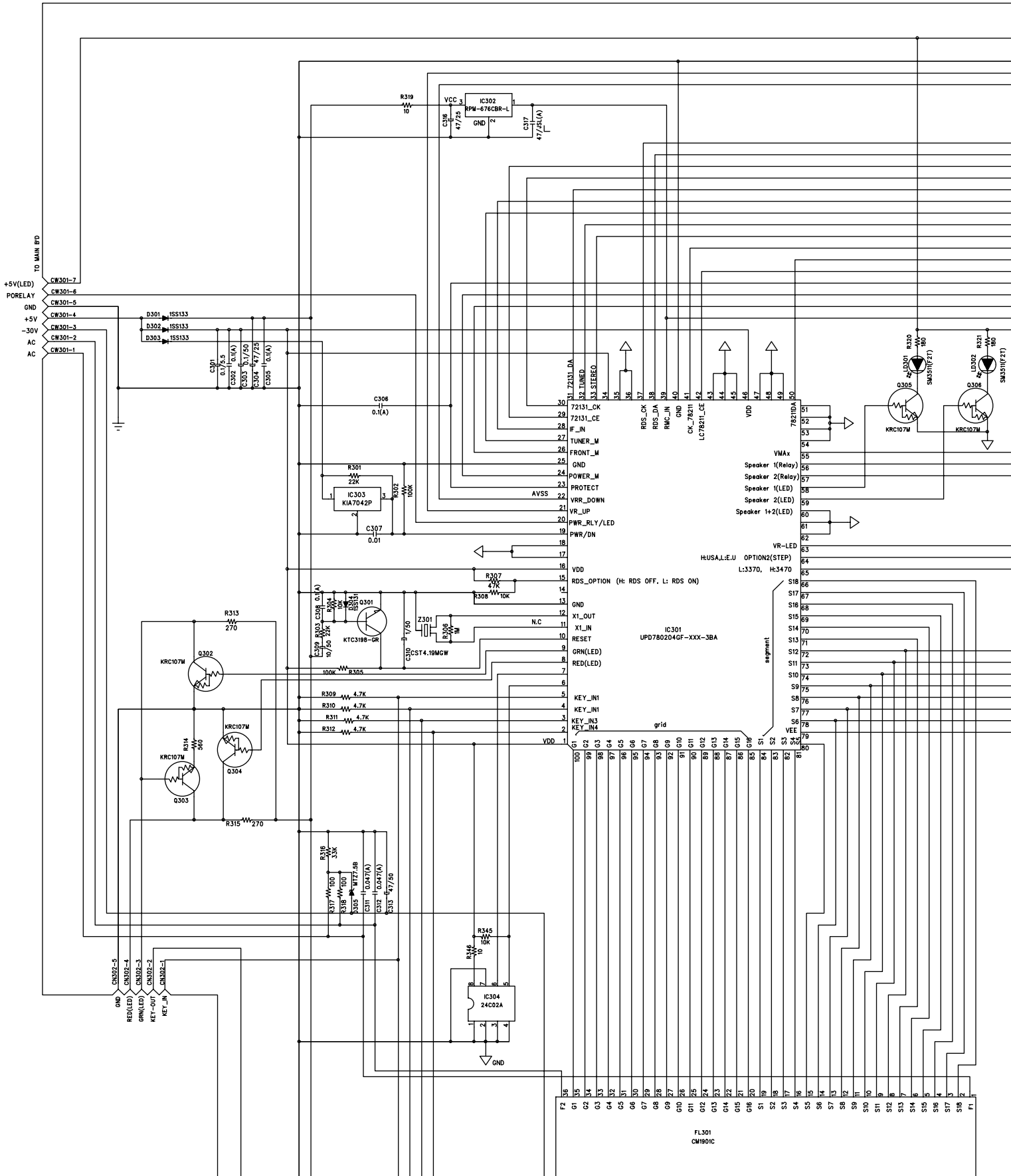

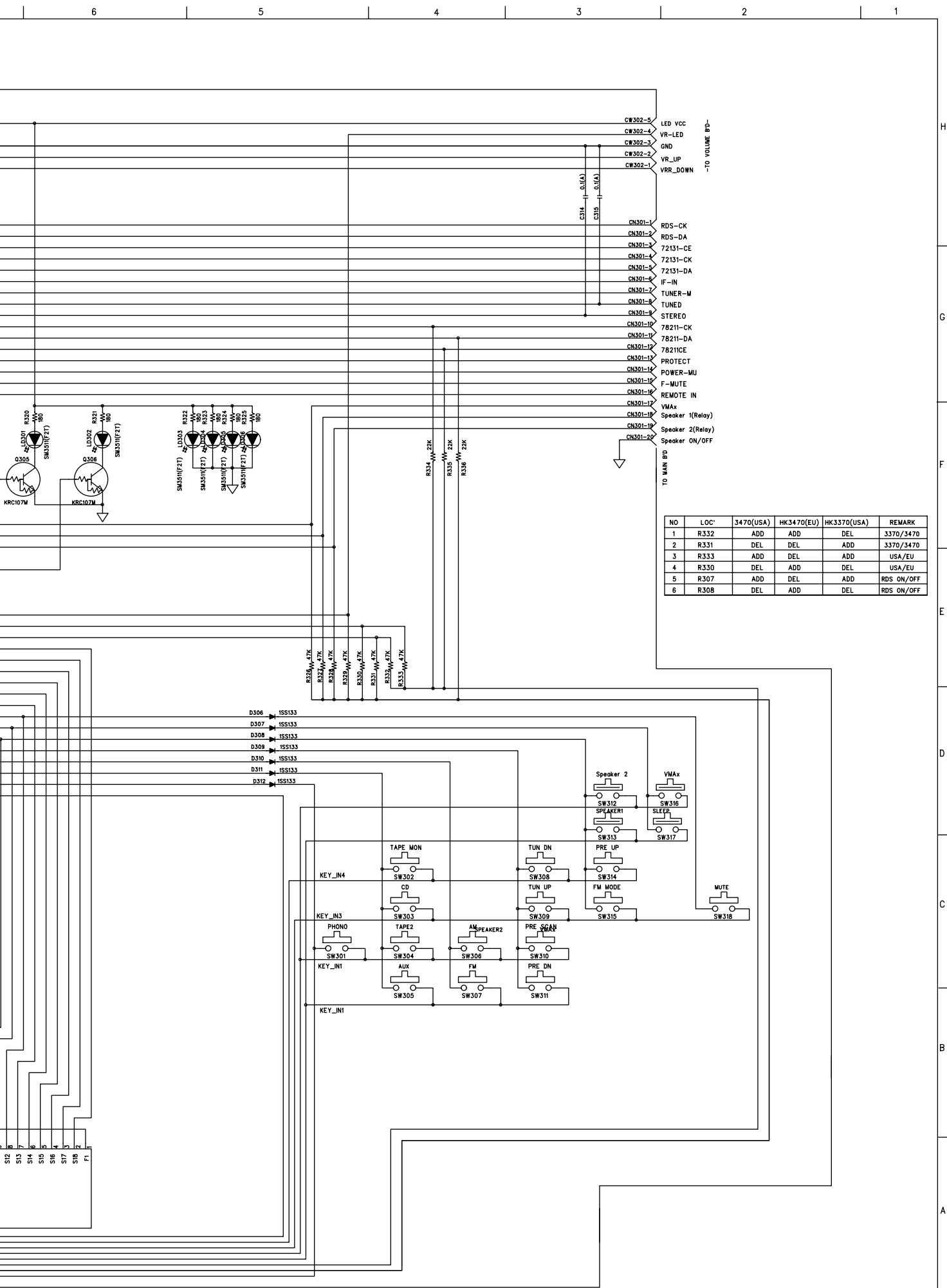

NO	LOC'	3470(USA)	HK3470(EU)	HK3370(USA)	REMARK
1	R332	ADD	ADD	DEL	3370/3470
2	R331	DEL	DEL	ADD	3370/3470
3	R333	ADD	DEL	ADD	USA/EU
4	R330	DEL	ADD	DEL	USA/EU
5	R307	ADD	DEL	ADD	RDS ON/OFF
6	R308	DEL	ADD	DEL	RDS ON/OFF

SCHEMATIC DIAGRAM  
TUNER/VR/HP

TUNER

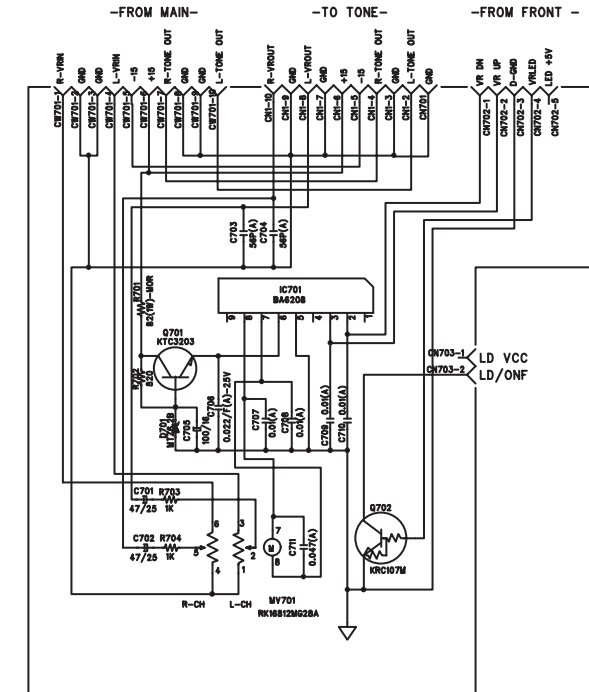
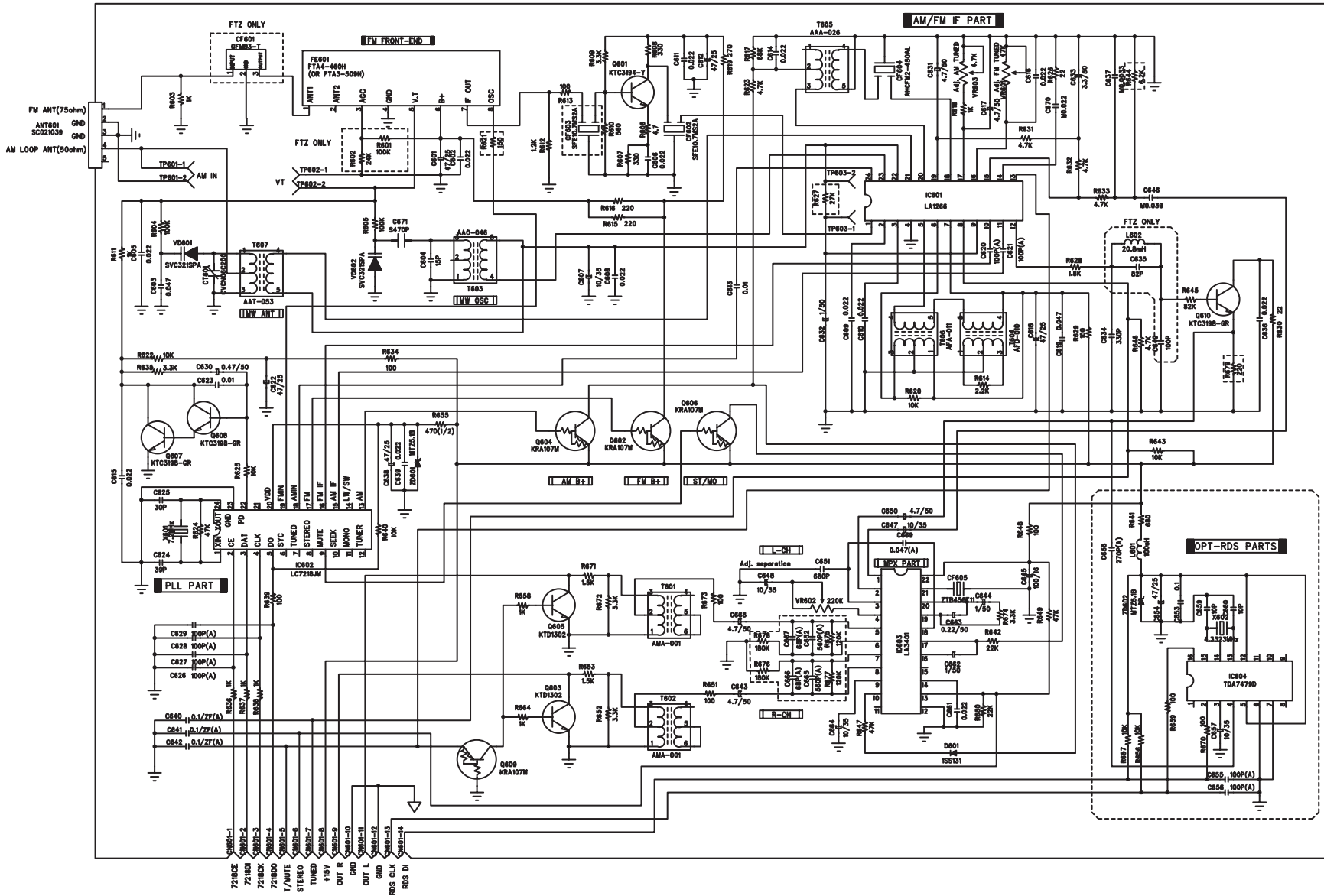

LOC NO	USA	EU
ANT801	SC0210	SC0210
CF601	X	O
JW16	O	X
FE601	FTA3-509HA	FTA4-460H
JW17	O	X
R602	X	O
R601		
C635	X	O
C649		
R644	6.2K	1.5K
L602	X	O
JW1	O	X
R675	120K	220K
R677		
C652	560P(A)	220P(A)
C665		
C666	68P(A)	10P(A)
R676	180K	270K
R678		
R627	27K	47K
R621	470	150
CF603	SFE 10.7MS2A	SFE 10.7MJA
RDS	X	O

HEAD PHONE

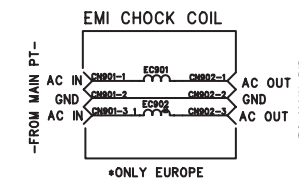
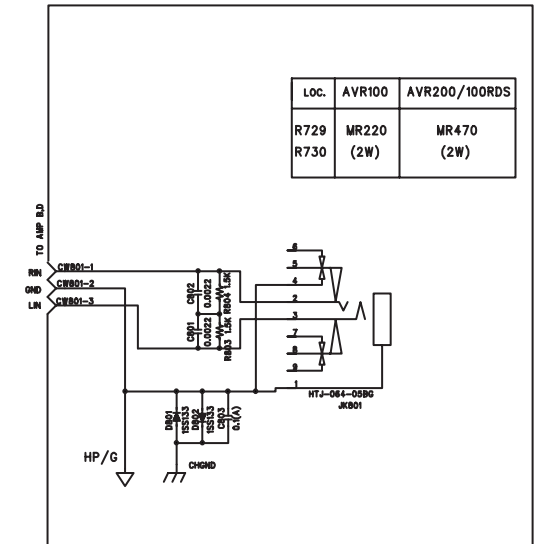



# 12. WIRING DIAGRAM

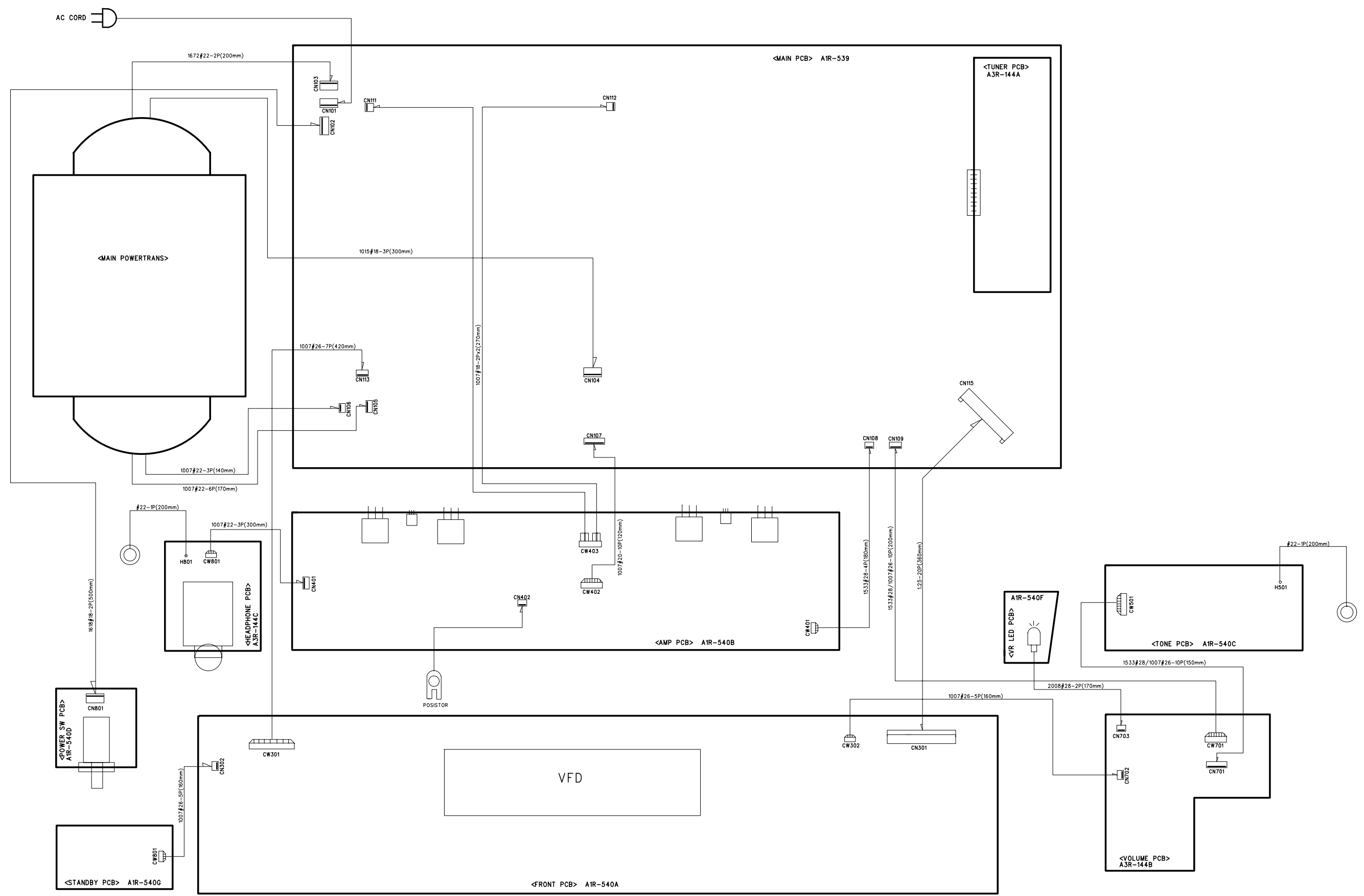

13. Packing Material

PACKING MATERIAL

HK-3370

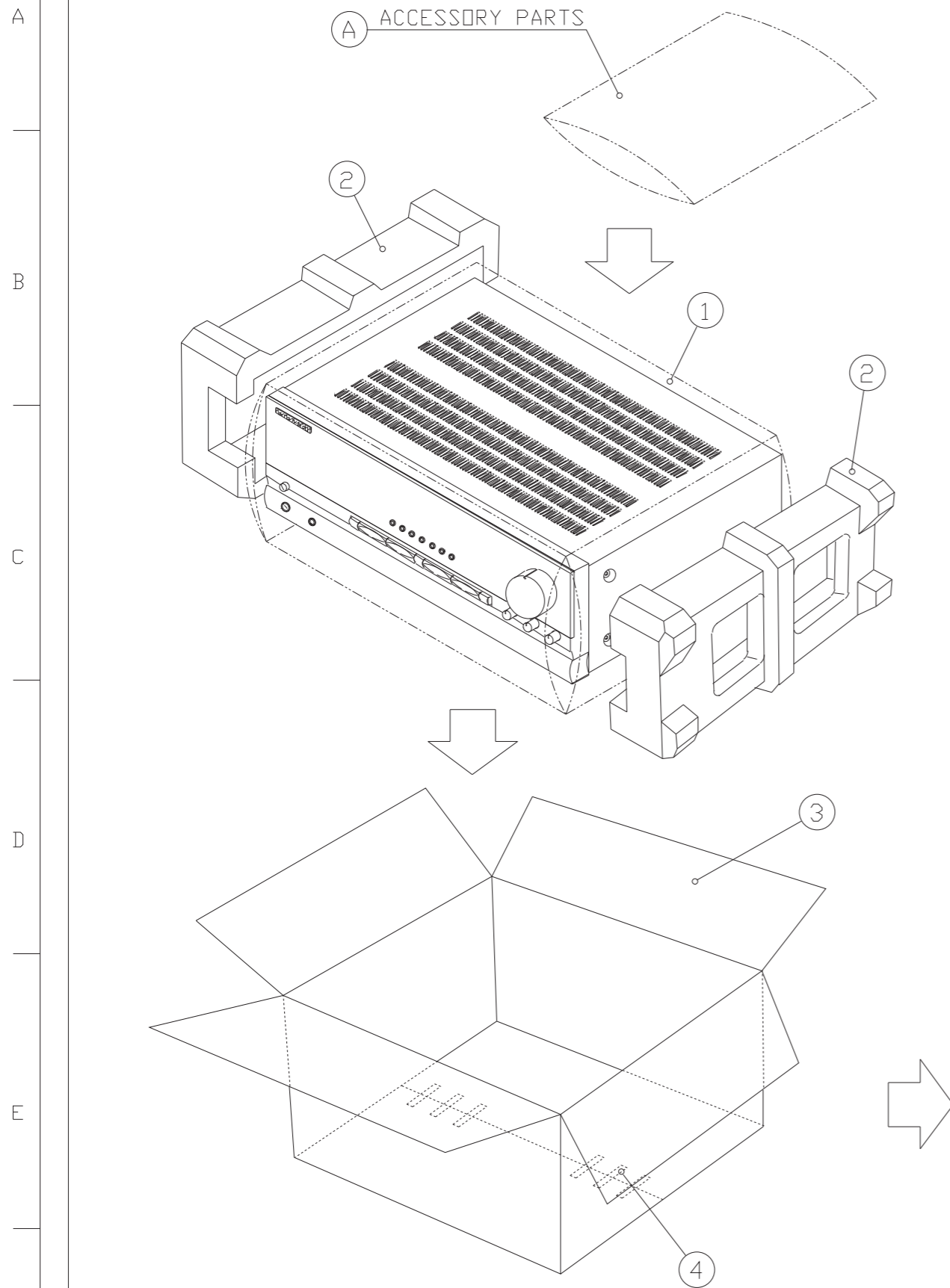

PACKING MATERIAL

HK-3370

NO	PARTS NAME	PART NO	Q'TY	REMARK
	POLY-BAG-I(G)	YVAP-01862-ZZ4	1	***
	INST-MANUAL	YIAR-K2001-02A	1	***
	REMOTE CONTROL ASS'y	ACRC-00670-000	1	***
A	WARRANTY CARD	YWAR-K2001-02A	1	***
	BATTERY MANGANESE	BAMN-00010-150	2	***
	ANTENNA-T TYPE	ANNT-00054-075	1	***
	ANTENNA-LOOP	ANL-00060-E50	1	***
	TRANSFORMER-MATCHING	TFMA-00100-D00	1	***
1	TOILON-SHEET	YVAP-13320-ZZ4	1	***
2	CUSHION-L/R	YSAP-12070-002	2	EPS
3	BOX-GIFT	YGAP-14860-ZZ4	1	DW2
4	AIR-STAPLES	MMSC-00900-004	6	STEEL
5	TAPE-OPP	ZTOP-00701-50C	*	***
6	PALLETS	MWAW-00910-003	*	***
7	WRAP	7JJG-00212-001	*	***
8	LABEL-CODE39	YBAP-15580-ZZ4	2	***
9	LABEL-UPC	YBAP-14930-ZZ4	2	***
10	LABEL-SERIAL NO	YBAP-14361-ZZ4	2	***

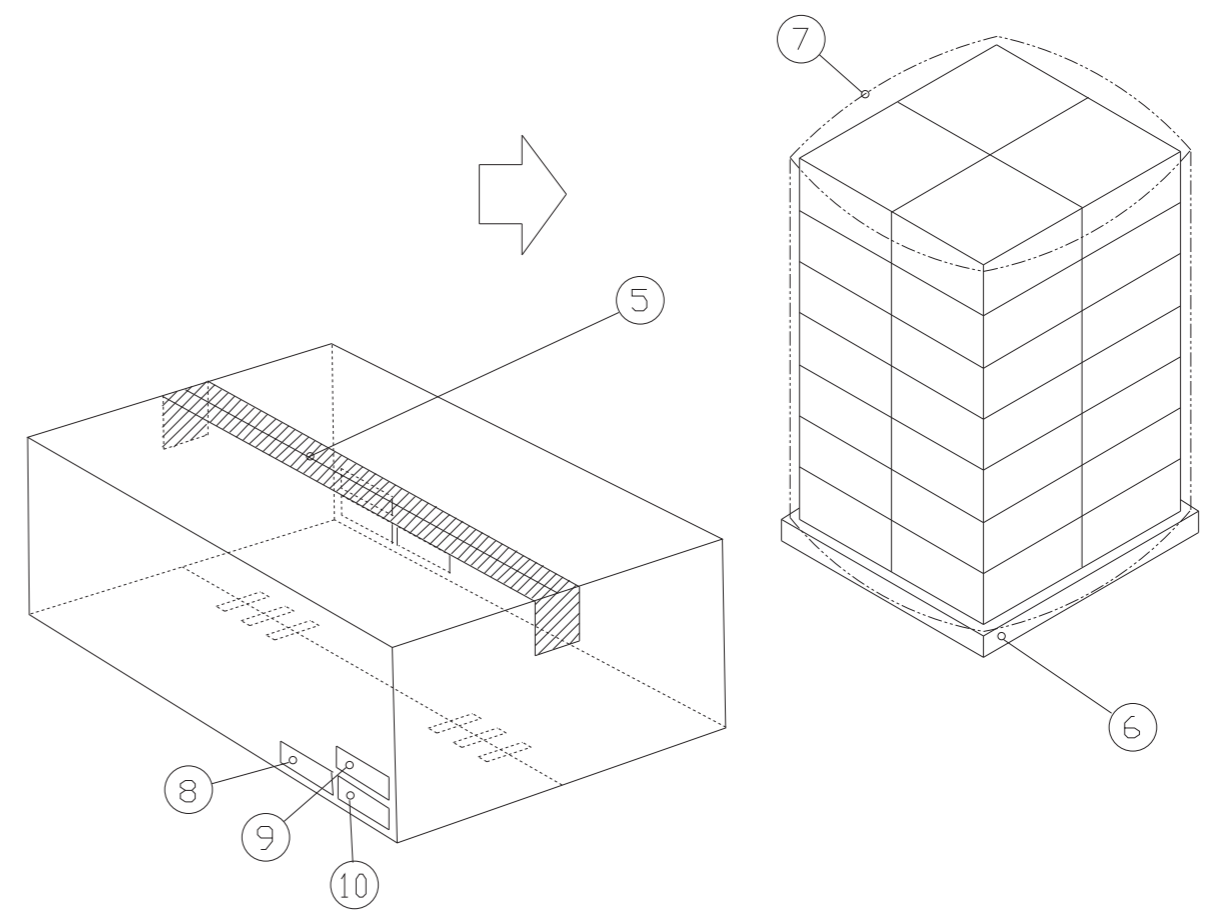

PACKING MATERIAL

HK-3470

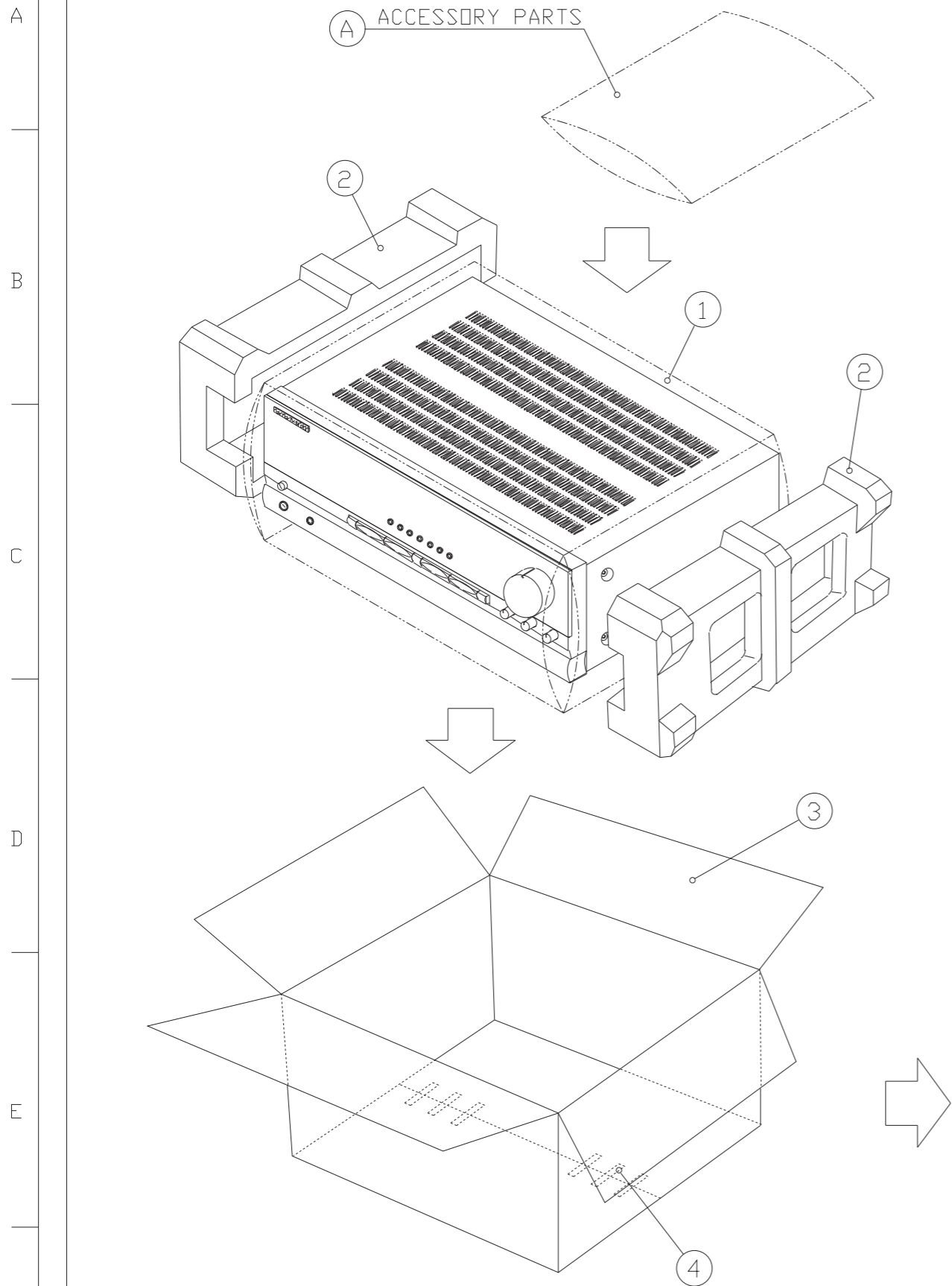

PACKING MATERIAL

HK-3470

NO	PARTS NAME	PART NO	Q'TY	REMARK
A	POLY-BAG-ICK	YVAP-01862-ZZ4	1	***
	INST-MANUAL	YIAR-K1001-02A	1	***
	REMOTE CONTROL ASS'y	ACRC-00680-000	1	***
	WARRANTY CARD	YWAR-K1001-02A	1	***
	BATTERY MANGANESE	BAMN-00010-150	2	***
	ANTENNA-T TYPE	ANNT-00054-075	1	***
	ANTENNA-LOOP	ANL-00060-E50	1	***
	TRANSFORMER-MATCHING	TFMA-00100-D00	1	***
1	TOILON-SHEET	YVAP-13320-ZZ4	1	***
2	CUSHION-L/R	YSAP-12070-002	2	EPS
3	BOX-GIFT	YGAP-14860-ZZ4	1	DW2
4	AIR-STAPLES	MMSC-00900-004	6	STEEL
5	TAPE-OPP	ZTOP-00701-50C	*	***
6	PALLETS	MWAW-00910-003	*	***
7	WRAP	7JJG-00212-001	*	***
8	LABEL-CODE39	YBAP-15580-ZZ4	2	***
9	LABEL-UPC	YBAP-14930-ZZ4	2	***
10	LABEL-SERIAL NO	YBAP-14361-ZZ4	2	***

